

# Tanktite™ (B-522-60-CS) Detachable Handle for Railcars

September 1, 2015  
(Rev 0)

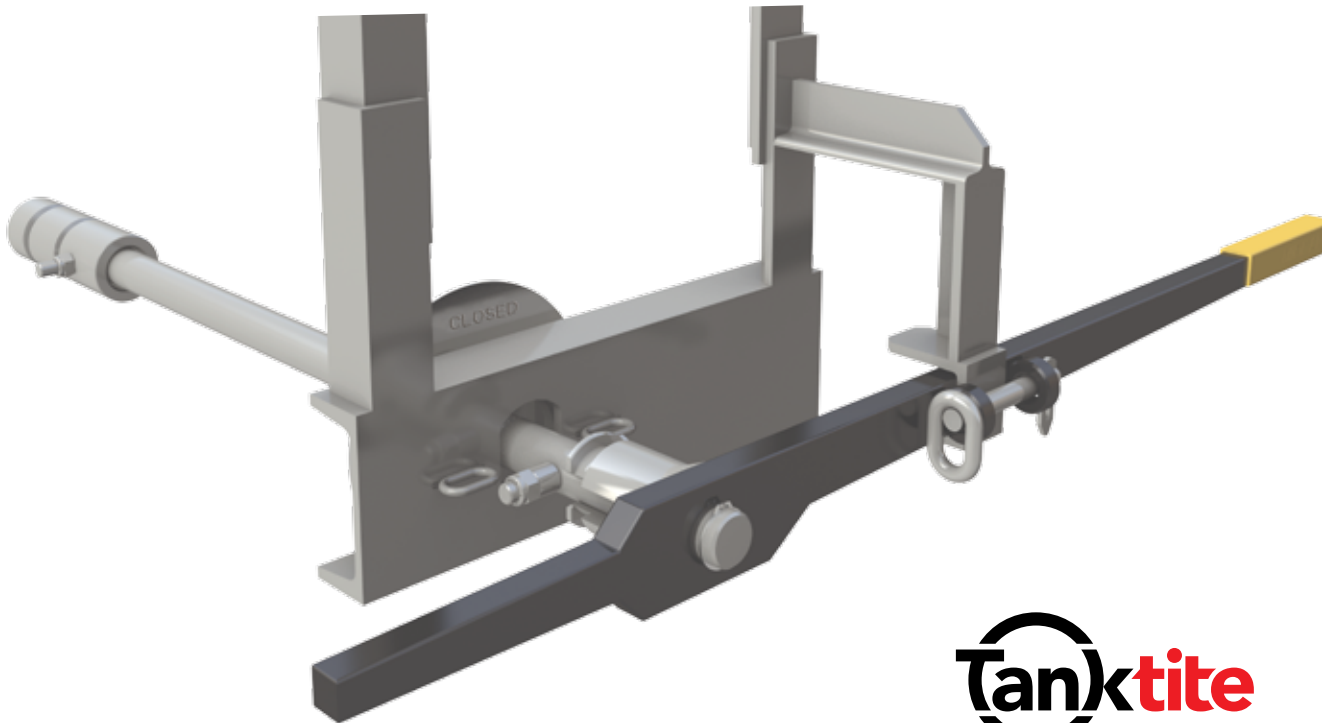

## TECHNICAL SPECIFICATIONS

- Meets AAR M-1002 Specifications – Tank Car Design Details, Appendix E Section 10.1.2.8 Bottom Outlet Actuation (September 2014 update)
- Couples with Midland A-520/522 Ball Valves
- Handle positively couples with valve when opened until fully closed
- Fits existing or new car builds – integrated mechanism and supports are easily tailored to differing car dimensions
- Disengagement can only occur after closing the ball valve
- Coupling with Engineered Shear Groove
- Shaft and supports are cable-lock ready

# Tanktite™ (B-522-60-CS) Detachable Handle for Railcars

September 1, 2015  
(Rev 0)

NO.	PART NAME	PART NUMBER	QTY
1	BEARING, TEFLON	551-605-TF	1
2	BOLT, HANDLE BALL VALVE, 7/16-20 UNC-2A, 3" LONG	520-172-CS	3
3	MAIN BRACKET ASSEMBLY	522-60617-CS	1
4	BUSHING	522-60602-CS	2
5	COUPLING	520-18-CS	1
6	EXTENSION SHAFT	522-60604-SS	1
7	HANDLE ASSEMBLY, WELDMENT	522-60606-CS <sup>3</sup>	1
8	LOCK WASHER	520-161-CS	1
9	NYLON INSERT, LOCKNUT, 7/16-20 UNF-2B	520-162-CS	2
10	RETAINING RING	549-604-SS	1
11	PACKING WASHER	551-604-CS	2
12	INDICATOR	522-60615-CS	1
13	BOLT, 1/4-20 UNC-2A, 2" LONG	522-60616-CS	1
14	ANGLE BRACKET	522-60618-CS	2
15	NYLON INSERT, LOCKNUT, 1/4-20 UNC-2B	522-60619-CS	1
16	EXTERNAL RETAINING RING, SST, 1-1/8" DIA.	522-60605-SS	1
17	HANDLE GRIP	549-72	1
18	PAD	522-60620-CS <sup>4</sup>	2

**Notes:**

1. Critical surface on shaft, protect it from paint and weld splatters
2. To operate A-520/A-522 Ball Valves
3. Painted by Midland
4. Optional; not furnished unless requested

