



Rupture Disc Devices

Operation Inspection and Maintenance



ITEM No.	PART NAME
1	Top
2	Base
3	Disc
4	Retainer
5	Swing Pin
6	Nut
7	Stud
8	Hinge Pin
9	Eye Bolt Pin
10	Chain
11	Cotter Pin
12	Eye Bolt
13	Wire Seal

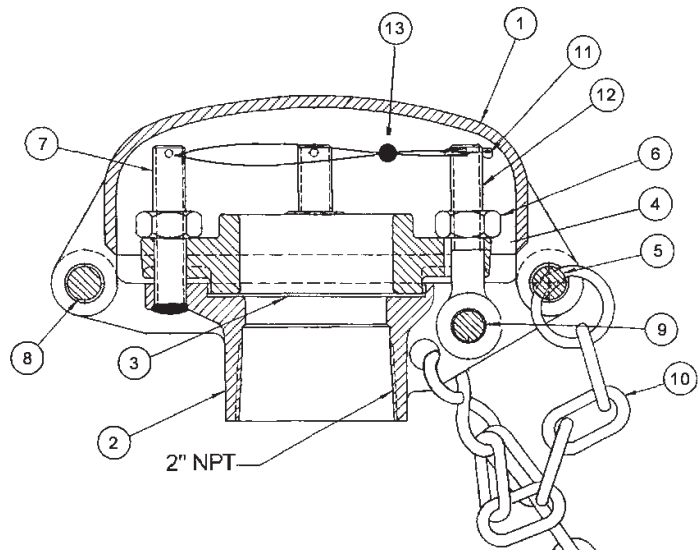

CAUTION: IMPORTANT SAFEGUARDS

Midland rupture disc devices are used in connection with a variety of products, many of which are hazardous materials and could cause serious injury or damage.

Always use extreme caution and proper equipment when involved with hazardous materials.

This device should only be handled by qualified personnel.

Read all of these Instructions carefully before proceeding.

SAVE THESE INSTRUCTIONS!

Operation

A rupture disc device (RDD) is a non-reclosing pressure relieving device. The pressure-containing element is a rupture disc, which when new is carefully tested in accordance with AAR Appendix A, paragraph A5.03. It is actuated by a pressure buildup inside the tank, due either to substantial heat input into the tank, or pressure spikes generated by surging liquid in the tank. It is advisable for all personnel to stay away from the device, unless inspection and maintenance on it is to be performed.

Inspection and Maintenance



WARNING: Exercise extreme caution when inspecting the RDD and/or its disc if there is any pressure in the tank. Even though there may be only a nominal amount of pressure in the tank, the disc may be weakened or cracked. If there is a hard-plastic disc in the RDD, it may shatter explosively. Do not stand directly over the RDD. Be prepared with the proper protective equipment in the event there is an unanticipated product emission through the RDD.

1. To inspect the rupture disc, all Midland RDDs have a patented inspection capability. Pull out the swing pin (part number 5).
2. Open the top (part number 1). It is hinged on the hinge pin (part number 8).
3. Inspect the disc for any evidence of malfunctioning. Frequently, a crack in the disc (part number 3) or the presence of product residue in the center opening of the retainer (part number 4) will indicate that the disc must be replaced.
4. If you decide to change the disc, be prepared for product to be released through the RDD. Wear suitable protective clothing. Stand upwind of the RDD. Another person should be present to go for assistance if additional help is unexpectedly required.
5. So that you won't be taken by surprise, crack open an air vent valve to check to see if there is pressure in the tank. If pressure escapes, you know there is pressure in the tank. If no pressure escapes from the vent valve, there still is no assurance that there is no pressure in the tank as the air valve may be plugged with product. Always be prepared for the worst conditions and take all necessary precautions.
6. Have available a replacement disc and disc gasket.
7. The four 1/2" heavy hex nuts require a 7/8" open-end crescent wrench. Also, have a wire brush and a screwdriver available.
8. Back off all four 1/2" nuts up to the cotter pins. The cotter pins are positioned to prevent the nuts from being taken completely off the studs, and possibly lost.
9. The eyebolt (part number 12) is hinged to rotate outward. Swing it forward as far as it will go.
10. Pick up the retainer. If it is stuck, use the screwdriver to pry it up.
11. Take out the old disc. It may be necessary to again use the screwdriver to dislodge it. Be careful when using the screwdriver not to gouge into the surface the disc sits on. This could result in a leak path around the disc. Discard the old disc.
12. Clean out the recess in the valve base (part number 2) where the disc was located. Use a wire brush to dislodge solidified product. Use a clean cloth to wipe away the debris. Inspect the surface to see that it is free of defects that would cause a leak around the disc to take place.
13. For composite discs (a sandwich of three layers of materials) use a thin PTFE gasket into the body recess. Softer metals, like

aluminum and lead, will serve as gaskets, so no PTFE gasket is required.

14. Put the disc in the recess and reposition the retainer (the 3-1/8" diameter surface faces downward) and swing the eyebolt to the vertical position.
15. If there is any pressure in the tank, it will try to dislodge the disc as you tighten down on the four nuts. Keep the disc centered in the recess with a finger pressing lightly down on it. Alternately tighten down on the nuts – 1 and 3, then 2 and 4 – to a torque of 30 ft-lb.
16. Since it may not be possible to get a pressure test for leakage with the RDD assembly mounted on the tank, close the hinged cover and insert the swing pin.
17. If the RDD is being bench tested, and a new disc has been installed into the vent, it is possible to check around the disc for leaks. In this case, bring the pressure in the test chamber up slowly. **Do not permit the pressure to exceed 60% of the disc's rated rupture pressure**, or the disc may sustain damage by exceeding the yield strength of the material.
18. Use soap suds around the retainer and in the central cavity above the disc for evidence of leakage.
19. If there is leakage between the disc and its seat, disassemble the RDD (following steps 8 through 12) and reclean the recess in the body. A new disc or gasket may be required. After reassembly, if the device still leaks, do not send it out to have the seat refaced. Consult Midland about the proper remedial steps.
20. If no leaks are apparent, relieve the pressure in the test chamber and unmount the RDD.
21. Drain whatever water may have accumulated and wipe or blow away with an air hose any soap suds and water remaining after the test.
22. Put an appropriate preservative or paint on the exterior surfaces of the RDD. Store in a dry place until ready to use.

NOTICES AND WARRANTY

Regulations

Midland Rupture Disc Devices are used in a variety of products, many of which are hazardous materials. The acceptance and transportation of the products are regulated by the DOT and AAR in the U.S.A., and in Canada by the CTC and Transport Canada, as well as other governmental bodies, particularly when used in stationary applications. All personnel should be familiar with and follow these regulations. Nothing in this pamphlet is intended to conflict with or supersede these regulations.

The information in this document was gathered from knowledgeable sources, but Midland Manufacturing Corporation makes no representations or guarantees about its accuracy or completeness and assumes no liability for this information. Specifications are subject to change without notice.

Obtaining Product Drawings

Assembly drawings of Midland Rupture Disc Devices are available at no charge, and will be mailed upon request. Address any questions concerning valve maintenance or usage to the Engineering Dept., Midland Manufacturing Corp.

Warranty

Midland warrants the products of its own manufacture to be free of defects in material and workmanship, under normal use and proper operation, for a period of one (1) year from the date of invoice. Furnished materials and accessories purchased from other manufacturers are warranted only by and to the extent of those manufacturers' warranties, if any.

MIDLAND MAKES NO WARRANTY OF ANY KIND WHATSOEVER, EXPRESS OR IMPLIED, OTHER THAN AS SPECIFICALLY STATED HERE. MIDLAND MAKES NO WARRANTIES OF MERCHANTABILITY OR FITNESS FOR ANY PARTICULAR PURPOSE OR USE. Midland's obligation under this warranty is strictly limited, at its option, to 1) repair or replacement at its factory of a like quantity of product: 2) refunding to purchaser money paid to Midland for its product: or 3) issuance of written authorization for the Purchaser to repair or replace, at costs comparable to Midland's normal manufacturing costs those parts proven defective, provided that Purchaser has given to Midland immediate notice upon discovery of such defect. Merchandise claimed to be defective shall not be returned without first obtaining Midland's written consent. The undertaking of repair or replacement by the Purchaser, or its agents, without Midland's written consent, shall void Midland's warranty and relieve Midland of all responsibility. Under no circumstances shall Midland be liable for any direct, incidental, consequential or other damages of any kind in connection with the installation, operation, maintenance, repair, inspection or other use of any product purchased from it.



A **DOVER** RESOURCES COMPANY

Mail to: P.O. Box 226, Skokie, IL 60076-0226
7733 Gross Point Road, Skokie, IL 60076-0226
Phone: (847)677-0333, Fax: (847)677-0138