

# IMPORTANT INFORMATION

## FOLLOW ALL INSTRUCTIONS

**NOTICE: OPW-FCS system components may only be installed and serviced by a factory trained and currently certified installer in order for the product warranty to be valid. The use of non-certified personnel or any deviations from these written procedures could result in damage or leakage of the system and void the product warranty. Contact OPW-FCS's Customer Service Department for more information at 1-800-422-2525.**

Please read these warnings and use and assembly instructions completely and carefully before starting. Failure to do so may cause product failure, or result in environmental contamination due to liquid leakage into the soil, creating hazardous spill conditions.

### OPW STANDARD PRODUCT WARRANTIES

FLEXWORKS™ by OPW, Inc., VAPORSAVER™ and all other OPW products must be used in compliance with all applicable federal, state, provincial and local laws, rules and regulations. Product selection must be based on physical specifications and limitations, compatibility with the environment and material to be handled. All illustrations and specifications in the literature are based on the latest production information available at the time of publication. Prices, materials and specifications are subject to change at any time, and models may be discontinued at any time, in either case, without notice or obligation.

OPW warrants solely to its customer that the following products sold by OPW will be free from defects in materials and workmanship under normal use and conditions for the periods indicated:

Product	Warranty Period
FlexWorks Primary Pipe	10 years from date of manufacture
All Products Certified to California Standards *	1 year from date of manufacture or from date of installation registration (not to exceed 15 months from date of manufacture)
All other Products	1 year from date of manufacture

\* Products certified to California 2001 Standards will have an OPW Registration Card enclosed/attached to the product.

OPW's exclusive obligation under this limited warranty is, at its option, to repair, replace or issue credit (in an amount not to exceed the list price for any defective product) for future orders for any product that may prove defective within the applicable warranty period (repairs or replacements are subject to prorated warranty coverage for remainder of the original warranty period). Complete and proper warranty claim documentation and proof of purchase required. All warranty claims must be made in writing and delivered during the applicable warranty period to OPW at 9393 Princeton Glendale Rd., Hamilton, Ohio 45011, Attention: Customer Service. No products may be returned to OPW without its prior written authority.

This limited warranty shall not apply to any FLEXWORKS™ or VAPORSAVER™ product unless it is installed by an OPW attested installer. This limited warranty also shall not apply to any FLEXWORKS™, VAPORSAVER™ or other OPW product: unless all required site and warranty registration forms are completed and received by OPW within 60 days of installation; unless all piping connections are installed with a nationally-recognized or state-approved leak detection device in each tank and dispenser sump (which are not for storage and from which all discharge hydrocarbons must be removed, and the systems completely cleaned, within 24 hours); unless testable sumps utilize FLEXWORKS™ pipe and access fittings; unless a sump inspection log or an EPA recommended/required checklist is maintained and the results are furnished to OPW upon request; and unless OPW is notified within 24 hours of any known or suspected product failure and is provided with unrestricted access to the product and the site. This limited warranty also shall not apply to any product which has been altered in any way, which has been repaired by anyone other than a service representative authorized by OPW, or when failure or defect is due to: improper installation or maintenance (including, without limitation, failure to follow all FlexWorks™ Installation Manuals and Installation Guides and all product warning labels); abuse or misuse; violation of health or safety requirements; use of another manufacturer's, or otherwise unauthorized, substances or components; soil or other surface or subsurface conditions; or fire, flood, storm, lightning, earthquake, accident or any other conditions, events or circumstances beyond OPW's control.

THIS LIMITED WARRANTY IS IN LIEU OF ALL OTHER WARRANTIES, EXPRESS OR IMPLIED, AND ALL OTHER WARRANTIES INCLUDING, WITHOUT LIMITATION,

TATION, THE WARRANTIES OF MERCHANTABILITY AND FITNESS FOR A PARTICULAR PURPOSE, ARE HEREBY EXCLUDED. OPW shall have no other liability whatsoever, whether based on breach of contract, negligence, gross negligence, strict liability or any other claim, including, without limitation, for special, incidental, consequential or exemplary damages or for the cost of labor, freight, excavation, clean-up, downtime, removal, loss of profit, or any other cost or charges. No person or entity is authorized to assume on behalf of OPW any liability beyond this limited warranty. This limited warranty is not assignable.

**NOTE:** FlexWorks™ piping systems should be installed by OPW trained and certified personnel and the use of non-qualified personnel or any deviations from these recommended procedures could result in damage or leakage of the system.



**WARNING**

**FAILURE TO COMPLY WITH THE FOLLOWING WARNING COULD RESULT IN PROPERTY DAMAGE, INJURY OR DEATH.**



**WARNING**

**FIRE AND EXPLOSION HAZARD**

Using electrically operated equipment near gasoline or gasoline vapors may result in a fire or explosion, causing personal injury and property damage. Be sure that the working area is free from such hazards, and always use proper precautions.

FlexWorks™ piping systems are for use as underground piping for primary carrier and secondary containment for motor vehicle fuels, aviation, and marine fuels.

**NOTE:** Failure to secure written approval from OPW concerning non-warranted fuels and liquid chemicals, will void the product warranty and could potentially cause environmental damage or personal injury.

**Installation Tools Required:**

- Drill with 5/16" drill bit.
- Hole saw (See Step #2)
- Strap Wrench or Smooth Jaw Wrench (Note: Do not use wrench with teeth)
- Drill
- Torque Wrench

- 7/16" Socket
- 9/32" or 7mm Socket

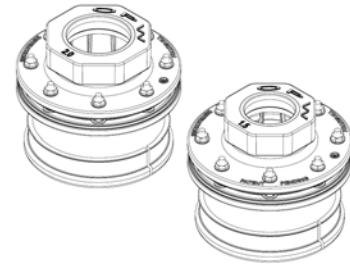

**Only use BMA-1515, BMA-2020, DPC-2150A, DPC-2200A, SPC-0150A, SPC-0200A, SBC-2150 and SBC-2200 couplings and FlexWorks Double Wall pipe with REF-4015 and REF-4020 Rigid Entry Fittings. REF-0075C is for use with 3/4" Rigid Conduit and REF-0100C is for use with 1" Rigid Conduit.**

**Rigid Entry Fittings**

Rigid Entry Fittings are designed to seal pipe entries through containment sump and AST walls. For proper installation, a template (supplied with fitting) must be used for accurate hole drilling. **Rigid fittings cannot be installed on round surfaces.**

**Step #1 (See Figure 1)**

Locate and mark the center of the pipe entry point in the flat wall section of the sump. Drill a 5/16" hole in each

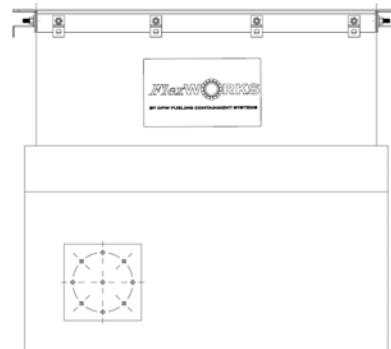

**Figure 1**

location. Once the holes are drilled remove the template from the sump and proceed to step number 2.

**Step #2 (See Figure 2, and Figure 2A)**

Drill out the entry fitting opening with the appropriate size hole saw using the center hole as a guide. Clean any rough edges.

**Hole Saw**

- 4"
- 4"
- 4"
- 2-1/2"

**Entry Fitting**

- REF-4015 / REF-4015A
- REF-4020 / REF-4020A
- REF-0200F
- REF-0075C / REF-0100C

**IMPORTANT:** The correct hole saw size must always be used for proper installation of Entry Fittings.

**NOTE:** Only use hole saws that are sharp and in good condition. Use caution to prevent injury. The hole saw may catch unexpectedly and rotate drill.

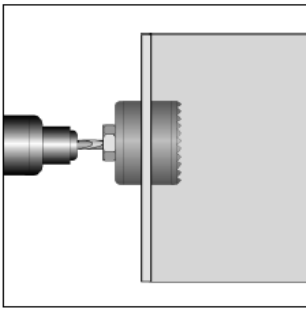

Figure 2

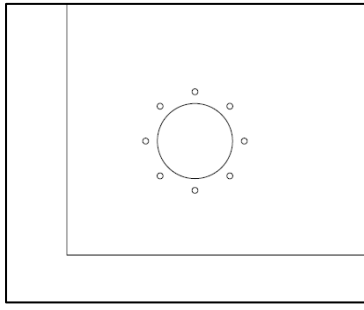

Figure 2A

**Step #3 (See Figure 3)**

Install the gasket on the body and place through the holes in the sump. Once through, install the interior gasket over studs.

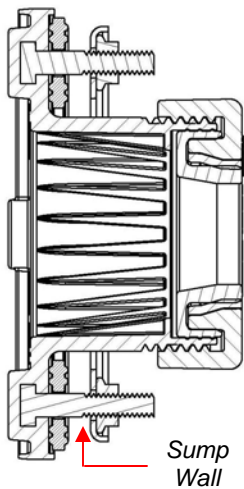
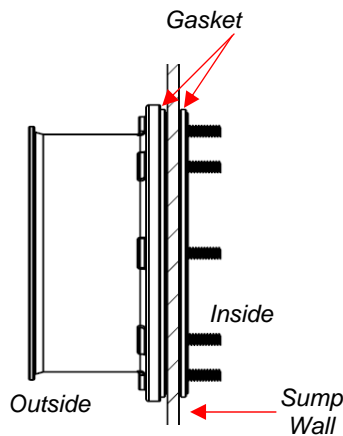

Figure 3



**Step #4 (See Figure 4 and 4A)**

Install the interior boot half over the studs with the raised threaded portion facing away from the sump wall and install the nuts by hand. Using a torque wrench, tighten each bolt, in increments, to 60 in-lb using a star pattern as illustrated below. Tighten 3/4" and 1" fittings in a criss-cross pattern evenly.

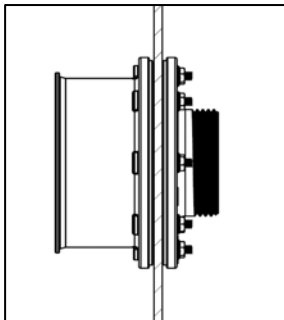

Figure 4

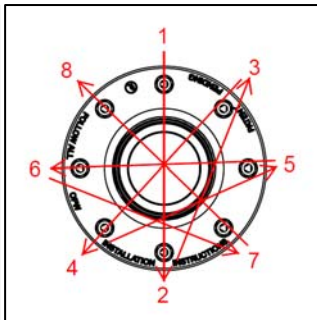

Figure 4A

**Entry Fitting Sealants**

OPW-FCS does not recommend the use of sealants when installing entry fittings on poly sumps, however, the proper

application of approved sealants on the sealing surface of our entry fittings is acceptable to OPW-FCS.

The sealant(s) must be compatible with all contacted entry fitting materials, all ground environments and any fuels that may be secondarily contained within the sumps being sealed. OPW-FCS in no way warrants the performance of the sealant and is in no way responsible for any environmental release resulting from the use of said sealant(s). All entry fittings must be installed in accordance with OPW-FCS's written installation instructions by a currently certified installer.

If you choose to use a sealant, OPWFCS recommends the following sealants for use with our entry fittings and sumps: **Bostik 920 FS Fast Set, marine grade urethane sealant; SL -1100 Urethane Sealant; Thiokol 1100 Industrial polysulfide joint sealant or PR 1440 Class B Fuel Tank sealant.**

**Note: Be sure all manufacturers' installation and application instructions are followed.**

**Step #5 (See Figure 5)**

Lubricate all surfaces of the seal with OPW approved lubricants (See Appendix A). Insert pipe through the center of the fitting and slide the seal and nut over the pipe before making the connection to the tee or elbow. **Note: Make sure the flat end of the seal is facing the sump wall.**

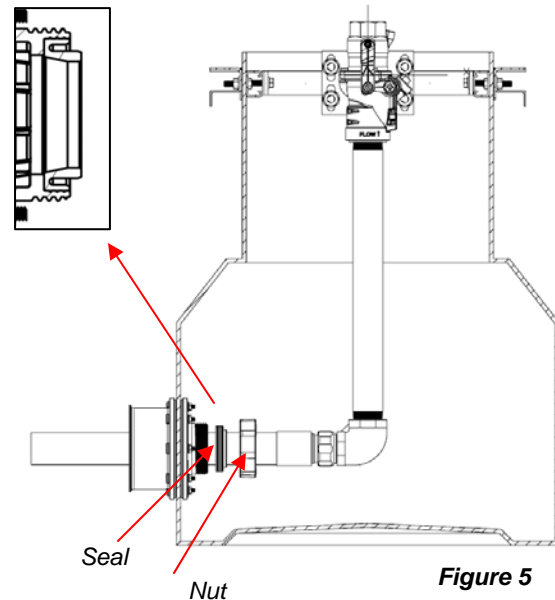

Figure 5

**Step #6 (See Figure 6 and Figure 6A)**

Make the pipe connection. Insert the seal inside the body of the fitting. Tighten the nut with a strap wrench until the end of the seal is flush with the face of the nut or approximately 3 and 1/2 turns.

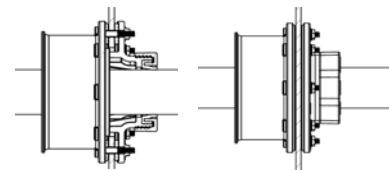

Figure 6

Figure 6A

**NOTE: Conduit Fittings have text on the face of the seal for ease of identification.**

**Note:** 3/4" must have adaptor installed in proper orientation

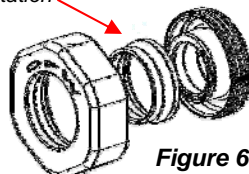

Figure 6B



Figure 6C

**NOTE: FOR REF-4015 AND REF-4020 ONLY:**

**Step #7 (See Figure 7, Figure 7A and Figure 7B)**

Cut the AXP Piping between two ribs then install two seals on the two end grooves of the AXP piping as shown. Lubricate the interior surface (See Step 5) of the fitting, then insert the AXP piping into the body.

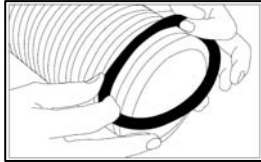

Figure 7

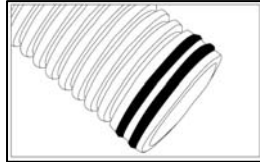

Figure 7A

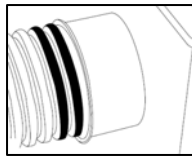

Figure 7B

*Note: Crush protector is built into the fitting.*

**Step #8 (See Figure 8 and Figure 8A)**

Install the AXP clamshell around the fitting and the AXP piping. Install the band clamp to 30—35 in-lbs.

**Note:** Per California SB-989, all metal must be protected from direct contact with the elements. Coat stainless steel band clamps with the following approved coatings: OPW SL-1100, 3M Underseal 08883 or Polyguard Mastic CA-9.

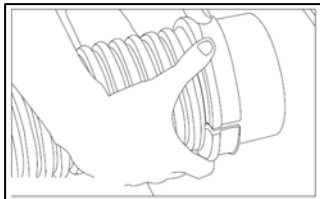

Figure 8

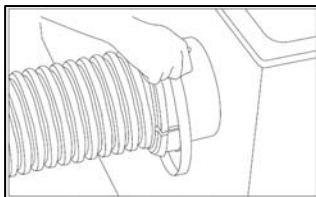
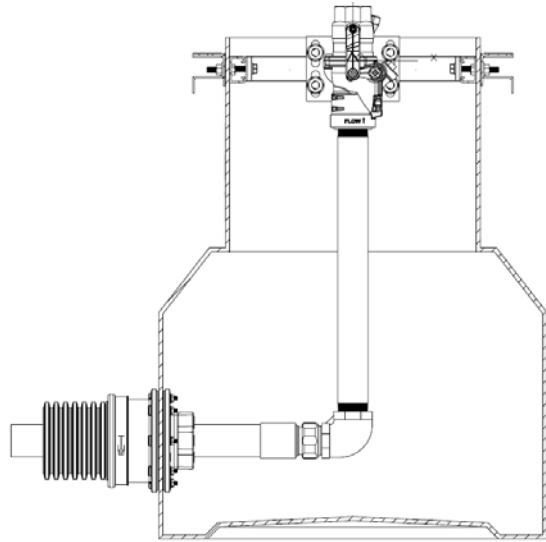

Figure 8A

**Reference Illustration of Installation:**



**Angled Entries**

The entry fitting is flexible enough to permit angled pipe or conduit entries up to 5 degrees in each direction.

**Round Surface Installations**

Rigid Entry Fittings **CANNOT** be installed on round surfaces.

**NOTE:** Keep fiberglass cleaning solvents away from the entry fittings to prevent damage.

**APPENDIX A**

**OPW APPROVED LUBRICANTS**

**NOTE:** Always read MSDS sheets carefully before using any chemical.

- ◆ Parker O-Lube
- ◆ Black Moly Grease
- ◆ Ru Glyde Rubber Lubricant
- ◆ Super Lube Synthetic Grease



**OPW Fueling Containment Systems**  
3250 US 70 Business West  
Smithfield, NC 27577  
Customer Service: 1-(800) 422-2525  
Technical Service and Questions:  
1-(877) OPW-TECH  
www.opwglobal.com



Notice: OPW-FCS products must be used in compliance with applicable federal, state, provincial and local laws and regulations. Product selection should be based on physical specifications and limitations and compatibility with the environment and material to be handled. OPW-FCS makes no warranty of fitness for a particular use. All illustrations and specifications in this literature are based on the latest production information available at the time of publication. Prices, materials and specifications are subject to change at any time, and models may be discontinued at any time, in either case, without notice or obligation. For complete OPW-FCS warranty information, visit our web site at [www.opwglobal.com](http://www.opwglobal.com).