

# Installation Instructions

## Wide Access Dispenser Sumps (DSW) Stabilizer Bar Kits (SBK)

**IMPORTANT:** Please read all warnings and follow the installation instructions completely and carefully. Failure to do so will void all warranties and may cause product failure, or result in environmental contamination due to liquid leakage into the soil, creating hazardous spill conditions.

**WARNING - DANGER:** Using electrically operated equipment near gasoline or gasoline vapors may result in fire or explosion, causing personal injury and property damage. Be sure that the working area is free from such hazards, and always use proper precautions.

### Dispenser Sumps

FlexWorks Dispenser Sumps are installed beneath fuel dispensers to provide access to and secondary containment of fuel dispensers and piping connections. FlexWorks Emergency Valve Stabilizer Bar Kits are required to install boss mounted emergency shut-off valves in FlexWorks Dispenser Sumps. Use only OPW Fueling Containment System supplied hardware and components.

### Mounting the Dispenser Sump in the Island Form

Dispenser sumps are typically mounted inside of permanent metal island forms. The sump must be mounted so that the top of the sump mounting frame is flush with the finished concrete surface of the island. The sump must be secured in the island form prior to backfilling and concrete pouring. Structural ribs formed into the sides and ends of the containment chamber can be used to mount the sump in the island form. The sump can be supported by resting a sump rib on top of permanent support bars inside the island form.

### Step #1 (See Figure 1)

Follow instructions supplied with stabilizer bar kits. If using tubular stabilizer bars, attach a boss mounted emergency shut-off valve to the valve mounting plate using the three (3) flat-head Allen screws provided. Tighten securely.

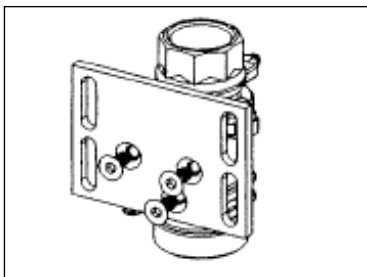

**Figure 1 (plate required for tubular stabilizer bars only)**

### Step #2 (See Figure 2)

Thread a riser pipe (or flex connector) into the bottom of the emergency shut-off valve. Thread the FlexWorks tee (if the connection is to be a junction) or FlexWorks elbow (if the connection is to be an end connection) onto the bottom of the riser pipe. The riser pipe length should be sized so that when the emergency shut-off valve shear groove is flush with the island finish grade, the centerline of the FlexWorks tee or elbow is in line with the associated pipe entry fittings.

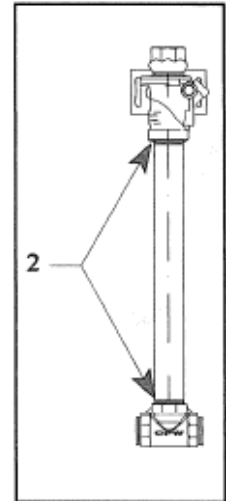

**Figure 2**

### Determining Pipe Entry Height

Pipe entries are generally located as close to the bottom of the dispenser sump as possible. However, to maintain the proper piping slope back to the UST, it may be necessary to raise the height of the pipe entries into the dispenser sump. The sump mounting frame can be lowered by cutting off a portion of the sump top along the top two ribs. Cut the sump off flush at the desired height along an inward or outward facing corrugation of the top two ribs. **Do not cut the sump top off past the bottom of the second rib from the top.**

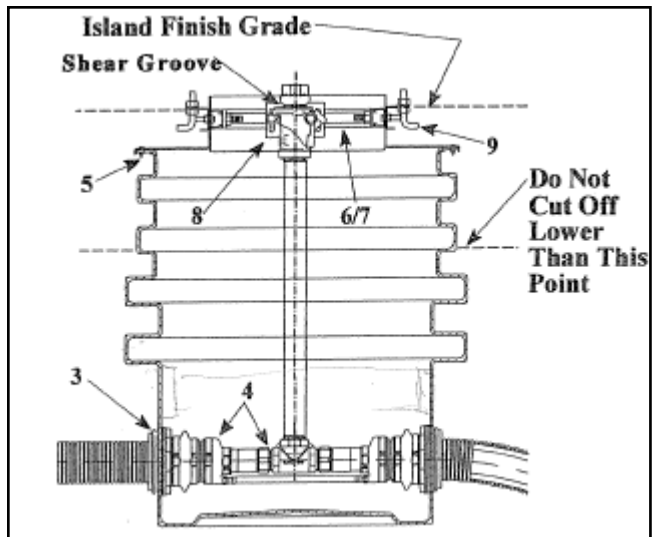

**Wide Access Sump Installation**

### **Step #3 - Install Pipe Entry Fittings**

Install the appropriate FlexWorks pipe and conduit entry fittings into the dispenser sump wall at the proper locations. The location of each pipe entry fitting should correspond with the product inlet locations for the dispenser that is to be installed. (Refer to the appropriate FlexWorks Entry Fitting Installation Instructions).

### **Step #4 - Make Piping Connections**

Insert the shear valve/riser assemblies into the containment chamber and make the appropriate piping and test boot connections.

### **Step #5 - Attach Sump Mounting Frame**

Apply a bead of Urethane Sealant (p/n SL-1000) to the flange on the containment chamber. Place the sump frame on top of the chamber. Drill out holes in the chamber through the frame using a 3/16" drill bit. Attach with the supplied screws and wing nuts.

### **Step #6 - (See Figure 6A/6B)**

Insert the spring loaded clamp nuts into dispenser side struts and rotate into position. Four (4) clamp nuts are used for each stabilizer bar. (Clamp nuts supplied in stabilizer bar kit).

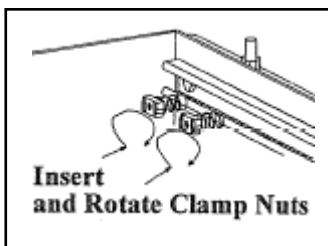

Figure 6A

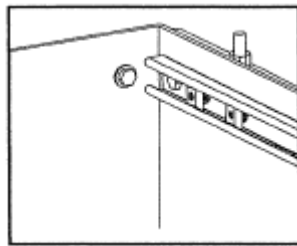

Figure 6B Clamp Nuts Installed

### **Step #7 - (See Figure 7A/7B)**

Install the FlexWorks emergency valve stabilizer bars according to the instructions that are included with the bars. Loosely attach the appropriate FlexWorks stabilizer bars to the side struts by fastening the bolts complete with lock washers to the clamp nuts previously installed in the side struts. Shims are provided to insert into the gap between the bar and the side struts if necessary (All hardware is supplied in stabilizer bar kit).

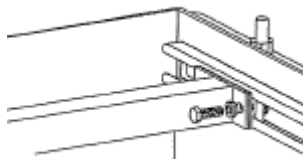

Figure 7A

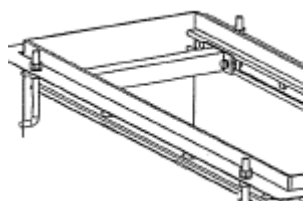

Figure 7B

### **Step #8 - (See Figure 8A/8B)**

Attach the emergency shut-off valve plate to the stabilizer bar using two (2) U-bolts, washers, and lock washers. Follow the emergency shut-off valve mounting instructions to ensure proper valve positioning. Adjust entire assembly as necessary and then secure all stabilizer bar and shear valve mounting hardware. Tighten securely. (Stabilizer bar, U-bolts, washers, and lock washers are supplied in stabilizer bar kit).

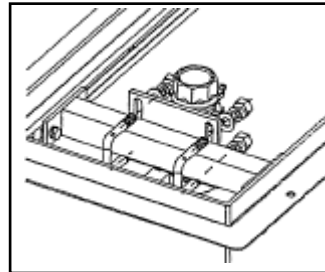

Figure 8A

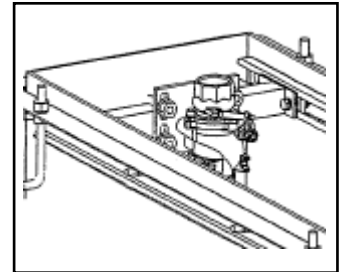

Figure 8B

### **Step #9**

Install the provided concrete anchor bolts in the set of holes in the sump mounting frame that matches the footprint of the dispenser to be installed. (**Note: Make sure bolts are in correct holes before pouring concrete. If holes in sump frame do not match dispenser frame, additional holes can be drilled. It may be necessary to install the bolts in the concrete outside of the frame to match some dispenser models.**)

### **Leak Testing**

After all connections are made, fill the sump with water. A drop in the water level within 1 hour indicates a leak that must be corrected before backfilling.

### **Backfilling**

Rounded pea gravel with a minimum diameter of 1/8" and a maximum diameter of 3/4" should be used for backfill around FlexWorks Dispenser Sumps. To prevent sump distortion, avoid dumping pea gravel directly onto the dispenser sumps when backfilling.

### **Maintenance**

FlexWorks sumps are designed to provide secondary containment of dispensers and piping connections. Sumps should be regularly inspected and checked for the presence of petroleum products. Damage or leaks in piping, sumps, and fittings should be repaired promptly. Third party approved liquid sensors should be installed in every sump. Any liquid present in the sump should be promptly removed and disposed of properly.

## Wide Access Dispenser Sump Piping Connections - Retractable System

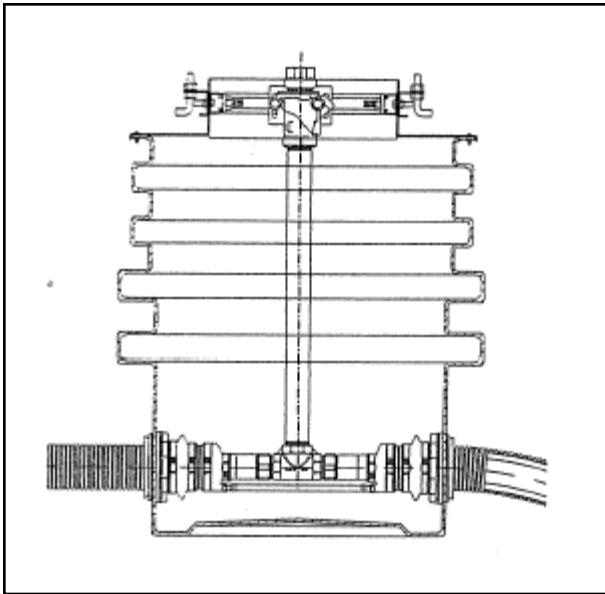

Junction Sump - Retractable System

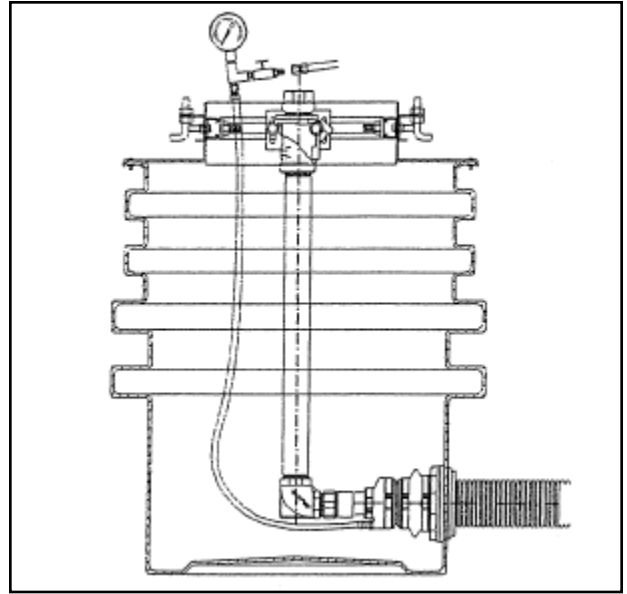

End Sump - Retractable System

## Wide Access Dispenser Sump Piping Connections - Direct Bury System

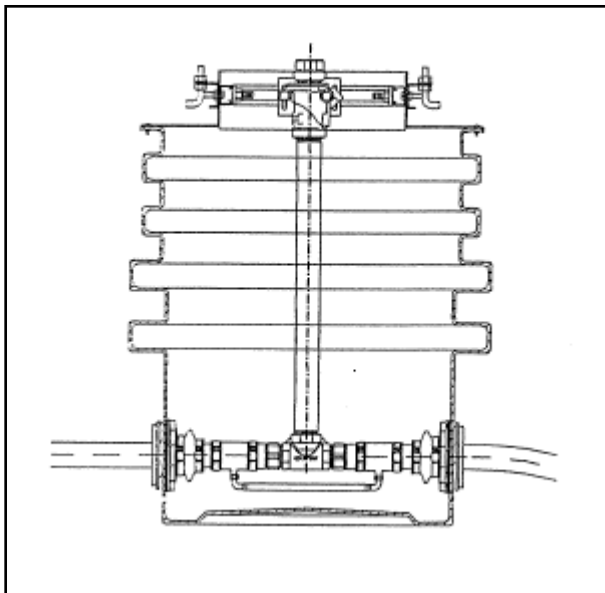

Junction Sump - Direct Bury System

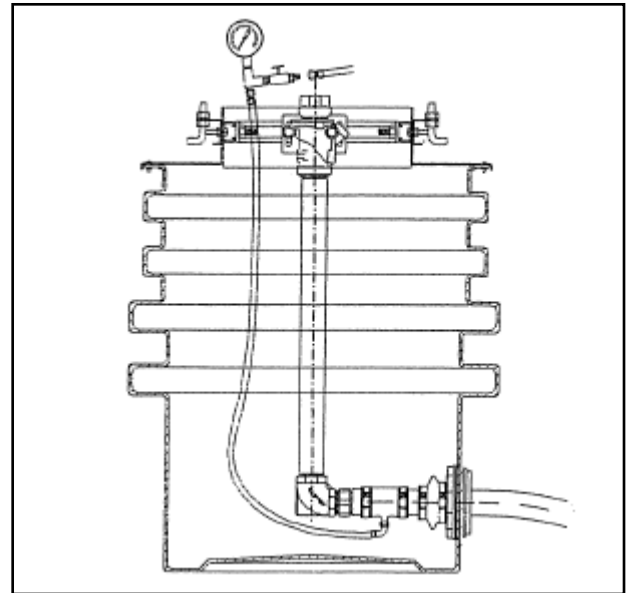

End Sump - Direct Bury System

**Notice:** FlexWorks products must be used in compliance with applicable federal, state, and local laws and regulations. Product selection should be based on physical specifications and limitations and compatibility with the environment and material to be handled. OPW makes no warranty of fitness for a particular use. All illustrations and specifications in this literature are based on the latest production information available at the time of publication. Prices, materials, and specifications are subject to change at any time, and models may be discontinued at any time, in either case, without notice or obligation.

### **Product Warranty**

OPW warrants that products sold by it are free from defects in materials and workmanship for a period of one year from the date of shipment by OPW. As the exclusive remedy under this limited warranty, FlexWorks by OPW, Inc., will at its sole discretion, repair, replace, or issue credit for future orders for any product that may prove defective within the one year period. This warranty shall not apply to any product that has been altered in any way, which has been repaired by any party other than a service representative authorized by OPW or when failure is due to misuse, conditions of use, or improper installation or maintenance. Neither OPW Fueling Containment Systems nor OPW shall in any instance have any liability whatsoever for special, incidental or consequential damages to any party and shall have no liability for the cost of labor, freight, excavation, clean up, downtime, removal, reinstallation, loss of profit, or any other cost or charges in excess of the amount of the original invoice for the products.

THIS WARRANTY IS IN LIEU OF ALL OTHER WARRANTIES, EXPRESS OR IMPLIED, AND SPECIFICALLY THE WARRANTIES OF MERCHANTABILITY AND FITNESS FOR A PARTICULAR PURPOSE. THERE ARE NO WARRANTIES WHICH EXTEND BEYOND THE DESCRIPTION ON THE FACE HEREOF.

### **IMPORTANT INFORMATION - FOLLOW ALL INSTRUCTIONS**

Please contact your OPW-FCS sales representative or OPW-FCS customer service representative at 1-800-422-2525 for OPW-FCS products installation procedures. All OPW-FCS literature including installation instruction sheets and manuals can be accessed from the OPW-FCS website at: [www.opwfcs.com](http://www.opwfcs.com).



**OPW Fueling Containment Systems**  
**3250 US 70 Business West**  
**Smithfield, NC 27577**  
**Customer Service: (800)-422-2525**  
**Customer Service Fax: (800)-421-3297**  
**Technical Questions: (919)-934-2786**  
**Literature Requests: (919) 934-2786**  
**[www.opwfcs.com](http://www.opwfcs.com)**

