



OPW Installation and Maintenance Instructions

OPW 61JSK-4400 Jack Screw Kit

IMPORTANT: Please read these warnings and assembly instructions completely and carefully before starting. Failure to do so may cause product failure, or result in environmental contamination due to liquid leakage into the soil, creating hazardous spill conditions.

IMPORTANT: Check to make sure the product is intact and undamaged and all parts have been supplied. Never substitute parts for those supplied. Doing so may cause product failure.

WARNING-DANGER: Using electrically operated equipment near gasoline or gasoline vapors may result in a fire or explosion, causing personal injury and property damage. Be sure that the working area is free from such hazards, and always use proper precautions.

NOTE: At all times when product is in the storage tank keep the riser pipe capped, so the vapors cannot escape into the environment.

Notice: OPW products must be used in compliance with applicable federal, state, and local laws and regulations. Product selection should be based on physical specifications and limitations and compatibility with the environment and material to be handled. All illustrations and specifications in this literature are based on the latest production information available at the time of publication. Prices, materials, and specification are subject to change at any time, and models may be discontinued at any time, in either case, without notice or obligation.

Standard Product Warranty

OPW warrants that products sold by it are free from defects in materials and workmanship for a period of one year from the date of manufacture by OPW (ECO products two years from date of manufacture.) Proof of purchase may be required. As the exclusive remedy under this limited warranty, OPW, will at its sole discretion, repair, replace, or issue credit for future orders for any product that may prove defective within the one year date of manufacture period (repairs, replacements, or credits may be subject to prorated warranty for remainder of the original warranty period, complete proper warranty claim documentation required.) This warranty shall not apply to any product that has been altered in any way, which has been repaired by any party other than a service representative

authorized by OPW, or when failure is due to misuse, or improper installation or maintenance. OPW shall have no liability whatsoever for special, incidental or consequential damages to any party, and shall have no liability for the cost of labor, freight, excavation, clean up, downtime, removal, reinstallation, loss of profit, or any other cost or charges.

For any product certified to California 2001 standards, OPW warrants that product sold by it are free from defects in material and workmanship for a period of one year from date of manufacture or one year from date of registration of installation not to exceed 15 months from date of manufacture by OPW.

THIS WARRANTY IS IN LIEU OF ALL OTHER WARRANTIES, EXPRESS OR IMPLIED, AND SPECIFICALLY THE WARRANTIES OF MERCHANTABILITY AND FITNESS FOR A PARTICULAR PURPOSE. THERE ARE NO WARRANTIES, WHICH EXTEND BEYOND THE DESCRIPTION ON THE FACE HEREOF.

61JSK-4400 Performance Specifications:

This OPW Jack Screw Kit is designed to lock an OPW 61SO-EVR Series Overfill Valve or 61T Drop Tube into an OPW 1-2100-EVR (or Multi-Port 500) Series Spill Container Base below the outlet of the drain valve.

Torque Specification:

1/4-20 Screw, 3.0 ft-lbs minimum to 4.5 ft-lbs maximum.

4" Nipple, 125 ft-lbs minimum to 250 ft-lbs maximum.

4" NPT Thread, 125 ft-lbs minimum to 250 ft-lbs maximum.

**OPW NO. 61JSK-4400 JACK SCREW KIT
INSTALLATION INSTRUCTIONS:**

Step 1

Remove any old or dried pipe dope and metal burrs from top of riser pipe. Apply a gasoline resistant pipe dope on the threads of an OPW FSA-400 Face Seal Adapter and install onto the riser pipe. Torque to 125 ft-lbs min. to 250 ft-lbs max, 4"NPT using the OPW 61SA-TOOL.

Step 2:

Install the OPW 1-2100-EVR or POMECEO 500 Series Spill Container in accordance with the OPW Installation Instructions supplied with the product.

Step 3: (See Figure 2 & 2A)

Assemble and Install the OPW Drop Tube in accordance with the OPW Installation Instructions supplied with the product.

Step 4: (See Figure 3)

Insert the Jack Screw Lower Plate (plate without threads) completely into the spill container base on top of the drop tube flange with the screw pockets facing up.

Step 5: (See Figure 5)

Assemble screws into upper plate. Adjust the screws so that the top plate will be located just below the bottom of the threads in the spill container base when the assembly is inserted into the spill container. Apply the supplied thread sealant to the threads above the top plate on all three screws on the Jack Screw Top Assembly.

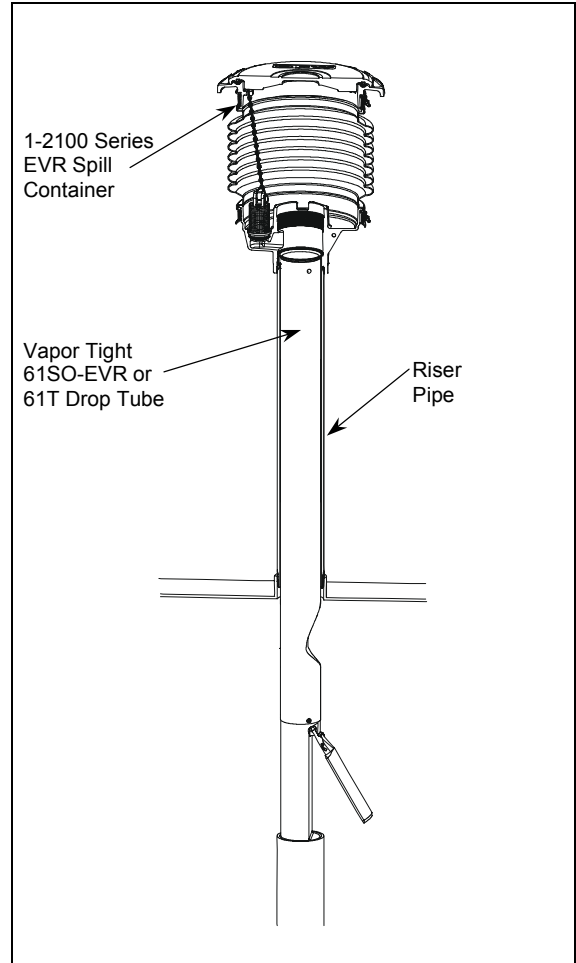

Figure 2a

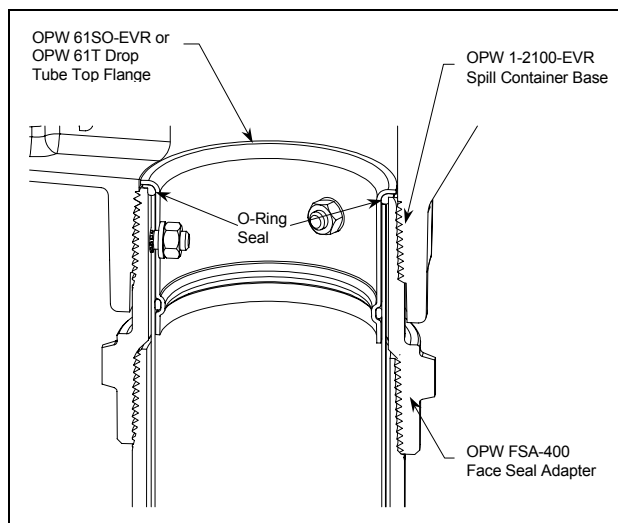

Figure 2

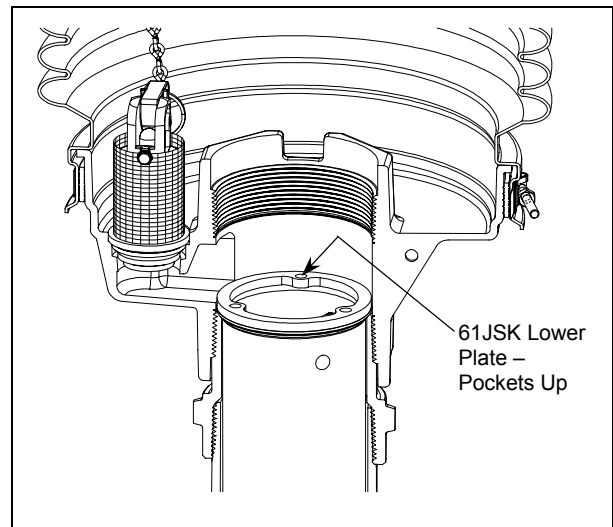

Figure 3

Step 6: (See Figure 5)

Install the Jack Screw Assembly into the spill container base. Make sure the bottoms of the three screws are seated in the pockets on the Jack Screw Lower Plate.

Step 7: (See Figure 6)

Apply a gasoline resistant pipe dope on the threads of a 4" nipple. Install the 4" nipple into the spill container and tighten securely. (Recommended torque, 4"NPT, 125 ft-lbs min. to 250 ft-lbs max.)

Note: The top plate should not be in contact with the nipple at this point. If the nipple hits the top plate while being tightened, remove the nipple, lower the top plate on the jack screw below the threads on the spill container, and then reinstall the nipple.

Step 8: (See Figure 7)

Using a long screwdriver, alternately and evenly tighten the three (3) screws on the Jack Screw Assembly until the Upper Plate contacts the bottom of the 4" nipple. Tighten the three (3) screws evenly and securely with a torque of 3.0 ft-lbs min. to 4.5 ft-lbs max to ensure that the drop tube flange is sealed securely to the riser pipe.

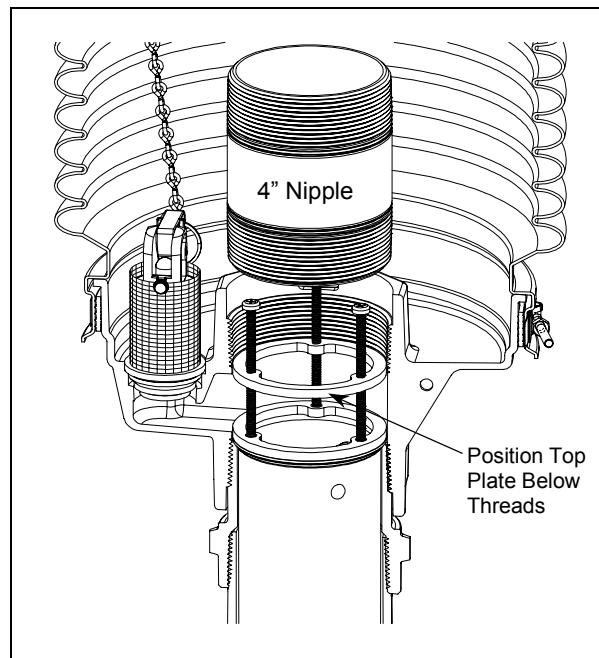

Figure 6

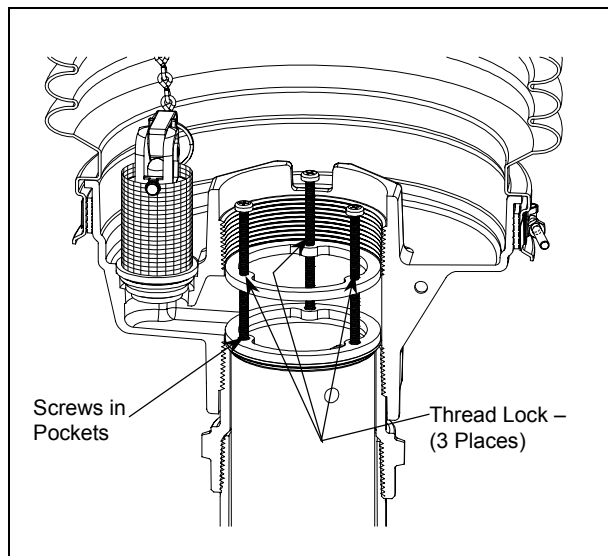

Figure 5

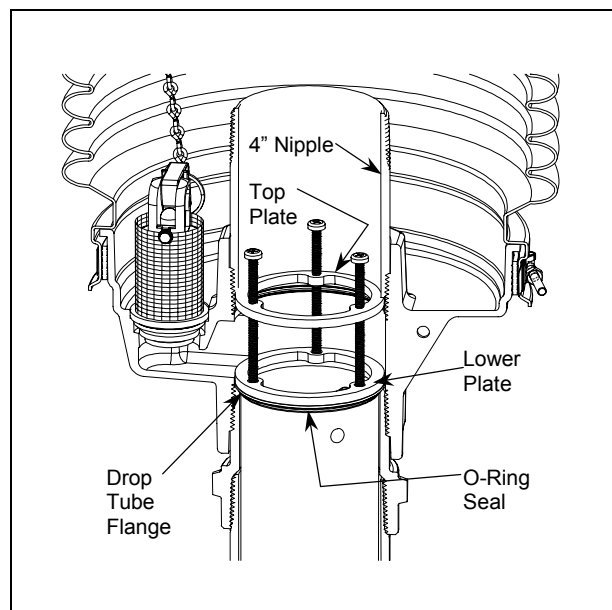

Figure 7

Step 9: (See figure 8)

Assembly of the Jack Screw Kit is now complete. Proceed to installation of the OPW 61SALP-EVR Rotatable Product Adaptor and OPW 634TT Cap in accordance with the OPW Installation Instructions supplied with the product.

Operation and Maintenance:

If a leak develops at the drop tube. Re-torque the (3) screws on the Jack Screw. (Torque value: 3.0 ft-lbs min. to 4.5 ft-lbs max.) If this does not correct the leak, check for burrs, clean the sealing surface on the FSA-400 and replace the o-ring on the drop tube.

NOTE: Loctite 242, thread locker, must be reapplied each time the screws are adjusted.

Important: Leave these instructions with Station Operator.

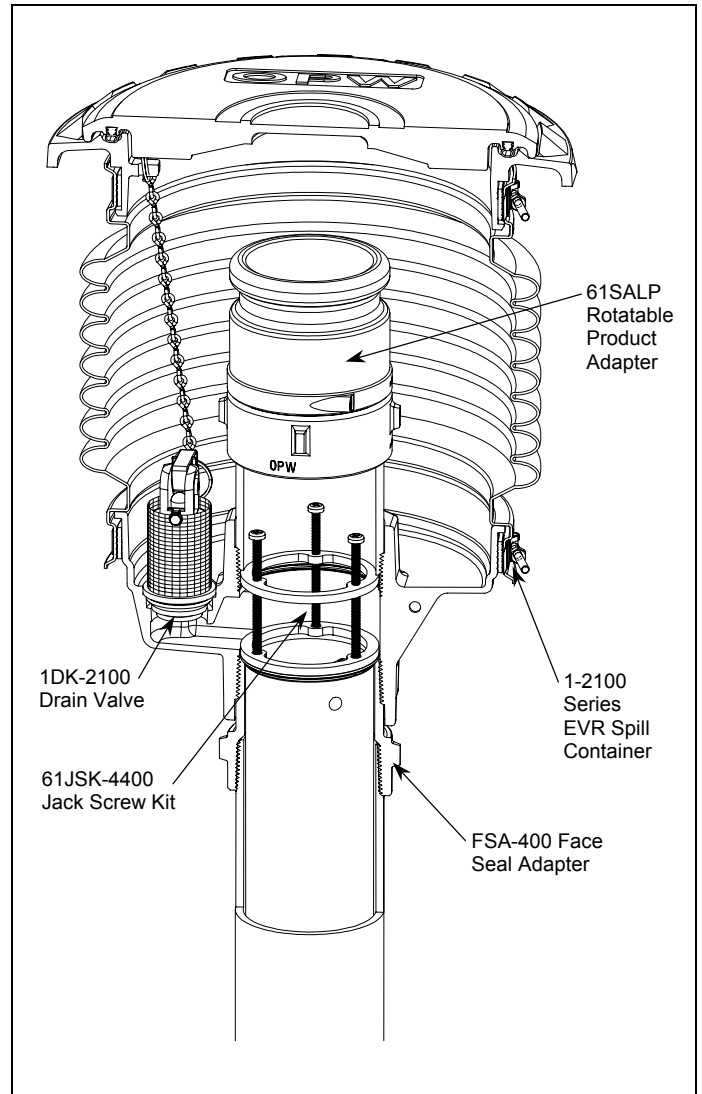

Figure 8



P.O. Box 405003 * Cincinnati, Ohio 45240-5003
1-800-422-2525 Domestically
513-870-3315 Internationally
www.opw-fc.com

Copyright, 2002 - OPW Fueling Components Inc., Cincinnati, OH
Printed in U.S.A. p/n H14727PA – 9/02