

# OPW INSTRUCTIONS INSTALLATION PROCEDURE

H12133M  
NOVEMBER 1993

## OPW 60V SERIES VAPOR LINE SHEAR VALVE

**IMPORTANT:** The OPW 60V Series Vapor Line Shear Valve is an emergency breakaway designed for the vapor line in Stage II applications.

The valve, intended for installation at the base of the dispenser pedestal, is designed to break at the shear groove in the event of severe impact, helping to minimize the loss of vapors and damage to underground piping.

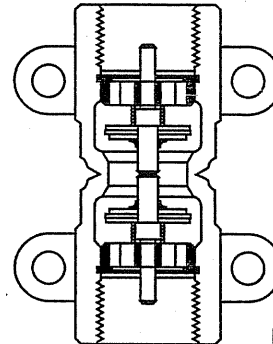

OPW 60V (1000) 1" VAPOR VALVE - UNPOPPETED  
OPW 60VP (1001) 1" VAPOR VALVE - POPPETED

FIGURE 1

**WARNING:** Proper operation is dependent on proper installation. The following instructions are provided to assist you in properly installing your 60V Series Valve. The valve body must be rigidly anchored to a structural member within the island and also to the dispenser to insure breakage at the shear groove in the event of severe impact. Failure to follow these instructions or to provide a rigid mounting to both structures may result in a failure of the valve to break at the shear groove. This may result in a loss of vapors or damage to underground piping, which could lead to a potentially hazardous condition.

### STEP 1

#### HOW TO ATTACH VALVE TO RISER STUB:

##### Coat Riser Stub:

NOTE: USE A UL CLASSIFIED, NON-HARDENING GASOLINE RESISTANT PIPE-JOINT SEALING COMPOUND ON THE DISPENSER CONNECTION BEFORE ATTACHING THE VALVE TO THE RISER STUB. DO NOT USE TEFLON TAPE.

Thread valve tightly onto riser stub by grasping inlet end surface "A".

A dirt protector is supplied in the outlet end of the valve and should remain in place until final connection is made between the valve and pedestal.

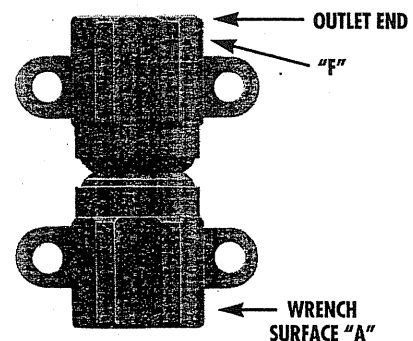

FIGURE 2

### STEP 2

#### HOW TO ATTACH OUTLET END OF VALVE TO DISPENSER PIPING:

##### Remove Dirt Protector.

Hold valve steady with one wrench on hex surface "F" (Figure 2). NOTE: IF WRENCH IS TURNED, SHEAR SECTION WILL BREAK.

The second wrench is used to tighten the pipe being attached.

**CAUTION: TIGHTEN THREADS UNTIL TIGHT SEAL IS OBTAINED. ADDITIONAL TIGHTENING MAY CAUSE THE BODY TO CRACK AND ALLOW VAPOR LEAKAGE DURING TESTING OR WHILE IN SERVICE.**

### STEP 3

#### OPW RECOMMENDED INSTALLATIONS:

The shear groove must be at the same level or a maximum of 1/2" above or below the top of the pedestal island. Failure to install the shear groove at this level may prevent the valve from breaking-off in the event of severe impact, resulting in a hazardous condition.

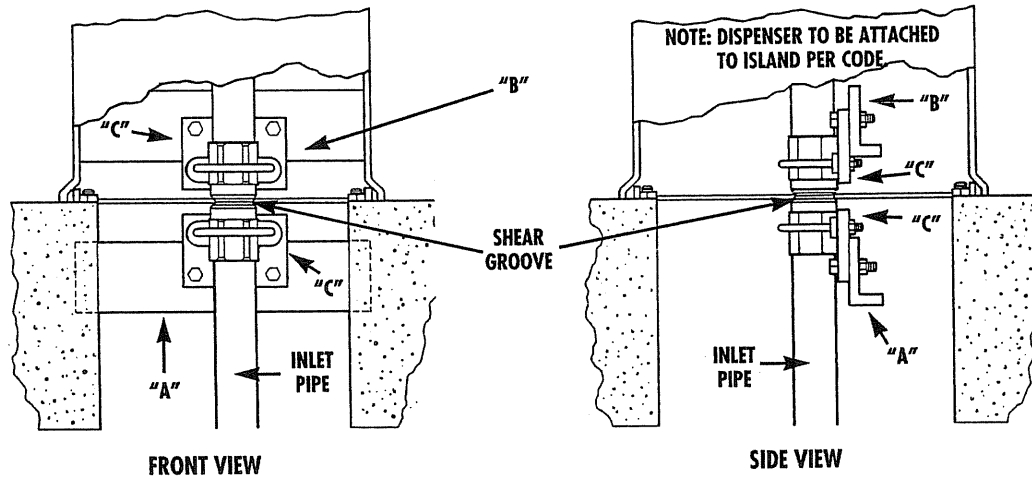

Angle iron "A" is rigidly supported within the island form by embedding it in concrete. Angle iron "B" is rigidly supported to the pedestal. Short brackets "C" are each bolted to the valve using U-bolt kit 60VK (1002) or bolt and nut kit 60VK (1003). Angle brackets "C" are then bolted to angle brackets "A" and "B" using four (4) 3/8" 16 bolts and nuts to insure the valve and inlet piping are rigid.

OPW 60V Series Vapor Line Shear Valves are listed by Underwriter's Laboratories, Inc., ETL Testing Laboratories, Inc. and designed to meet the requirements of NFPA code 30A section 4-3.7.



FIGURE 3

#### PRODUCT WARRANTY:

All OPW parts and products are thoroughly inspected and tested from the time raw material is received at our plant until the product is completed. We guarantee that all products are free from defects in materials and workmanship for a period of one year from the date of shipment. Any product that may prove defective within that one year period will, at OPW's option, be promptly repaired or replaced or credit given for future orders. This warranty shall not apply to any product which has been altered in any way, which has been repaired by any party other than an authorized OPW service representative, or when failure is due to misuse or conditions of use. OPW shall have no liability for special or consequential damages to any party, and shall have no liability for labor costs, freight costs or any other cost or charges in excess of the amount of the invoice for the products. THIS WARRANTY IS IN LIEU OF ALL OTHER WARRANTIES, EXPRESSED OR IMPLIED, AND SPECIFICALLY THE WARRANTIES OF MERCHANTABILITY AND FITNESS FOR A PARTICULAR PURPOSE. THERE ARE NO WARRANTIES WHICH EXTEND BEYOND THE DESCRIPTION ON THE FACE HEREOF. WARNING: OPW products should be used in compliance with applicable federal, state and local laws and regulations. Product selection should be based on physical specifications and limitations and compatibility with the environment and material to be handled. OPW reserves the right to change specifications at any time without incurring obligations.

# OPW

FUELING COMPONENTS

A DOVER RESOURCES COMPANY

P.O. Box 405003 • Cincinnati, Ohio 45240-5003  
(513)870-3219 • (800)422-2525 (Orders Only)  
(513)870-3100 (Other Calls)