



Leak Sensor *Plus*

Tank Monitoring System

Installation & Operation Manual

OPW Fuel Management Systems - System and Replacement Parts Warranty Statement

Effective September 1, 2002

System and Replacement Parts Warranty

OPW Fuel Management Systems warrants that all OPW Tank Gauge and Petro Vend Fuel Control systems supplied by OPW Fuel Management Systems to the Original Purchaser will be free from defects in material and/or workmanship under normal use and service for a period of 12 months from the date of installation or 15 months from the date of shipment. Additionally, OPW Fuel Management Systems warrants that all upgrades and replacement parts (new and remanufactured) supplied by OPW Fuel Management Systems will be free from defects in material and workmanship under normal use and service for a period of 90 days from the date of installation or for the remainder of the system's original warranty, whichever is greater, as set forth in the first sentence of this statement. The foregoing warranties will not extend to goods subjected to misuse, neglect, accident, or improper installation or maintenance or which have been altered or repaired by anyone other than OPW Fuel Management Systems or its authorized representative.

The buyer's acceptance of delivery of the goods constitutes acceptance of the foregoing warranties and remedies, and all conditions and limitations thereof.

If a claim is made within the warranted time period that any equipment and/or remanufactured part is defective in material or workmanship under normal use and service, such equipment and/or remanufactured part shall be returned to OPW Fuel Management Systems, freight prepaid. If such equipment or remanufactured part is found by OPW Fuel Management Systems in its sole judgment, to be defective in material or workmanship under normal use and service, OPW Fuel Management Systems, shall, at its sole option, repair or replace such equipment and/or remanufactured part (excluding, in all instances, fuses, ink cartridges, batteries, other consumable items, etc.)

The warranties, as set forth above, are made expressly in lieu of all other warranties, either expressed or implied, including, without limitation, warranties of merchantability and fitness for any particular purpose and of all other obligations or liabilities on OPW Fuel Management Systems part. Further, OPW Fuel Management Systems neither assumes, nor authorizes any other person to assume for it, any other liability in connection with the sale of the systems, or any new/replacement part that has been subject to any damage from any act of nature or any *force majeure*.

The term "Original Purchaser" as used in these warranties shall be deemed to mean the authorized OPW Fuel Management Systems distributor to which the system or any new/replacement part was originally sold. These warranties may be assigned by the original purchaser to any of its customers who purchase any OPW Fuel Management Systems systems or new/replacement parts.

The sole liability of OPW Fuel Management Systems, for any breach of warranty, shall be as set forth above. OPW Fuel Management Systems does not warrant against damage caused by accident, abuse, faulty or improper installation or operation. In no event shall manufacturer's liability on any claim for damages arising out of the manufacture, sale, delivery or use of the goods exceed the original purchase price of the goods. In no event shall OPW Fuel Management Systems be liable for any direct, indirect, incidental or consequential damage or loss of product.

Contents

Introduction	1
Additional United States Requirements	2
General Description	3
Features & Benefits.....	3
Codes and Standards	3
Console Specifications.....	4
Available Sensors	4
Installing the Console	5
Conduit Requirements	5
Choosing a Mounting Location.....	5
Console Wiring.....	8
Installing the Sensors - Overview	11
Hazardous Location Precautions	11
Placing the Sensors	12
Wiring the Sensors.....	12
Sealing Connections With the Seal Packs	14

Sensor Specifics 15

Q0003-005 Hydrostatic Interstitial Sensor 15

Q0003-006 Basic Interstitial Sensor..... 16

Q0003-009 Liquid Float Sensor 18

Q0003-010 Vapor Sensor 19

Q0003-011/Q0003-012 Dual-Level Float Sensor 20

Q0003-013 Interstitial Sensor 22

Post-Installation Checklist 25

Calibrating the Console 27

Operation 29

LED Indicators..... 29

Silencing Alarms 30

Resetting the System 30

In Case of Problems 31

List of Figures

Figure 1: <i>Internal View of Console</i>	6
Figure 2: <i>Console Mounting Dimensions</i>	7
Figure 3: <i>Console Wiring Connectors</i>	8
Figure 4: <i>Wiring for the CN2 and CN3 Connectors</i>	9
Figure 5: <i>Wiring for the CN1 Sensor Connector</i>	9
Figure 6: <i>Connecting Sensors to the Console</i>	11
Figure 7: <i>Seal Pack and Junction Box Overviews</i>	14
Figure 8: <i>Hydrostatic Interstitial Sensor</i>	15
Figure 9: <i>Basic Interstitial Sensor Installation in a FIBERGLASS Tank</i> ..	16
Figure 10: <i>Typical Basic Interstitial Installation in a STEEL Tank</i>	17
Figure 11: <i>Typical Liquid Float Sensor Installation</i>	18
Figure 12: <i>Typical Vapor Sensor Installation</i>	19
Figure 13: <i>Typical Dual-Level Float Sensor</i>	20
Figure 14: <i>Typical Interstitial Sensor Installation</i>	22
Figure 15: <i>Leak Sensor Plus Front Panel</i>	29

Introduction

This manual contains installation and operating instructions for the OPW Fuel Management Systems Leak Sensor Plus. Any inquiries regarding the system or these instructions should be directed to:

**OPW Fuel Management Systems
Leak Sensor Plus Products
6900 Santa Fe Drive
Hodgkins IL 60525
708-485-4200**

Important safety messages are located throughout this manual. Be alert to the possibility of personal injury.

Warnings

This system is installed and operated near the highly combustible environment of an underground fuel storage tank. It is *essential* that you carefully read and follow the warnings and instructions in this manual to protect yourself and others from serious injury, explosion, or electrical shock.

- The Leak Sensor Plus is designed to detect liquid (water and fuel) in a safe and reliable manner when installed as described in this manual. Deviation from these instructions, including installing or using non-approved components, could result in unsafe conditions or unreliable operation and will void the warranty.
- Safe installation is the responsibility of the installer and user.
- For safety reasons, low voltages are used in sensors. HOWEVER -- you STILL must keep that wiring physically separated from any other wiring. Failure to do so may create situations hazardous to people and/or property.
- Leaking underground tanks create serious environmental and health hazards.
- Failure to install this product in accordance with the instructions and warnings in this manual voids all warranties of this product.

- During installation and use of this product, you must comply with the National Electrical Code (NEC), federal, state, and local codes, and other applicable safety codes. Failure to comply with these warnings could result in serious personal injury, property loss, and equipment damage.
- Make sure vehicles **CANNOT** enter the work area while you are installing or servicing the sensors.
- All conduits must enter the console **ONLY** through specified conduit knockouts.

Additional United States Requirements

- Installation shall be in accordance with NEC (NFPA 70) and Automotive and Marine Service Station Codes (NFPA 30A and local codes).
- Wires for intrinsically safe sensors **MUST NOT** be run in conduit or areas of wire-ways (wiring troughs) that contain wires from any other device except where separated in accordance with NEC ANSI/NFPA 70 ARTICLE 504-30.
- The conductors of different intrinsically safe circuits that run in the same cable/conduit shall have at least 0.01" thick insulation.
- Circuits within the sensors and console barriers form an intrinsically safe, energy-limited system. The sensors, when connected to the console, are intrinsically safe for use in Class I, Division 1, Group D Hazardous (classified) locations when installed according to these instructions.

General Description

Leak Sensor Plus is an economical solution to regulatory compliance for underground storage tanks (UST) and low cost inventory management for above ground storage tanks (AST).

The easy-to-use Leak Sensor Plus has four-sensor inputs for low cost monitoring of above ground and underground storage tanks.

You can configure each system with interstitial and containment sump monitoring sensors to meet regulatory compliance needs. Also, you can configure your Leak Sensor Plus with high and low level sensors for low cost inventory management.

Leak detection is provided by interstitial sensors between the walls of double-wall tanks, sensors in the sumps of double-wall piping systems, and sensors in the dispenser pan areas.

Features & Benefits

- System monitors up to four sensors
- Continuous, automatic leak sensing
- Audible alarm and visual display of sensor status
- Sensors are approved for hazardous location applications
- Low cost inventory management for ASTs and compliance for USTs
- Simple to use – no programming required

Codes and Standards

The latest editions of the following codes apply. In the event of discrepancies in specification codes or standards, the more stringent and/or local codes shall govern.

- NEC - National Electrical Code
- NEMA - National Electrical Mfg. Assoc.
- UL – Underwriter’s Laboratories

Console Specifications

Table 1: Console Specifications

Dimensions	8.25" W x 7.25" H x 4.25" D (21.0 x 18.4 x 10.8 cm)
Weight	3 lb (1.4 kg)
Operating Temperature Range	0° to 104°F (-18° to 40°C)
Mounting Locations	Non-hazardous area, indoors or outdoors
Power Requirements	115 VAC or 230 VAC, 50/60 Hz, 5W
Listings/Approvals	UL, cUL
Alarm Relay	24 VDC 30W, 125 VAC 50 VA contacts

Available Sensors

Table 2: Available Sensors

Sensor Part Number	Description
Q0003-005	Wet Interstitial Sensor (Flooded Space)
Q0003-006	Dry Interstitial Optic Sensor (Liquid Only)
Q0003-009	Liquid Float Switch
Q0003-010	Vapor Sensor
Q0003-011*+	Dual-Level Float Sensor (up to 5')
Q0003-012*+	Dual-Level Float Sensor (5' to 10')
Q0003-013	Dry Interstitial Flapper Sensor (Liquid Only)

* These sensors require 2 channels per sensor.

+ Q0003-011 and -012 sensors have not been evaluated by Underwriters Laboratories

Installing the Console

Warnings

- Make sure vehicles CANNOT enter the work area during installation or service.
- All conduits must enter the console ONLY through specified holes.
- Console AC power must be OFF when installing field data wiring and connecting sensors.

Conduit Requirements

- Use 1/2" metal conduit (PREFERRED) between the console and tank area. The conduit run must completely cover all wiring.
- **If you use PVC conduit (in accordance with NEC)** due to soil conditions, you MUST ground the junction box. Install a 12 gauge (minimum) stranded ground wire through the conduit between a ground lug in the junction box, and earth ground at the console.
- **Rigid metal conduit** must be used above grade to prevent electrical interference.
- **EYS seal-off fittings** are required in all conduits leaving Class 1 Hazardous locations. An EYS fitting or equivalent should be installed at the sensor and interface module ends of each conduit.
- **Maximum wire length** between console and sensors is 1,500 feet.

Choosing a Mounting Location

When mounting the console on the wall:

- Mount the console in a NON HAZARDOUS area.
- Attach all conduits to the knockouts provided in console bottom.
- Allow a minimum of 12" below the console for conduit access.
- Allow sufficient clearance on left side and front of console so door can open fully.

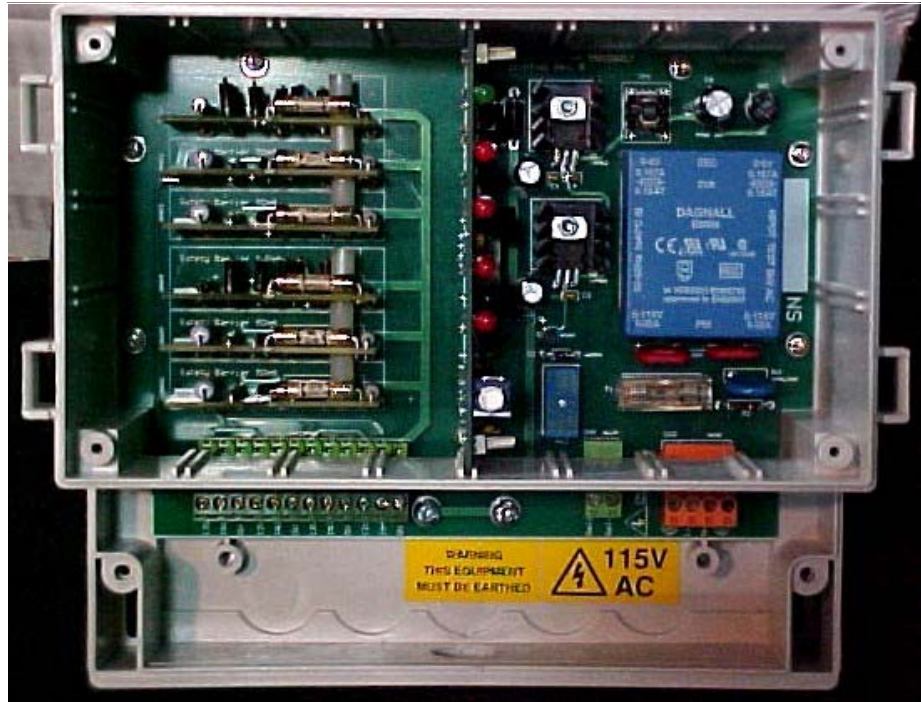

Figure 1: Internal View of Console

See *Figure 2* for a mounting “template”. See *Figure 15* on page 29 for an overview of the unit’s front panel.

The mounting keyhole slot at the top of the console has an opening for mounting hardware with a maximum head diameter of 3/8”, and 1/4” length.

The console’s bottom tab mounting holes are 0.25” diameter.

Console mounting hardware is not supplied with the console because the exact mounting method is up to the customer. Whatever is used, make sure the hardware will support the weight of the system and is the correct type for the installation.

1. Note the keyhole size for mounting hardware.
2. Install top screw.
3. Mount console on screw.
4. Level console box and secure bottom of console with two bottom screws.

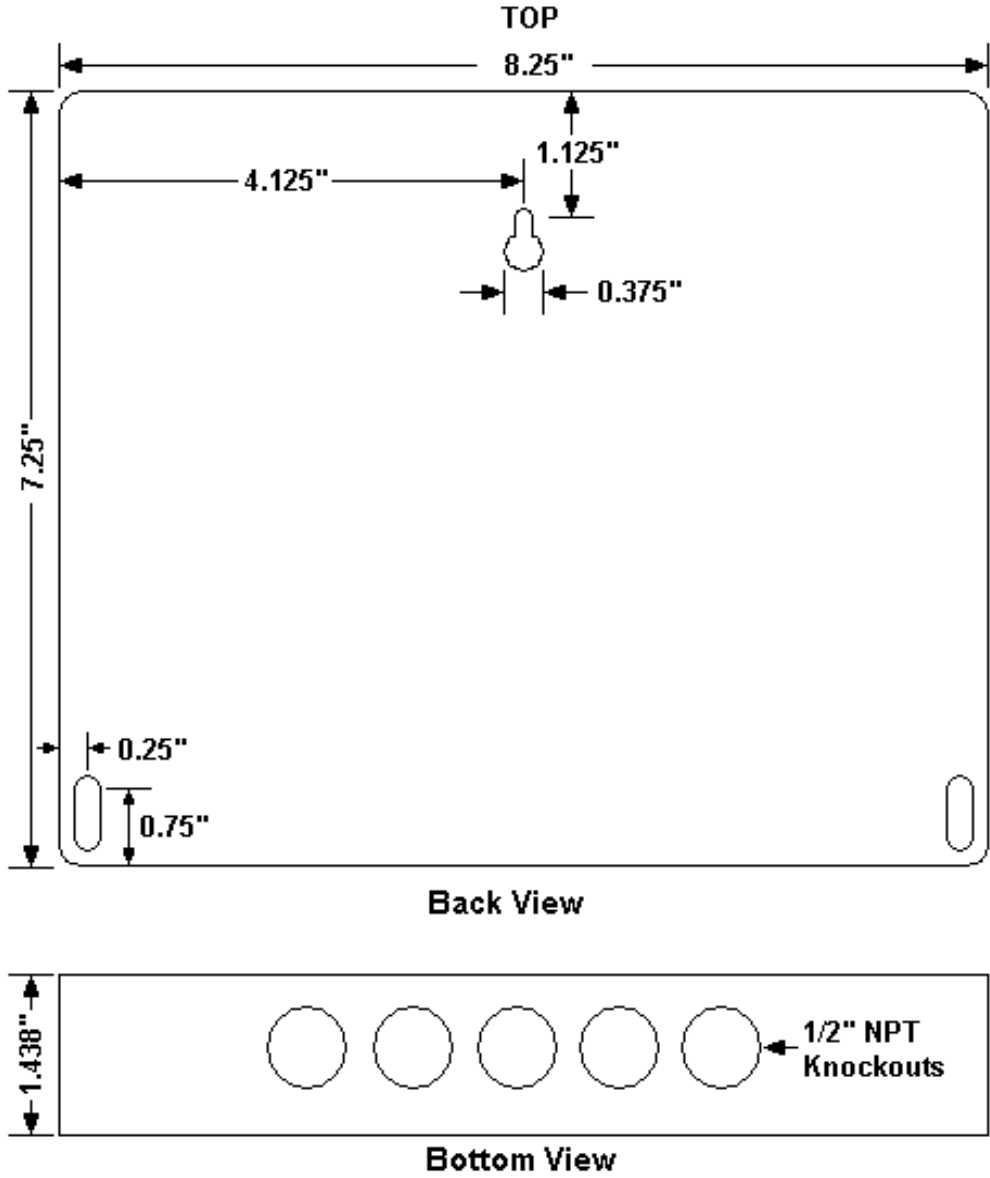
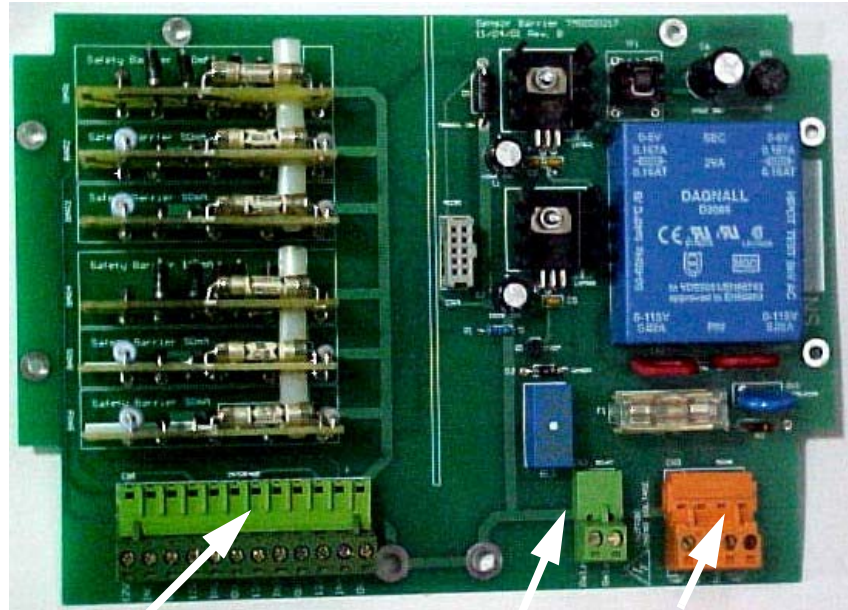

Figure 2: Console Mounting Dimensions

Console Wiring

Up to four sensors attach to the CN1 connector on the larger PC board. A normally open relay attaches to the CN2 connector, and power wiring goes to the CN3 connector. See *Figure 3*, *Figure 4* and *Figure 5*.



Connector CN1 for sensors, see *Figure 5* on page 9.

Connector CN2 for relay wiring, see *Figure 4* on page 9.

Connector CN3 for power wiring, see *Figure 4* on page 9.

Figure 3: Console Wiring Connectors

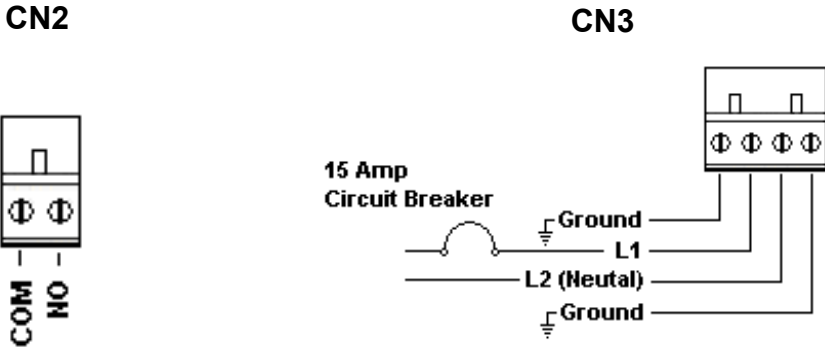

Figure 4: Wiring for the CN2 and CN3 Connectors

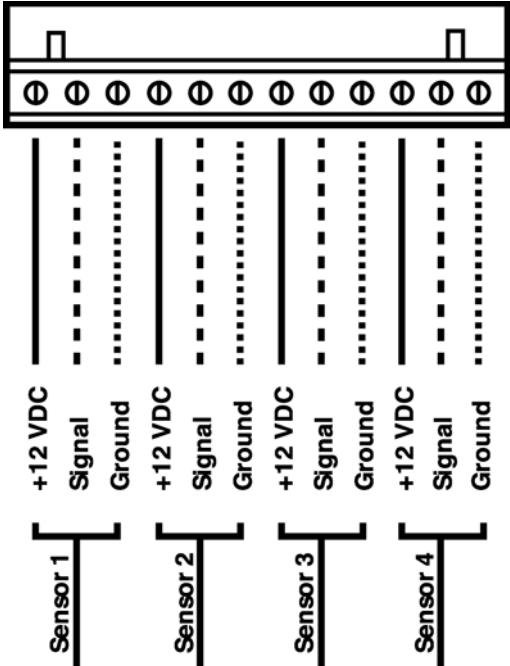

Figure 5: Wiring for the CN1 Sensor Connector

Installing the Sensors - Overview

Note

Refer also to individual sensor installation instructions on pages 15 to 22.

Hazardous Location Precautions

When installed and used as described in this manual, the leak sensors operate safely in Class I Div 1 hazardous locations. *Read and understand all instructions before installation.*

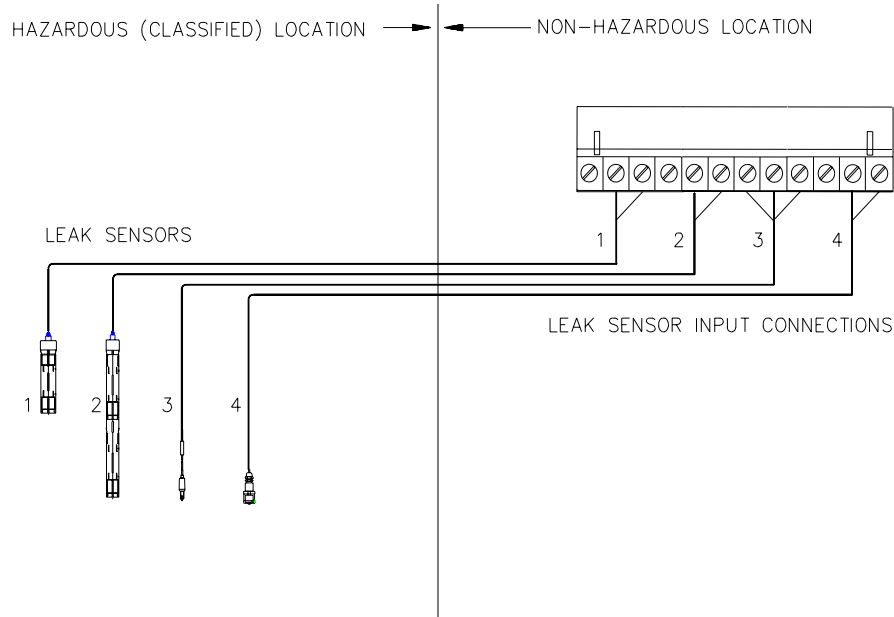

Figure 6: Connecting Sensors to the Console

Notes

Do NOT attach any equipment to the unit that generates or uses more than 250 VAC.

Use at least 18 AWG stranded field wiring between sensors and the console. This is per Article 504 of NEC. Three wires are required for Q0003 and -006 interstitial sensors. All others use two wires. Do NOT exceed 1500 feet!

Placing the Sensors

OPW Fueling Systems leak sensors monitor for liquids (in some cases distinguishing between fuel and water) in containment spaces in or around above ground or underground storage tank systems. These spaces may be one or more of the following:

- Containment pans under dispensers
- Piping containment sumps
- Tank interstitial spaces
- Monitoring wells
- Inside tanks for level alarms
- Any other type of containment spaces.

Wiring the Sensors

1. Pull 18 gauge, stranded wire through the installed conduit. Use *Table 3* to identify each wire set with sensor type and location and sensor wire color. Do not exceed 1500 feet.
2. Connect sensor wiring to field wiring *inside the junction box* (see *Figure 7* on page 14). Strip 1/2" insulation from each wire and twist wires together. Secure wires with wire nuts.
3. Seal all connections with the supplied epoxy seal packs (*Figure 7*).

4. Using *Table 3*, connect field wires at the Leak Sensor Interface Module to the correct terminals for your sensor. Insert screw type connector into the correct Interface receptacle.

Table 3: Sensor Wire Color Codes

Sensor Part Number	Description	+12V	SIGNAL	GROUND
Q0003-005	Wet Interstitial Sensor (Flooded Space)	<i>none</i>	WHITE	BLACK
Q0003-006	Dry Interstitial Optic Sensor (Liquid Only)	WHITE	RED	BLACK
Q0003-009	Liquid Float Switch	<i>none</i>	RED	BLACK
Q0003-010	Vapor Sensor	<i>none</i>	WHITE	BLACK
Q0003-011	*Dual-Level Float Sensor -- TOP	<i>none</i>	YELLOW	YELLOW
Q0003-011	*Dual-Level Float Sensor -- BOTTOM	<i>none</i>	RED	RED
Q0003-012	*Dual-Level Float Sensor -- TOP	<i>none</i>	YELLOW	YELLOW
Q0003-012	*Dual-Level Float Sensor -- BOTTOM	<i>none</i>	RED	RED
Q0003-013	Dry Interstitial Flapper Sensor (Liquid Only)	<i>none</i>	RED	BLACK

** Require two channels per sensor.*

Extra wires not listed in Table 3 may be ignored or cut off.

Sealing Connections With the Seal Packs

See *Figure 7*. Seal all wiring connections between the sensor and field wiring to prevent corrosion and bad connections. Use the supplied epoxy seal packs.

- Check that wires are twisted together and wire nuts are properly installed.
- Mix the brown and black epoxy resins thoroughly inside the packet.
- Force the epoxy mixture to one end of the packet. Trim off other end.
- Insert the wires and wire nuts into the packet. Make sure the mixture flows around the wires *and* into the ends of the wire nuts.
- Use wire tie to prevent leakage during curing process.

Warning

The field data cable insulation must be inserted into the epoxy mixture to block the path of vapors into the cable.

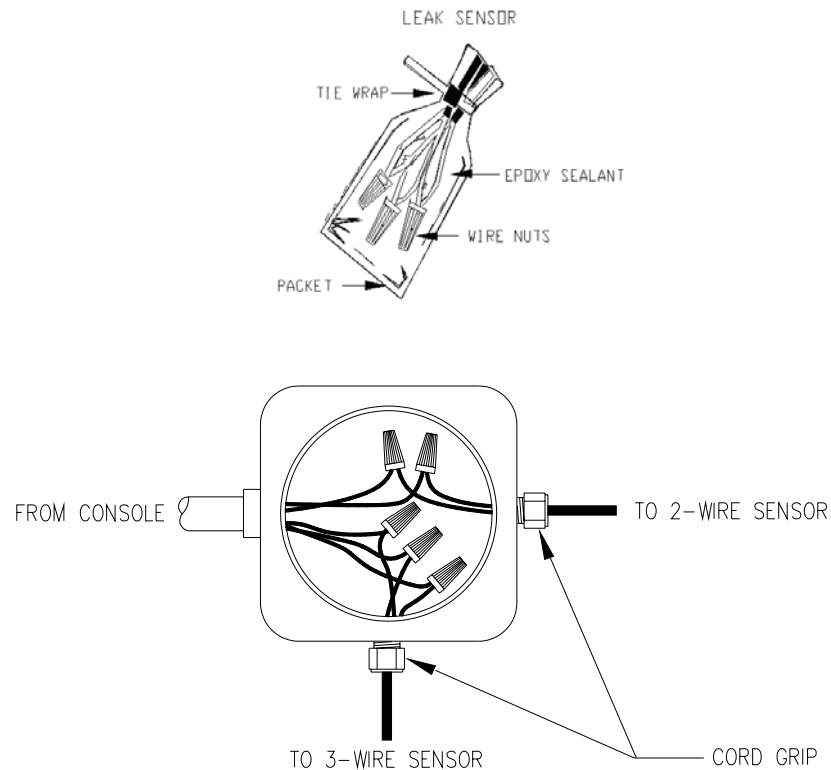

Figure 7: Seal Pack and Junction Box Overviews

Sensor Specifics

Q0003-005 Hydrostatic Interstitial Sensor

Specifications

Primary Use	Wet Interstitial (filled with brine/glycol solution)
Detects	Liquid Level change (loss and gain)
Temp. Range	-13 to 158 °F (-25 to 70 °C)
Dimensions	L = 17.5" (44.5cm) W = 2" (5cm); Level Variation: ±5"
Connections	2 wire (White / Black – no polarity)

Installation

1. Prepare the tank with 4.5" of liquid above the surface that the sensor will rest upon. Use only liquid specified by the tank manufacturer when adding liquid to the annular space of the tank.
2. Install the sensor as shown in *Figure 8*.

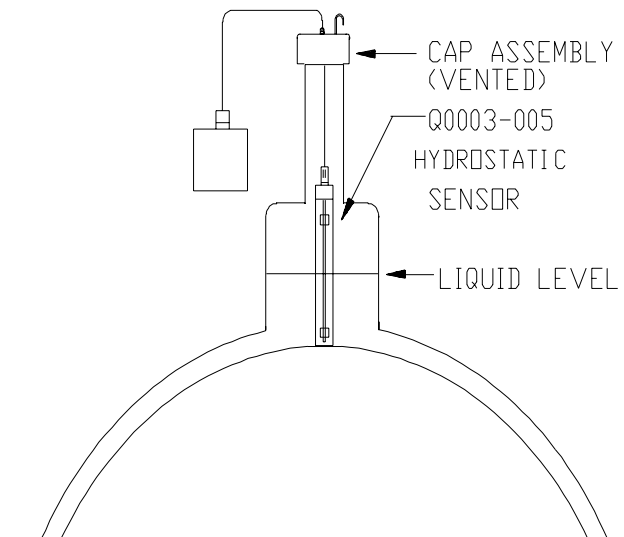

Figure 8: Hydrostatic Interstitial Sensor

3. Install a cap assembly (including a waterproof cord grip and inverted 'J' vent) on top of the riser with the sensor cord installed through the cord grip to prevent water (or product) leaking into the annular space.
4. Connect the sensor wires to the field wires in the junction box using the supplied wire nuts.
5. Seal electrical connections with epoxy seal packs (*Figure 7* on page 14).

Q0003-006 Basic Interstitial Sensor

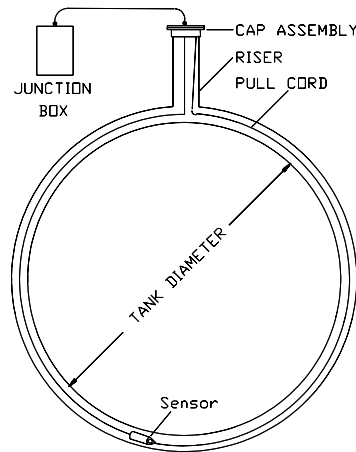

Figure 9: Basic Interstitial Sensor Installation in a FIBERGLASS Tank

Specifications

Primary Use:	Interstitial Space (fiberglass tanks)
Alternate Use:	Dispenser Pans and Sumps
Detects:	Liquids
Temp. Range:	-4 to 176 °F (-20 to 80 °C)
Dimensions:	L = 2.6" (6.6cm) W = .6" (1.5cm)
Connections:	3 wire (White = supply voltage, Red = signal, Black = common)

Installation in Fiberglass Tanks

1. See *Figure 9*. Determine tank inside diameter (TD).
2. Measure the riser height (RH) from top of tank to cap assembly.
3. Multiply the tank diameter (TD) x 1.4 and add the riser height (RH).
Formula = (TD) x 1.4 + (RH)
4. Measure the length from the sensor tip along the sensor cable and mark with tape or marker.
5. Attach the tank pull cord to the sensor and pull into the interstitial space until the cable marker is even with the top of the riser. Do not cut or remove the tank pull cord.
6. Assemble the cord grip into the riser cap and route the sensor cable through the cord grip.

7. Connect the sensor wires to the field wires in the junction box using the supplied wire nuts.
8. Seal the electrical connections with the epoxy seal packs (*Figure 7* on page 14).

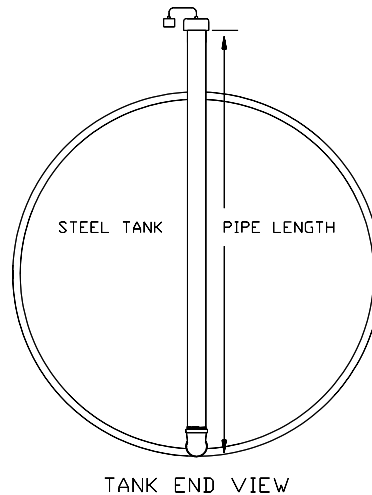

Figure 10: Typical Basic Interstitial Installation in a STEEL Tank

Installation in Steel Tanks

Note

Do not cut sensor wire between sensor and resistor pack.

- *See Figure 10. Measure length of the annular space monitoring pipe from top to bottom and subtract 1/2" (1.3cm) for a total measurement to be used for the sensor placement.*
1. Measure the length from the sensor tip along the sensor cable and mark with tape or marker.
 2. Position the sensor into the monitoring pipe until the tape mark is even with the top of the pipe.
 3. The sensor should not touch the bottom of the monitoring tube to prevent false alarms.
 4. Connect the sensor wires to the field wires in the junction box using the supplied wire nuts.
 5. Seal the electrical connections with the epoxy seal packs.

Q0003-009 Liquid Float Sensor

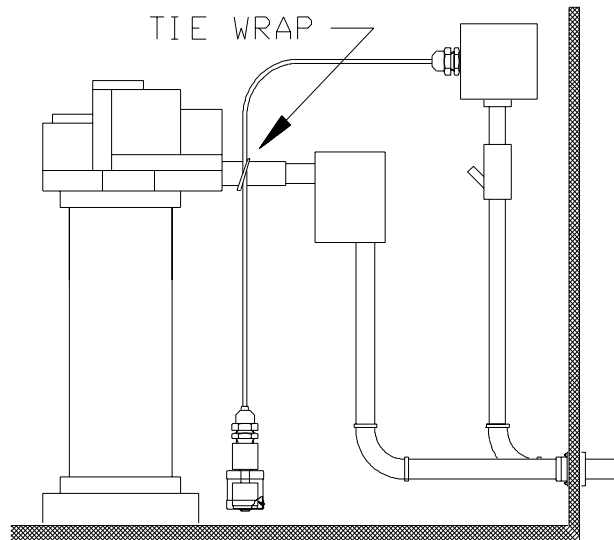

Figure 11: Typical Liquid Float Sensor Installation

Specifications

Primary Use	STP Sumps and Dispenser Pans
Alternate Use	Steel Tank Interstitial
Detects	Liquid
Temp. Range	-40 to 180 °F (-40 to 82 °C)
Dimensions	L = 3.5" (8.9cm) W = 1.43" (3.6cm)
Connections	2 wire (Red / Black – no polarity)

Installation

Figure 11 applies to dispenser pans/sumps, and STP sumps. The STP sump is illustrated but mounting applies to all liquid sensor applications.

1. Check that sump is dry.
2. Position the sensor approximately ½" (1.3cm) above bottom of the sump/pan and secure sensor wire to an existing pipe or bracket with a tie wrap.
3. Connect the sensor wires to the field wires in the junction box using the supplied wire nuts.
4. Seal the electrical connections with the epoxy seal packs (Figure 7 on page 14).

Note

Adjust sensor position for desired detection level.

Q0003-010 Vapor Sensor

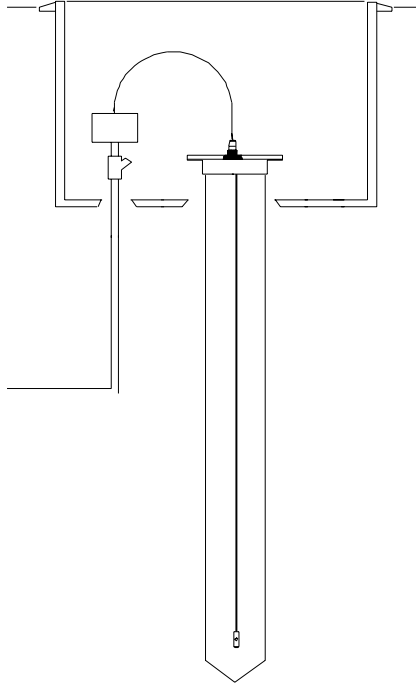

Figure 12: Typical Vapor Sensor Installation

Specifications

Primary Use	Gasoline vapor detection in dry monitoring wells
Detects	Hydrocarbon Vapor
Temp. Range	-20 to 70 °C (-13 to 158 °F)
Dimensions	L = 1" 2.5cm) W =0.5" (1.27cm)
Connections	2 wire (White / Black – no polarity)

Note

Hydrocarbon vapors, heavier than air, settle in low points. Therefore, install vapor sensors as low as possible in monitoring wells for best results.

Do not allow this sensor to be submersed in liquid. Submersion will result in premature sensor failure

Q0003-011/Q0003-012 Dual-Level Float Sensor

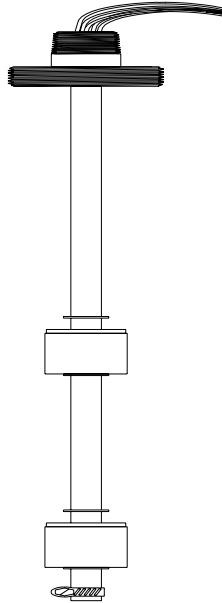

Figure 13: Typical Dual-Level Float Sensor

Specifications

Primary Use	High Product and Overfill Level Alarm in Above-ground Tanks
Alternate Use	Any containment space requiring two different alarm levels
Detects	Liquid
Temp. Range	-40 to 180 °F (-40 to 82 °C)
Dimensions	L = 3.5" (8.9cm) W = 1.43" (3.6cm)
Connections	4-wire (requires 2 channels)

Note

THIS SENSOR HAS NOT BEEN EVALUATED BY UL.

How it Works

- A wire clamp at the lower end is used for attaching an anti-static discharge wire to prevent static buildup on the sensor.
- 2" NPT thread mounting cap with $\frac{3}{4}$ " conduit connector.
- High float switch (yellow wires) is open when dry and closed when wet.
- Low float switch (red wires) is open when dry and closed when wet.

Note

Do not change the position of the floats on probe shaft.

Installation

1. See *Figure 13*. Insert a stranded, non-insulated wire into the clamp at the bottom end of the sensor, and tighten the clamp.
2. Apply fuel-proof, non-hardening pipe sealant to the 2" plug threads. Insert the sensor and anti-static wire into the tank and tighten the plug to prevent loss of fuel.
3. Attach either a conduit connection or a junction box to the $\frac{3}{4}$ " threaded connector on the top of the probe for the wires and wire connections.
4. Pull four wires from the sensor to the console leak sensor interface. Connect the two wires from the sensor's red wires to one sensor input and the two wires from the sensor's yellow wires to a second leak sensor input.
5. Use the wire nuts and epoxy seal packs (*Figure 7* on page 14) provided with the sensor to secure and waterproof the wire connections at the sensor.
6. Program the leak sensor inputs for "normally open" sensors and identify the red wire input as "High Product" and the yellow wire input as "High, High" Product.

Q0003-013 Interstitial Sensor

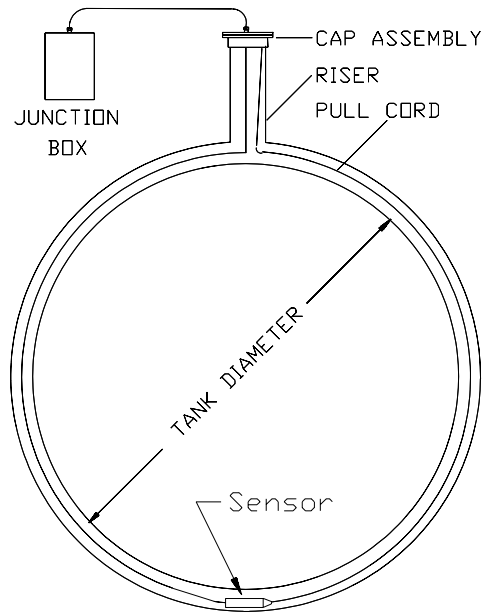

Figure 14: Typical Interstitial Sensor Installation

Specifications

Primary Use	Interstitial Space (fiberglass tanks)
Alternate Use	None
Detects	Liquids
Temp. Range	-4 to 176 °F (-20 to 80 °C)
Dimensions	L = 3" (7.6cm) W = 1.5" (3.8cm) H = 0.38 (1cm)
Connections	2 wire (Red / Black – no polarity)

Installation

1. See Figure 14. Determine tank inside diameter (TD).
2. Measure the riser height (RH) from top of tank to cap assembly.
3. Multiply the tank diameter (TD) x 1.57 and add the riser height (RH).
Formula = (TD) x 1.57 + (RH)
4. Measure the length from the sensor tip along the sensor cable and mark with tape or marker.

5. Attach the tank pull cord to the sensor and pull into the interstitial space until the cable marker is even with the top of the riser. Do not cut or remove the tank pull cord. Position the sensor at the bottom center of the tank.
6. Measure the sensor resistance for less than 1 ohm in the normal position. If the sensor measures “open,” reposition until the “normal” position is indicated by <1 ohm reading.
7. Assemble the cord grip into the riser cap and route the sensor cable through the cord grip.
8. Connect the sensor wires to the field wires in the junction box using the supplied wire nuts.
9. Seal the electrical connections with the epoxy seal packs (*Figure 7* on page 14).

Post-Installation Checklist

The system must be installed in accordance with the instructions in this book. The installation contractor must complete this checklist.

Note

*INSTALLATION CONTRACTOR: Correct all “NO” replies in the following checklist before scheduling the startup contractor to inspect and commission the system. The most common installation problems are listed in **bold italics**.*

Warning

Failure to complete this checklist may cause the site owner or start-up contractor to reject portions of your installation.

1. ♦ Yes ♦ No Some sensors require 3 wires for connection while others require 2 wires. Is the correct number of wires installed for each of the sensors?
2. ♦ Yes ♦ No **Are Epoxy Seal Packs available for sealing all wire connections during startup?**
3. ♦ Yes ♦ No Are conduit Seal-off fittings installed per the installation manual, National Electrical Code, and Local Authorities?
4. ♦ Yes ♦ No **Are all sensor wires, terminating inside the console, labeled with sensor type and location? Example: STP Sump, Tank 2**
5. ♦ Yes ♦ No **Are sumps and dispenser pans dry and free of fuel and water? Any residual fuel in sumps will create a saturated vapor environment that may be detected by the sensors.**
6. ♦ Yes ♦ No Are manhole covers in place and loosely sealed (until startup is completed) to prevent water accumulation in sumps ?
7. ♦ Yes ♦ No **Are intrinsically safe leak sensor wires properly separated from non- intrinsically safe wiring?**
8. ♦ Yes ♦ No Is the console properly labeled with the location of each sensor?

When you can answer all questions “YES”, (where applicable) notify the startup contractor to schedule system inspection and commissioning.

Present a completed form to the startup contractor.

Calibrating the Console

The front panel is shown in *Figure 15* on page 29.

At first power up, all four red sensor STATUS lamps (1, 2, 3, 4) and the green POWER lamp flash simultaneously once per second. This means the system is not calibrated.

Calibration is required before you can operate the system.

To calibrate, all sensors must be wired to the unit and in a normal (non-alarm) state. Calibration is easiest before you install the sensors in their monitoring spaces.

1. Turn the keyswitch a quarter-turn clockwise. The green POWER lamp stops flashing and glows continuously.
2. Hold down **Press to Silence** for at least 5 seconds. After five seconds the unit detects the sensors and stores the configuration. The buzzer sounds briefly when configuration is successfully stored.
3. Turn the keyswitch a quarter-turn counterclockwise, back to the RUN position. The green POWER lamp will begin blinking every second - this tells you the unit is in normal mode.
4. Activate each sensor individually to insure that the sensors and console are functioning properly and will detect alarm conditions.
 - You can calibrate at any time. You should calibrate after installing any new sensors or probes.
 - See *In Case of Problems* on page 31 if your system does not respond properly.

Note

The Leak Sensor Plus assumes that the current state of the sensors at the time of calibration is NORMAL. Make sure all sensors are in their NORMAL state prior to performing a calibration. This may require removing the sensors from their monitoring spaces during the calibration period.

Operation

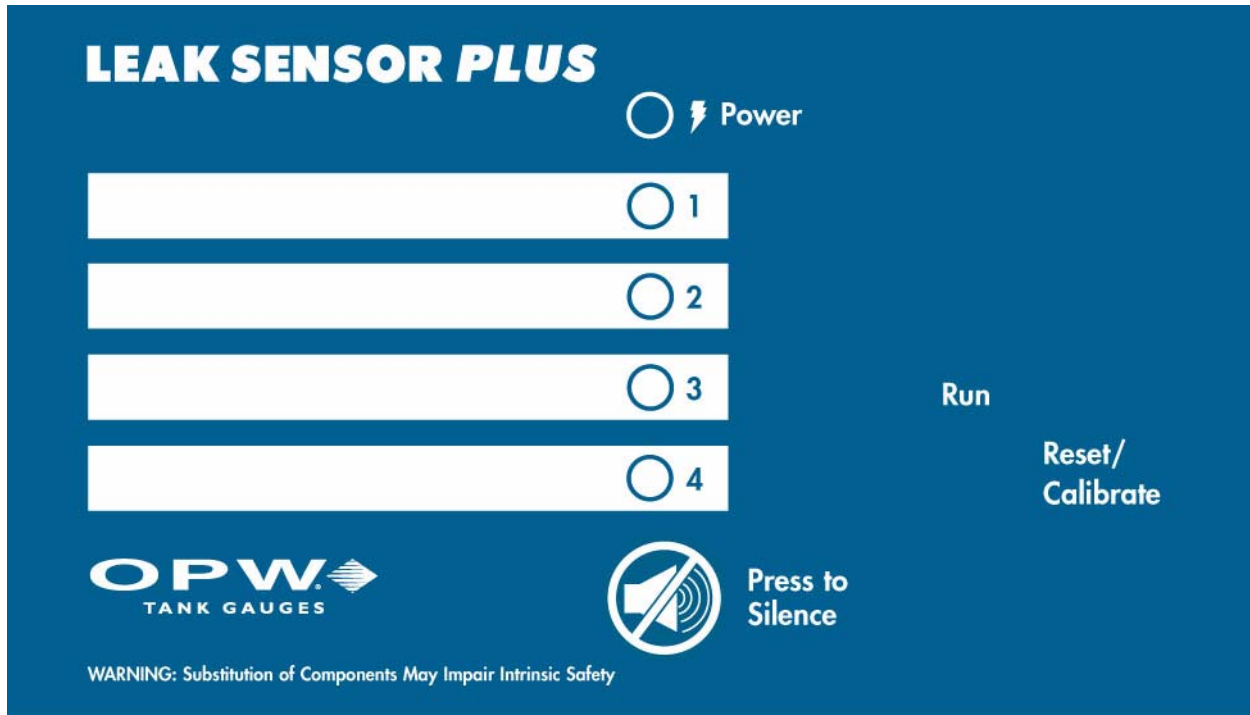

Figure 15: Leak Sensor Plus Front Panel

LED Indicators

Figure 15 is an overview of the controls and indicators on your Leak Sensor Plus.

Inspect the front panel periodically to assure proper operation. Normal operation is a slowly blinking green POWER light, with all red ALARM lights off.

If no lamps are illuminated or a red alarm lamp is ON, notify whomever is responsible at your site immediately.

The Leak Sensor Plus also checks for short circuits and open circuits (missing sensors). The short or open condition must exist for five seconds to be indicated.

See *Table 4* for alarm and fault conditions.

Table 4: Console Lamp Indications

Indication	What Does It Mean
Red sensor STATUS lamps OFF, green POWER lamp flashing slowly	Normal operation
Steadily flashing red STATUS lamp	Alarm condition
Double flashing of red STATUS lamp, short space between flashes	Short-circuit
Triple flashing of red STATUS lamp, with short space between flashes.	Open circuit (typically, a sensor is missing)

When a new alarm is detected, the STATUS LED for that sensor flashes as described in *Table 4*, the internal audible alarm sounds, and the external relay contacts close.

Silencing Alarms

To silence the alarm, press **ALARM SILENCE**.

Because the relay contacts work with the alarm, pressing **ALARM SILENCE** also opens the relay contacts. The STATUS LED remains ON after you silence the alarm. To turn the LED OFF, reset the system with the key.

Resetting the System

Turn the key switch to clear all alarms and return the unit to normal operation. Turn the switch one-quarter turn clockwise for about a second and then back again.

Do not leave the unit in the RESET state, indicated by the green LED ON constantly.

Note

The condition that caused the alarm must, obviously, be removed in order for the system to reset. If the alarm condition persists after the system is reset, there is still a problem in that sensor's area.

In Case of Problems

SYMPTOM	POSSIBLE CAUSE(S)	REQUIRED ACTION(S)
System does not operate. Normal operation LED is OFF	<ul style="list-style-type: none"> • Circuit breaker is turned off. • Fuse (F1) is blown. • Component failure on Power Supply board. • Component failure on Processor board. 	<ul style="list-style-type: none"> • Turn on circuit breaker. • Replace fuse. Use only 50 mA Fast-Blow. • Replace Power Supply board. • Replace Processor board.
Normal operation LED is On steady	<ul style="list-style-type: none"> • Reset / calibration key left in ON position. • Processor locked up. 	<ul style="list-style-type: none"> • Turn key back to normal position. • Replace Processor board.
Sensor Status LED flashing	<ul style="list-style-type: none"> • Leak detected. • Discriminating sensor contaminated. 	<ul style="list-style-type: none"> • Find and correct cause of leak. • Clean sensor as needed to clear alarm condition. • Clean sensor as needed to clear alarm condition. <p>NOTE: A high concentration of vapors can cause a discriminating sensor to indicate an alarm condition. All residual fuel and vapors must be removed and cleaned before reinstalling the sensor.</p>
Sensor Status LED triple-flashing	<ul style="list-style-type: none"> • Short circuit in sensor wiring detected. • Wiring connections in junction box wet because they weren't sealed properly with the epoxy pack. 	<ul style="list-style-type: none"> • Find and correct cause of short circuit. • Dry and rework connections and seal with epoxy pack.
Sensor Status LED double-flashing	<ul style="list-style-type: none"> • Open circuit in sensor wiring detected. • Wiring connections corroded or broken because they weren't sealed properly with the epoxy pack. 	<ul style="list-style-type: none"> • Find and correct cause of open circuit. If sensor has been permanently removed from system, recalibrate system to clear condition. • Clean and rework the connections and seal with epoxy pack.

Index

A

AST, 3

B

Basic interstitial sensor, 16

C

Calibration, 8
Class I, Group D, 2
Codes, 3
Color Codes, 13
Conduit, 5
Containment pans, 12

D

Dual-level Float sensor, 20

E

European considerations, 12

F

Features & Benefits, 3
Front panel features, 29

H

Hydrostatic interstitial sensor,
15

I

Installation
 Console, 5
Interstitial spaces, 12
Intrinsically safe, 2

L

LEDs, 29
Liquid float sensor, 18

M

Monitoring well, 12
Mounting Dimensions, 7
Mounting hardware, 6
Mounting Locations, 4

N

National Electrical Code, 2
Normal operation, 29

O

Open circuits, 29
Operation, 29

P

Post-installation checklist, 25
Power Requirements, 4
Press to Silence button, 27
PVC, 5

S

Seal Packs, 14
Seal-Off Fittings, 5
Sensors
 Basic interstitial, 16
 Dual-Level float, 20
 Hydrostatic interstitial, 15
 Installing, 11
 Interstitial, general, 22
 Liquid float, 18
 List of available, 4
 Vapor, 19
 Wiring, 12
Short circuits, 29
Specifications
 Console, 4
Standards, 3

T

Temperature Range, 4
Troubleshooting, 31

U

Underwriters Laboratories, 4
United States Requirements,
2
UST, 3

V

Vapor sensor, 19

W

Warnings, 1



OPW Fuel Management Systems
6900 Santa Fe Drive
Hodgkins, IL 60525
708-485-4200