

# HH 24" Pressure/Vacuum Tank Hatch

05-31-002DS

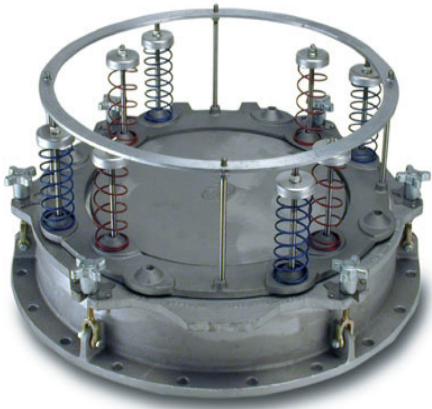

## Applications:

- Silos
- Grain Elevators
- Baghouses

## Markets:

- Cement
- Food Products
- Grains
- Industrial Products

## Features:

- Large 24" opening provides higher venting capacity and improved access into the tank
- Palm nuts allow for quick and easy opening
- Available with various pressure and vacuum settings
- All aluminum contact parts; NO RUST!!
- Standard FDA approved gasket
- No internal hardware to contaminate product
- Weather hood provides weather protection
- Base bolts directly to the tank

## HH Series Ordering Specifications

Model	PRESSURE SETTING	VACUUM SETTING	GASKET	
HH	(Ounces/square inch)	(Ounces/square inch)	#	MATERIAL
	Settings: 02 to 29	Settings: 0.5 to 9.0	1	White Food Grade
	Increments of 2	Increments of 0.5		
	Indicate Pressure Setting Utilizing first 2 digits	Indicate Vacuum Setting Utilizing second 2 digits		Last Digit

Example: HH02051 (Model HH, Pressure Setting 02 oz., Vacuum Setting 0.5 oz., Gasket 1 - White Buna)

Warning: Cover should be inspected at least once a month for proper operation and proper functioning hardware. The weather hood should be inspected for damage. If items are missing or damaged they should be replaced.

NOTE: Pressure and Vacuum settings are factory set, do not attempt to change or alter settings. Relieve all pressure and vacuum before attempting to open the cover.

## Specifications

- **Product/Part Numbers:** See Ordering Specifications Chart
- **Dimensions:** Overall Height 13" (Approximately)
- **Weight:** 81 lbs.

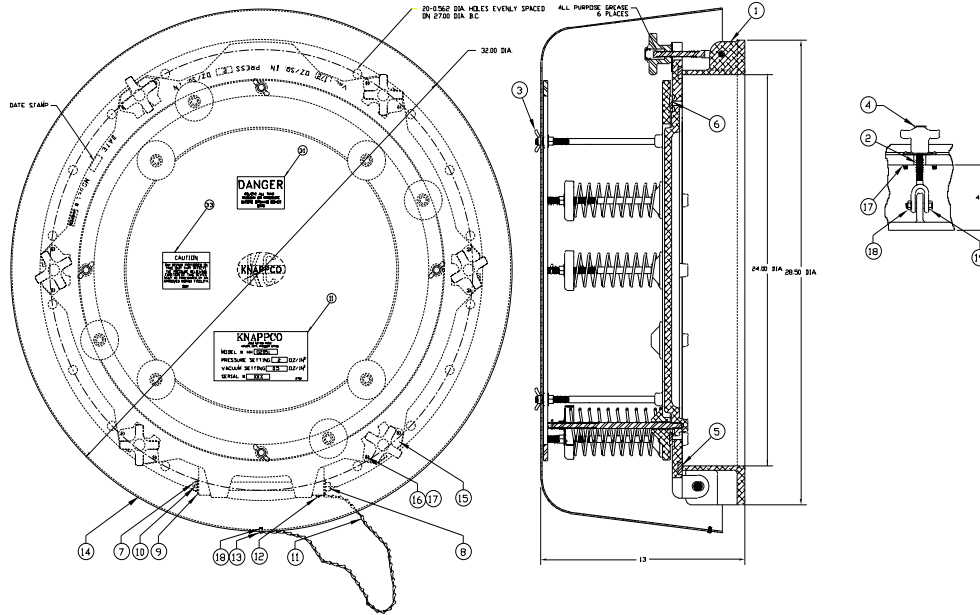

## HH 24" Pressure/Vacuum Tank Hatch

ITEM	DESCRIPTION		ALUMINUM	PLATED	SS304	OTHER
1	Base Ring	1	5709			
2	Hand Knob Assy.	6		5146		
3	Wing Nut	4		5695		
4	Plug Button	6		5719		
5	Cover Gasket	1				5722
6	Poppet Gasket	1				5723
7	Hinge Pin	1		5724		
8	Pal Nut	1		1020		
9	Washer	1		1043		
10	Cotter Pin	1		1045		
11	Chain	1		3589		
12	Screw	1		1375		
13	Screw	1		2716		
14	Weather Hood	1	5699			
15	Wear Plate	6			2592	
16	Screw 10-32 x 1-1/8"	12			3546	
17	Lock Nut	13			3544	
18	Nut, Hex, 5/16-24	6				H06151M
19	Screw, 5/16-24 x 1-1/2"	6				H03114M