

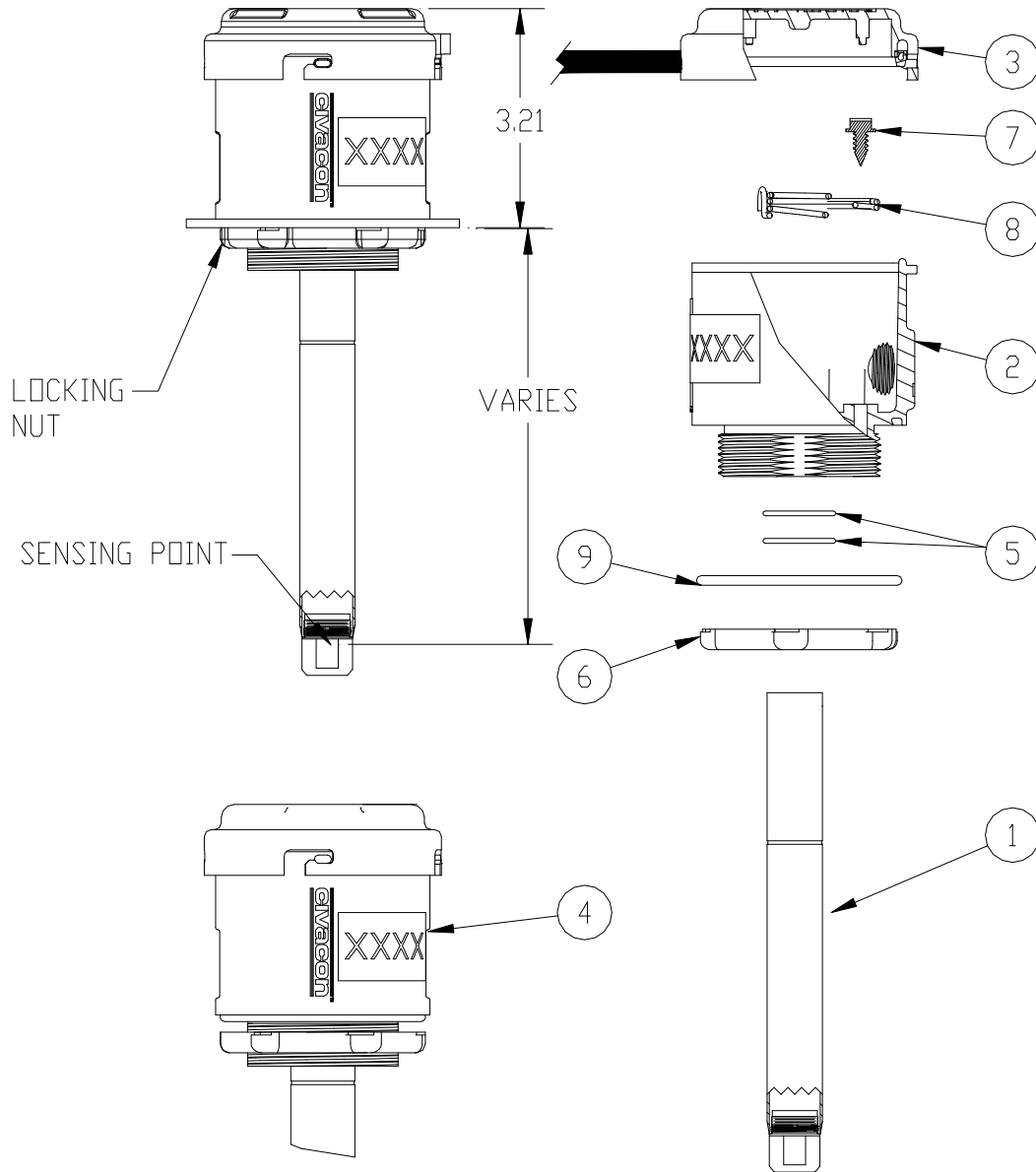

1554 Series Optic Sensor (2-Wire)



PARTS BREAK DOWN

ITEM	PART NUMBER	DESCRIPTION	QTY.
1	STK-XXXB	OVERFILL PROBE TUBE	1
2	H52841	HOUSING BODY	1
3	1356-2W	CAP 2-WIRE OPTIC SENSOR	1
4	H52301M-1554	LABEL	1
5	H52842M	O-RING, BUNA-N	2
6	H52477M	LOCK NUT	1
7	H52898M	SCREW	1

ITEM	PART NUMBER	DESCRIPTION	QTY.
8	H52845M	SPRING	1
9	H52844M	O-RING, VITON	1

REPAIR KITS	
H52841-NPT	HOUSING ASSEMBLY

** ALL ITEMS INCLUDED IN H52841-NPT EXCEPT ITEMS 1, 3, & 4