



## Series 300 Air Interlock Valves

Rev. A, Nov. 2010

### Air Interlock Valve

Civacon's New Model 300 Series Air Interlock Valve is the perfect solution for all your petroleum transport interlock needs. From drive-off protection on APIs and Vapor Adaptors, to interlocking guard bars and cabinet doors, our Model 300 Air Interlock Valve fits right in. The Model 300 valve is a drop-in, replacement for our earlier models and for competitive brands. The fit and function remain identical to previous models.

Their new durable yet lightweight hard-coat anodized aluminum body, stainless steel internals and hardware deliver extreme durability, extended life and provide superior protection from chemicals and the elements. This completely new design uses industry standard Parker Brand™, premium AS568B standard O-rings. Our valve features a unique and innovative "closed loop breather" design that requires no vent hole in the rear end cap. This provides a completely sealed design that won't "breath in" moisture or contamination while in use. Maintenance requirements have been minimized for long, trouble-free operation.



Model 300 Shown

### Features:

- Premium Parker Brand™ Standard Series-2 O-Rings for Ease of Maintenance
- Stainless Steel Shaft and Hardware for Trouble Free Performance.
- Solid One - Piece Extruded Aluminum is Lightweight Yet Strong
- Hard Coat Anodized Body for Extreme Durability and Wear Resistance
- Closed Loop Breather Keeps Contamination Out for Reduced Maintenance
- Rear End Cap is Completely Sealed. No Vent Holes are Required.

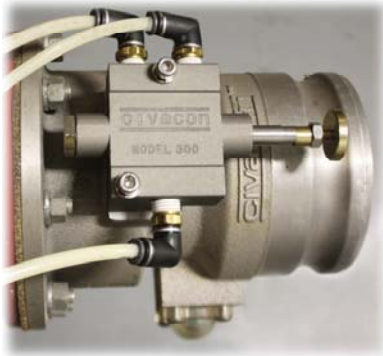

### Available Models:

**Model 300** Air Interlock With Round Push Button

**Model 301** Air Interlock with Elongated Push Plate

#### Maintenance Kits

**300RK** - Rebuild Kit for Model 300 or 301 (Seals, Shaft & Spring)

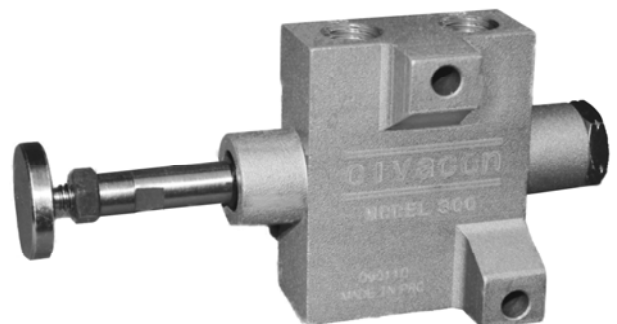

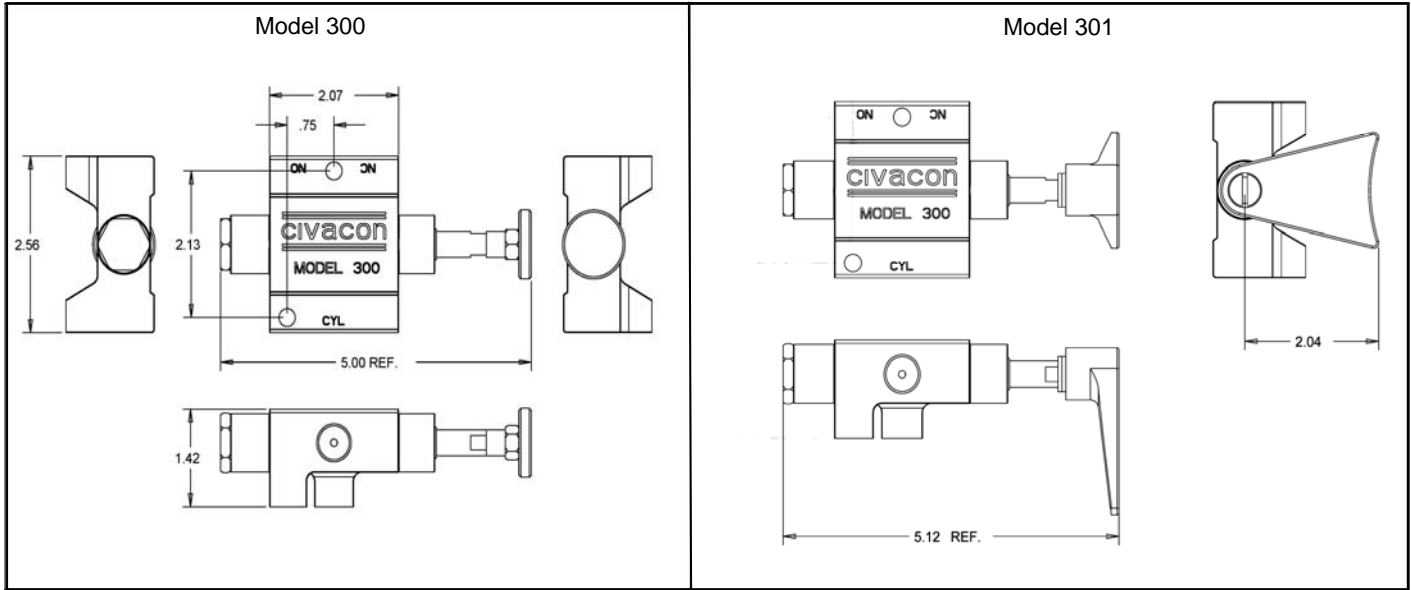

### Product Specifications

**Product Part Numbers:** 300 & 301

**Materials:** Hard-Coat Anodized Aluminum, Stainless Steel and Premium Low Swell Buna N

**Dimensions:** Height 1.42" (3.61 cm) / Width 2.56" (6.5 cm) / Length (See Drawing Above)

**Weight:** 10.5 Oz (.30 kg)      **Temp Range:** - 40° to +158° (-40 to +70 C)

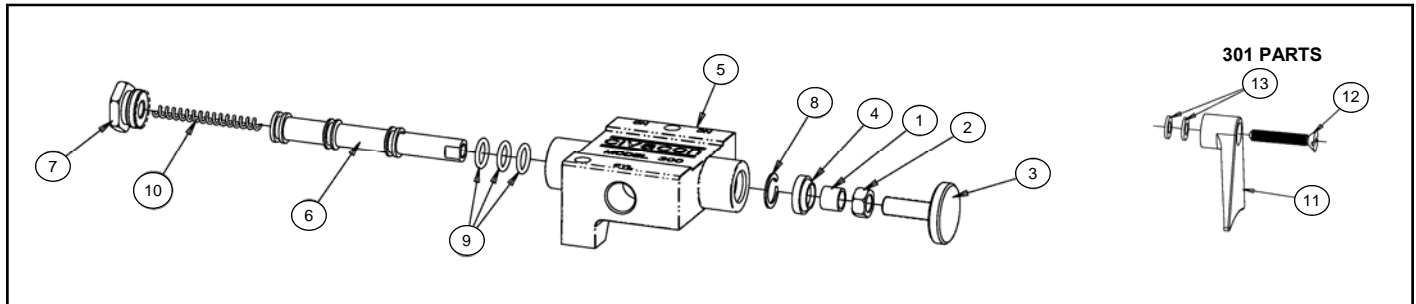

Item	Part #	Qty	Description	Item	Part #	Qty	Description
1	200 - 5	1	Brass Spacer Sleeve	8	12199	1	Spiral Retaining Ring
2	200 - 6	1	Hex Nut , 1/4 x 20 SS	9	H20506M	3	O - Ring Size 2-012 Buna N (Parker)
3	H20488M	1	Stem Adjuster	10	H20507M	1	Spring
4	12159	1	Wiper Seal	<b>Model 301 Parts Shown Below</b>			
5	12165	1	Body	11	11393	1	Push Plate
6	12167	1	Stainless Steel Shaft	12	12013	1	Screw FLHD 1/4 x 20 x 1 1/2 LG 18-8 SS
7	12168	1	Rear End Cap / Spring Retainer	13	H20312M	2	Flat Washer

