



Air Interlock Valve Model 200 and 201

Safety from accidental drive-aways is guaranteed when using the Air Interlock Valve

The Model 200 and 201 air interlock valves are installed on bottom loading adaptors and vapor recovery fittings to lock the brakes to prevent drive-aways during loading. This pneumatic valve can be used in a number of different applications for additional safety features.



Air Interlock Valve Model 201



Vapor Recovery Adaptor with Air Interlock Valve Model 201



Air Interlock Valve Model 200



Features and Benefits

- Corrosion resistant nickel-plated aluminum body
- Main shaft wiper seal will prevent contaminants from entering seal area
- Compact design fits in all air valve locations
- Universal mounting fits all current API adaptors and vapor fittings
- Rigid mounting for extended valve life

Air Interlock Valve Model 200

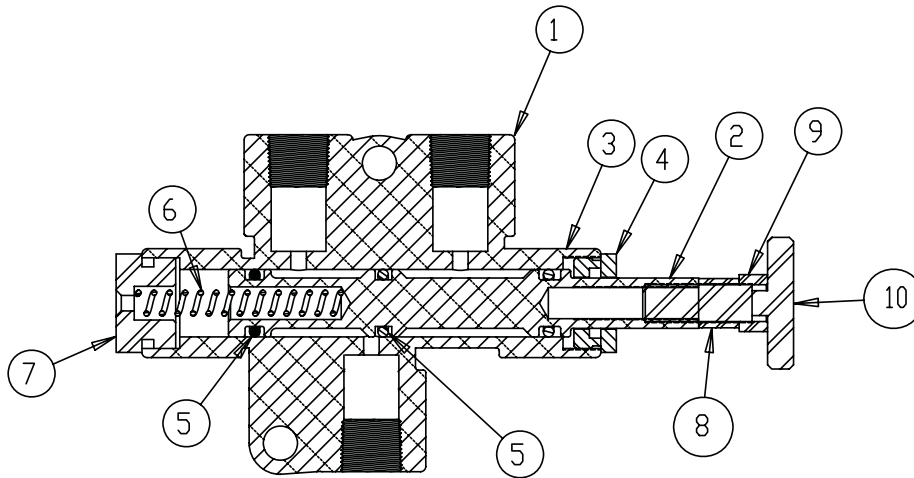

Air Interlock Valve Model 201

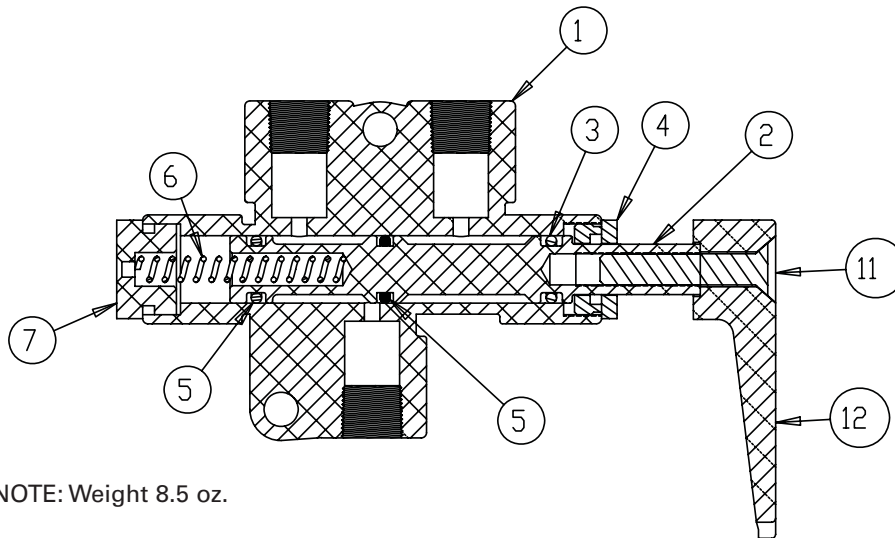

NOTE: Weight 8.5 oz.

Air Interlock Valve: 200 Model and 201 Model

| ITEM | PART NUMBER | PART DESCRIPTION |
|------|-------------|---------------------------|
| 1 | 2001-1 | BODY (1) |
| 2 | 200-2 | SHAFT (1) |
| 3 | 200-3 | O-RING (1) |
| 4 | 200-4 | NUT GLAND (1) |
| 5 | 200-8 | O-RING (2) |
| 6 | 200-9 | SPRING, AIR INTERLOCK (1) |

| ITEM | PART NUMBER | PART DESCRIPTION |
|------|-------------|---------------------|
| 7 | 200-10 | NUT, END (1) |
| 8 | 200-5 | SPACER (1) |
| 9 | 200-6 | HEX NUT (1) |
| 10 | 200-7 | ADJUSTER (1) |
| 11 | 11374 | FLAT HEAD SCREW (1) |
| 12 | 11393 | PUSH PLATE (1) |