

OPW Swing Check Valve

The OPW Swing Check Valves are designed to allow one-way product flow in fuel supply lines. OPW Swing Check Valves are installed in-line on fuel supply or transfer piping. A free-swinging poppet in the valve opens with flow of product and closes to prevent back-flow. The swing check valves can be located in either horizontal or vertical piping. The 175 is available in 2" female NPT connections. The 175B is similar to the 175 except it has an internal pressure relief valve to help absorb thermal expansion in the fuel supply or transfer line, pressure relief set at approx. 25 psi (1.7 bar). The 1175 is available in 3" female NPT connections.

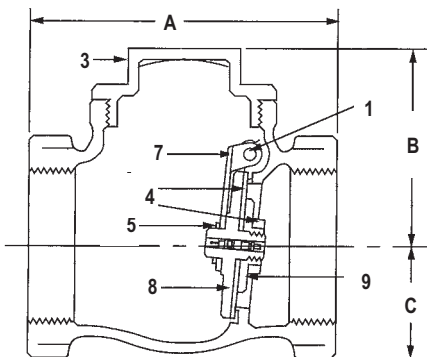

Dimensions

	in.	mm
A	7½	191
B	7 ⁷ / ₁₆	183
C	2 ¹⁹ / ₃₂	66

Materials

Body: Bronze
Seat Ring: Brass
Disc: Viton®
Cap: Bronze

Swing Check Valve



Features

- ◆ **Viton Main Disc** - compatible with gasoline, diesel, kerosene, ethanol, methanol, MTBE, fuel oil, mogas, motor oil and various other blends of fuel.
- ◆ **Full-Bore Inside Diameter for Superior Flow Rates** – maximizes flow rates in the fuel supply lines.
- ◆ **Easy Service Entry** – threaded cap assembly allows removal, replacement or servicing of the carrier, disc or disc holder.
- ◆ **Rated Normal Pressure Limit: 125 psi (8.6 bar)**
- ◆ **Cold Non-Shock Pressure Limit: 200 psi (13.8 bar)**
- ◆ **Temperature Limit: 225° F**

Ordering Specifications

Product #	in.	mm	lbs.	kg
175-0044	2	51	4.7	2.14
175B-1544	2	51	4.6	2.10
1175-0050	3	76	16.8	7.60

Replacement Parts

OPW 175, 175B, 1175

Key	Part #	Description
1 (175,175B)	H00409RB	Pin
1 (1175)	H06797RB	Stem
2 (175,175B)	H00404RB	Plug
2 (1175)	H06798RB	Plug
3 (175,175B)	H00642B	Cap
3 (1175)	H06800B	Cap
4 (175,175B)	H12071R	Disc
4 (1175)	H06799	Disc Sub-Assy.
5 (175, 175B)	H04035M	Disc Nut
6 (175)	H07488A	Disc Holder
6 (175B)	H07495A	Disc Holder
7 (175, 175B)	H07610RB	Carrier
7 (1175)	H06796B	Carrier
8 (175, 175B)	H05792M	Retaining Ring
9 (175, 175B)	H03295M	Washer
10 (1175)	H04250M	Lock Nut