

HH Pressure/Vacuum Tank Hatch

24" Tank Hatch Maintenance Manual

Technical Bulletin 6-94
Rev A, 05/12/05

4304 Mattox Road, Kansas City, MO 64150
Phone: 816-741-6600 Fax: 816-741-1061
Technical Hotline: 800-5-CIVACON
Customer Service: 888-526-5657
www.civacon.com



Product Description

The Knappco 24" pressure/vacuum tank hatch is designed for use on storage bins and silos that require large volume pressure and vacuum relief or that require a 24" access port.

Maintenance Schedule

The Knappco 24" pressure/vacuum tank hatch must be inspected at least once per month. However, in severe applications, (Corrosive environments, environments with heavy product buildup, etc.) the number of inspections should be increased to 2 to 4 per month depending on the application.

NOTE: This tank hatch must be maintained on a regular basis to insure proper operation.

Inspection Procedure

WARNING: All internal tank pressure (pressure & Vacuum) must be relieved prior to servicing.

1. Review Figure 1 and Figure 2 before starting inspection.
2. Remove weatherhood (#24).
3. Remove product build-up and dust from the tank hatch.
4. Visually inspect pressure/vacuum springs (#25 & #26) and pressure/vacuum studs (#6 & #7) for corrosion and bending. Also, check the hardware to make sure that none of the fasteners have backed off due to vibration. Likewise, insure that the cotter pins (#20) are secured to the vacuum studs (#7).

NOTE: Spring settings are preset at the factory. If you have any spring related concerns or problems, contact your distributor or Knappco directly.

5. Push down on the vacuum poppet (#2) to ensure free operation.
6. While holding vacuum poppet (#2) open, visually inspect the pressure/vacuum poppet gasket (#16) surface. If the gasket surface has been cut or if pieces are missing. It should be replaced.
7. Unscrew hand knobs (#10), and open the main cover (#3).

NOTE: If the hand knobs become difficult to turn, grease can be put inside the cavity under the plug button on the hand knob.

8. Push on the underside of the vacuum poppet (#2) to ensure the free operation of the pressure poppet (#1).

NOTE: If you discover binding when you test the vacuum or pressure poppets, do not put grease or any other liquid lubricant on the studs. This will attract dust, which will hamper the operation of this vent.

9. Inspect the main cover gasket (#15) for cuts and abrasions. If this gasket has taken a permanent set of 1/16" or greater, it should be replaced.
10. Close the main cover (#3) and reassemble the vent.

Fig. 1: Tank Hatch Assembly

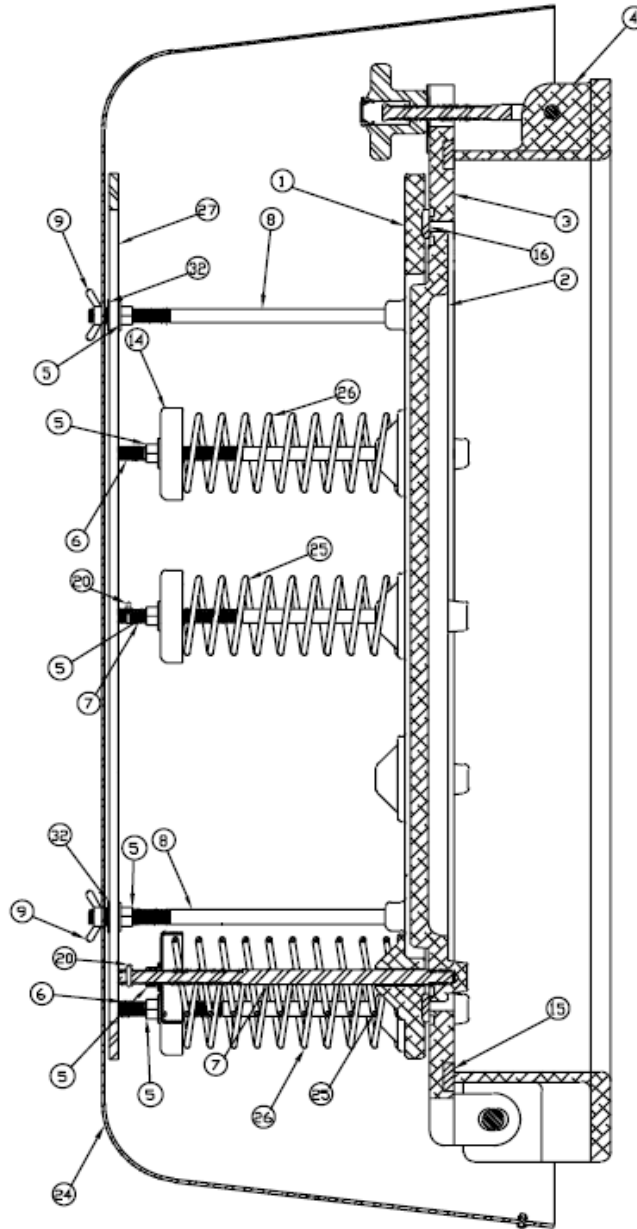

Fig. 2: Hand Knob Assembly

