

OPW 68EZR 3/4" Dry Reconnectable Breakaway

The OPW 68EZR Reconnectable Breakaway has been designed for retail fueling operations to deliver an increased level of security in the event of a drive off. Not only is it the fastest and easiest breakaway in the industry to reconnect, but also the one that delivers the greatest peace of mind that it is securely reconnected. Built on the 66REC breakaway technology platform, the 68EZR delivers trusted OPW quality and proven technology at the lowest cost of ownership. The 68EZR is installed on fuel dispensing hoses and will separate when subjected to a designated pull force. Upon separation, the dual valves seat automatically, stopping the flow of fuel and limiting any fuel spillage, while protecting the dispensing equipment. For proper operation on high-hanging hoses, the OPW 68EZR 3/4" must always be installed with a "straightening" hose with a minimum length of 9", such as the OPW 66H. For low hose applications, the OPW 68EZR should be installed downstream of the retractor cable.

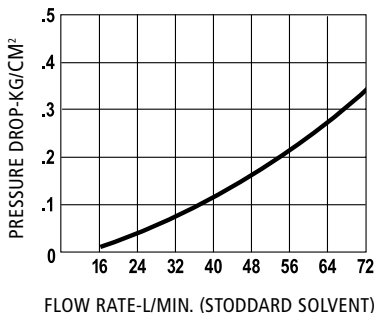
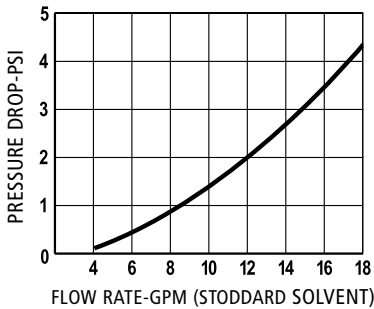

Materials

- Body:** Die-cast zinc, Zamak
- Protective Sleeves:** Zytel
- Main Seals:** Viton®
- Main Spring:** Stainless steel
- Guide and Poppets:** Acetal / Delrin
- Packed:** 20 per Case



Features

- ◆ UL and ULC listed for use in gasoline, ethanol blends up to 25% (E25), diesel, and biodiesel blends up to 20% (B20). Specific listings available at www.opwglobal.com.
- ◆ Pull Force – the 68EZR will break away with a pull force of no more than 350 lbs.
- ◆ Unique Double-Poppet Design – features low pressure drop.
- ◆ Coupling Halves – protected by proven plastic sleeves.
- ◆ Easily Reconnected – features "Push-Twist-Click" technology; simply realign the valve, push in and then twist until you hear the audible click.
- ◆ Cold weather compatible
- ◆ Reconnection force of approximately 7 lbs.
- ◆ Line Shock – the OPW 68EZR is able to absorb the effects of normal line shock through the unique design of the disconnecting features.
- ◆ 50 psi (3.45 bar) maximum allowable operating pressure.

Ordering Specifications

Product #	Size	mm	Weight	
			lbs.	kg
68EZR-7575	3/4" (NPT)	19	1.2	0.54
68EZR-75RF*	3/4" (NPT)	19	1.2	0.54

*68EZR-75RF is UL and ULC listed for use in gasoline, ethanol blends up to 25% (E25), diesel, and biodiesel blends up to 20% (B20).

Replacement Parts

Part #	Description
211143	Main Seal

68EZR Series Instruction Sheet Order Number: **208080**

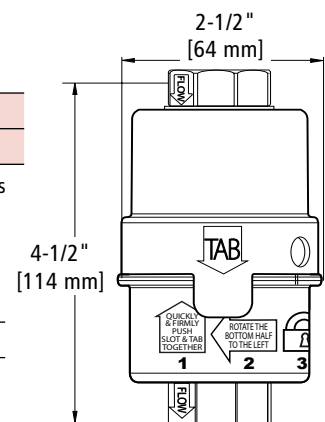

Listings and
Certifications

