

Enhanced Vacuum Relief Valves A-210 to A-212 Protect Against Excess Vacuum in Tank Cars

Designed to allow atmospheric air enter the tank car and protect it from collapse when there is a vacuum in the tank car.

Enhanced Valve Design

Midland Vacuum Relief Valves are designed with a philosophy to keep the debris out of the tank, relieve vacuum pressure in the tank and avoid the Non-Accident Release (NAR) of the commodity by keeping it safely secured inside the tank.

The operation of Midland's Vacuum Relief Valves are optimized for the rough handling commonly associated with Crude, Ethanol and other harsh commodities.



Stainless-Steel Mesh Screen Filter

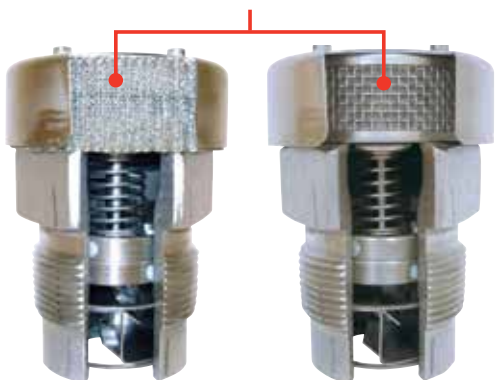

Basic or Optional Premium Filter

Inlet filter prevents debris from entering the seating area, which can occur when cars are improperly vented during unloading.

Stainless-Steel Baffle

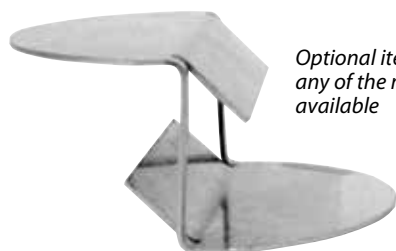

Optional item for any of the models available

Features

- Enhanced VRVs eliminate NARs during transport and transfer process
- Optimized for transportation of harsh commodities – including ethanol and crude
- Stainless-steel construction for better corrosion resistance
- No-step design eliminates improper cycling of the valve
- Built-in debris screen keeps contamination from entering the valve-seating area
- Unique seal design eliminates the possibility of using incorrect materials or performing improper installation
 - Seal location helps eliminate “blow outs”
- The poppet on the valve has been reversed, moving the sealing surface away from the lading
- An optional baffle keeps the lading from the sealing surface during product surges
- The stem is guided in two places
 - This reduces accidental cycling or “burping” of the valve
 - Gives the valve a more consistent seal and decreases the risk of pressure leaks
- Pressure settings from ¾ psi to 5 psig of vacuum

A-210 to A-212 Vacuum Relief Valve

Vacuum Relief Valve Part System

Style		Configuration		Pressure Setting (psi)	**Seal Material	
A-21X		-FRXX		-XX	-XX	
*2.5" NPT Threaded	0	Basic Screen w/ baffle	1	(null = 0.75)	Buna N	BN
2.5" Flanged	2	Basic Screen, No Baffle	10	2	Buna N, Food Grade	BNFG
		Premium Screen w/ Baffle	2	3	Ethylene Propylene	EP
		Premium Screen, No Baffle	20	4	Ethylene Propylene Food Grade	EPFG
				5	Viton A	VA
					Viton B	VB
					Viton GL	VL
					Chemraz 505	CZ-505

REMEMBER!
 To assure intended operation of Midland Vacuum Relief Valves, AAR recommended methods for safe loading and unloading should be followed.
 (AAR Pamphlet 34, CPC-1245)

***NOTE:** Per AAR regulations, effective July 1, 2013 "threaded connection" VRV's are no longer allowed for OEM use on new tank cars.

****NOTE:** Contact Midland for other seal material options.

Cross Reference - Existing Midland VRV's to Enhanced VRV

Product Family		
CONNECTION	EXISTING	SPECIFY ENHANCED
2-1/2" NPT	A-205	A-210
	A-207	
	A-208	
	A-209	
Flanged - 4x 5/8" dia. Holes on 3-7/8" dia. Bolt circle	A-220	A-212
	A-222	

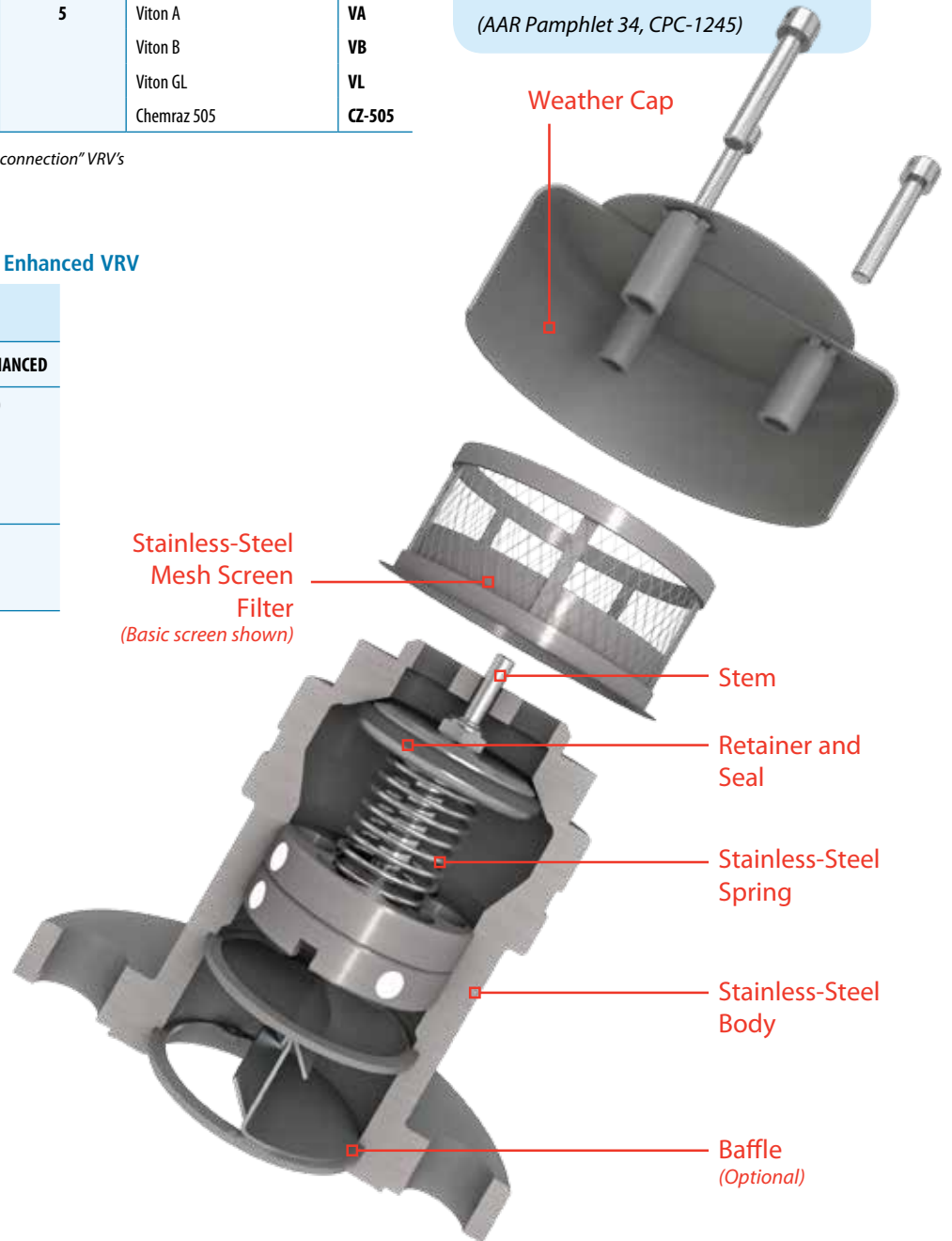

Learn more about stopping NARs. Go to midlandmfg.com and follow the link to <http://nar.aar.com>