

ITEM NO.	QTY.	PART NAME	PART NO.	MATERIAL
1	2	HINGE BOLT	307-1-CS	STEEL
2	2	BUSHING	303-2-CS	STEEL
3	1	SPRING R.H.	303-3-CS	STEEL
4	4	WASHER	303-4-CS	STEEL
5	2	NUT	303-5-CS	STEEL
6	1	SPRING L.H.	303-33-CS	STEEL

NOTES:

1. Use form 304-35 for lifter assister application data.

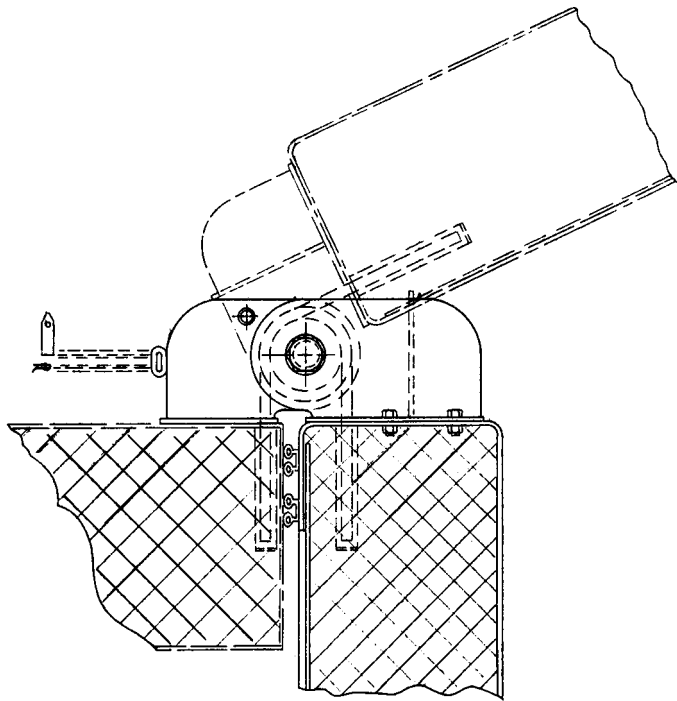

TOP PARTIAL VIEW

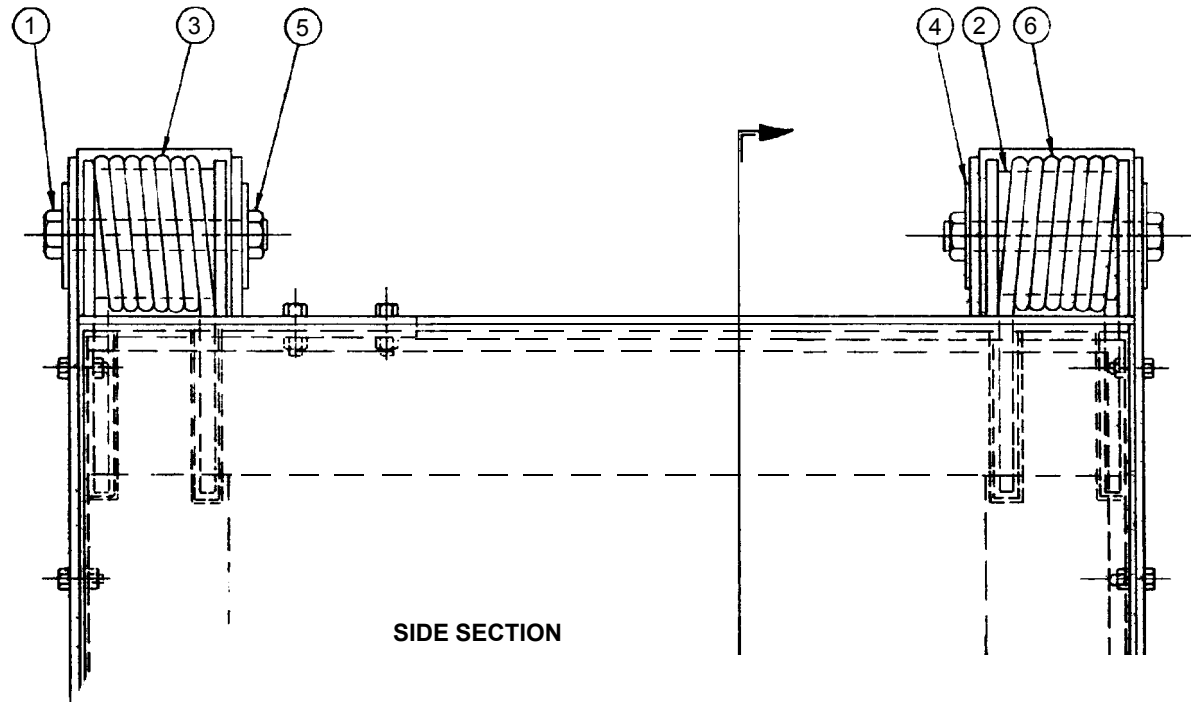

SIDE SECTION