

# K800™ Fuel Site Controller

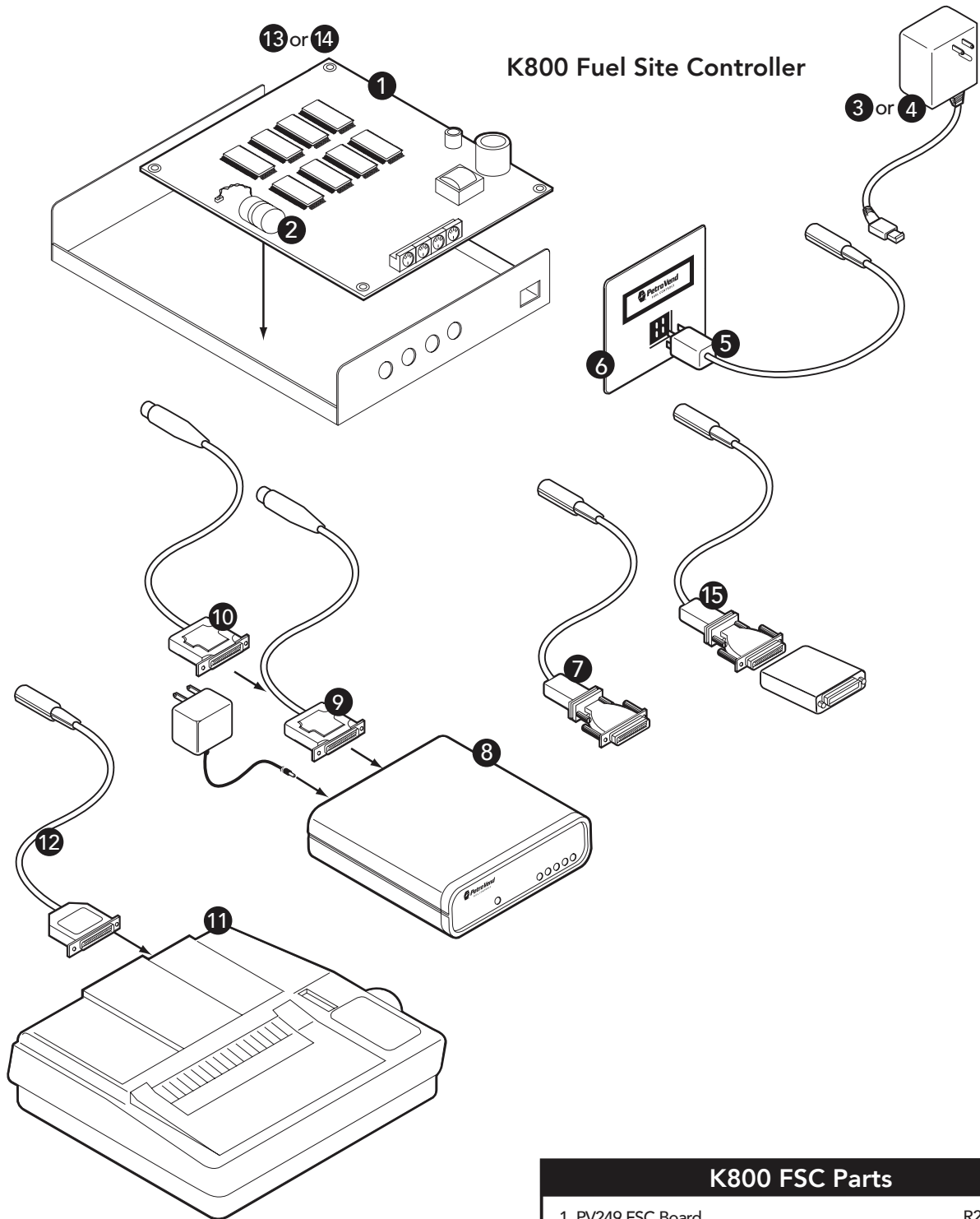

K800 Fuel Site Controller

## K800 FSC Parts

1. PV249 FSC Board.....	R20-0249
2. Fuel Site Controller (FSC) Battery.....	20-5025
3. 120V A.C. Fuel Site Controller Transformer.....	07-0035
4. 240V A.C. Fuel Site Controller Transformer.....	07-0036
5. Petro-Net™ Cable.....	20-1443
6. RS-422 Junction Box Cover.....	20-8035
7. PC/CRT Cable.....	20-1478
8. 1200/2400 Baud External Modem.....	20-8048
9. Modem Cable.....	20-1445
10. Direct Connect Phoenix Cable.....	20-1449
11. Office Journal Printer.....	20-7048
12. Printer Cable (PV249 Fuel Site Controller Boards).....	20-1512
13. K800 Standard FSC Software.....	S08101
14. K800 Standard FSC Software (Spanish).....	S08104
15. 10 Base-T Adaptor.....	20-7081

# K800™ FIT

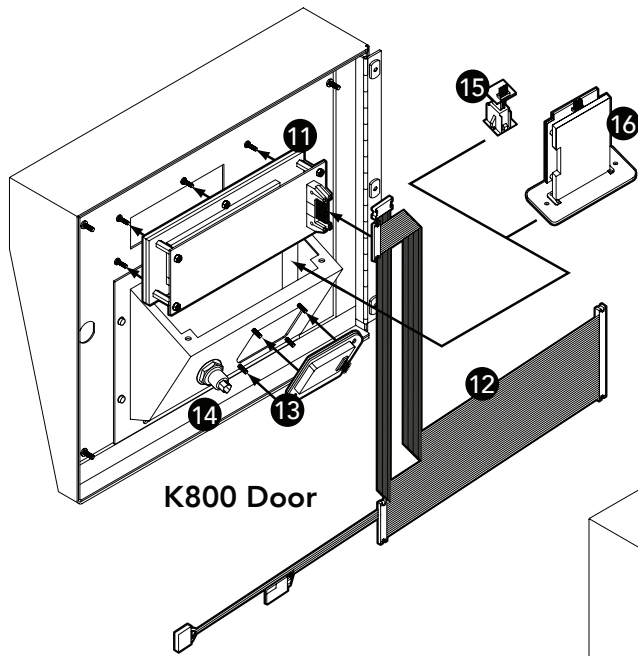

K800 Door

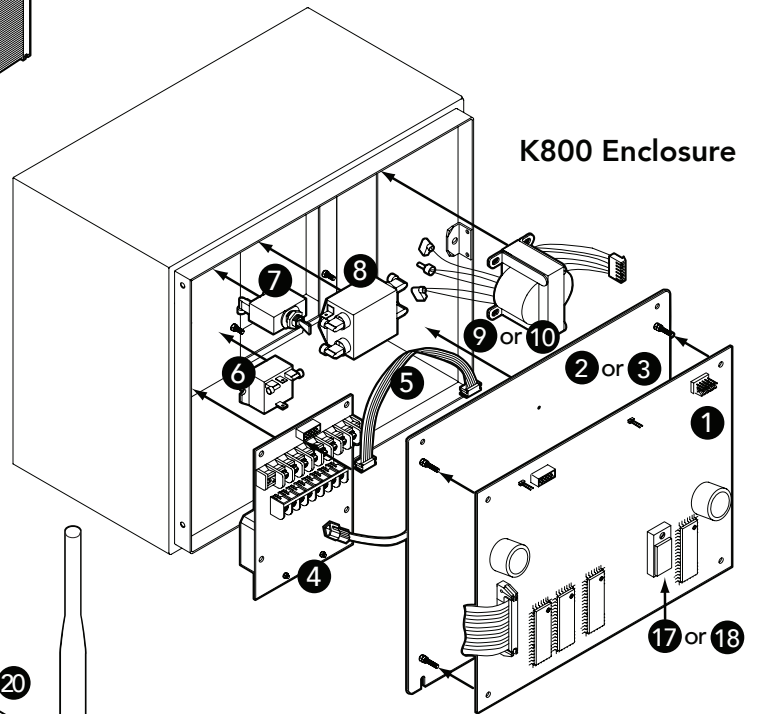

K800 Enclosure

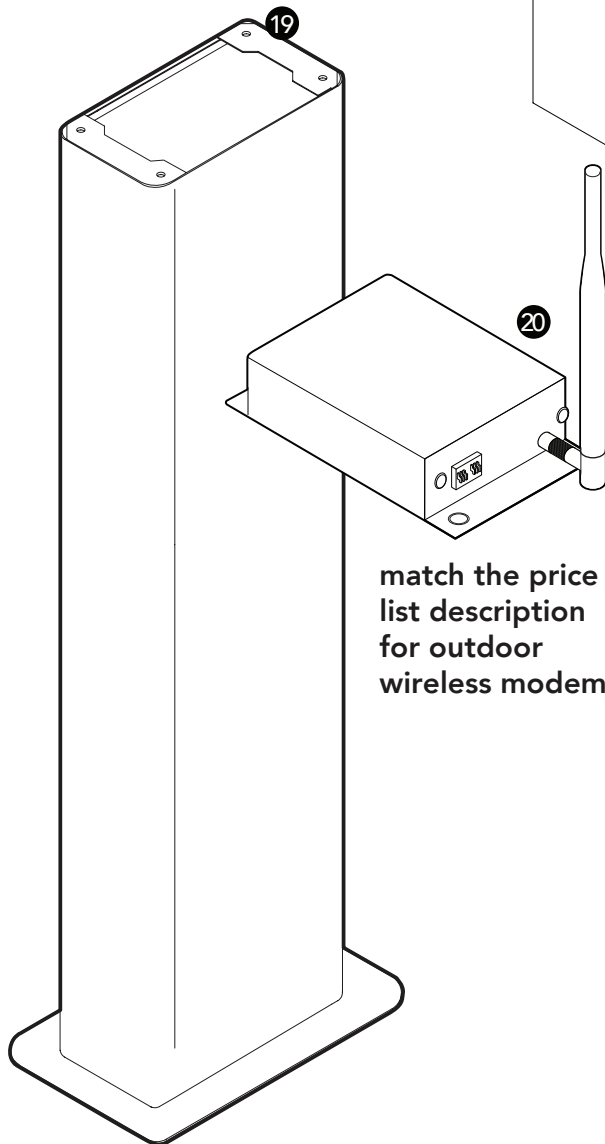

match the price  
list description  
for outdoor  
wireless modem

## K800 FIT Parts

1. PV247 Fuel Island Terminal Board.....	R20-0222
2. 115V Heater Assembly .....	20-4138
3. 230V Heater Assembly .....	20-4138-230
4. PV240 Pump Relay Board .....	R20-0218
5. PV247 to PV240 Cable.....	20-1442
6. Heater Relay.....	06-0015
7. Fuel Island Terminal Power Switch.....	09-0007
8. Corcom Filter .....	02-4001
9. 110V Fuel Island Terminal Transformer Assembly .....	20-5023
10. 230V Fuel Island Terminal Transformer Assembly .....	20-5023-230
11. PV241 K800 Display Assembly.....	20-0219
12. Fuel Island Terminal Main Cable .....	20-1441
13. Keypad Assembly.....	20-4136
14. Emergency Stop Button .....	20-5017
15. ChipKey® Reader Assembly.....	20-4117
16. Magnetic Cardreader.....	75-3006
17. K800 FIT Software .....	S08501
18. K800 FIT Software Spanish.....	S08504
19. K800 Pedestal .....	20-4137
20. Modem for Additional FITs .....	20-7075