

Warranty

All parts and products are thoroughly inspected and tested from the time raw material is received at our plant, until the product is completed. We guarantee that all products are free from defects in materials and workmanship for a period of one year from the date of shipment. Any product that may prove defective within said one year period will, at our discretion, be promptly repaired, replaced or credit given for future orders. This warranty shall not apply to any products which has been altered in any way, which has been repaired by any party other than an authorized service representative, or when such a failure is due to misuse or condition of use. We shall have no liability for labor costs, freight costs or any other costs or charges in excess of the amount of invoice for the products.

THIS WARRANTY IS IN LIEU OF ALL OTHER WARRANTIES, EXPRESS OR IMPLIED AND SPECIFICALLY THE WARRANTIES OF MERCHANTABILITY AND FITNESS FOR A PARTICULAR PURPOSE.

WARNING!!

CIVACON products should be used in compliance with the applicable federal, state and local laws and regulations. Product selection should be based on physical specifications and limitations, compatibility with the environment, and the material being handled.

CIVACON MAKES NO WARRANTIES OF FITNESS FOR A PARTICULAR PURPOSE.

TECHNICAL ASSISTANCE

If at any time during the installation a question arises that is not covered in this manual or with any other applicable documents feel free to call the Customer Service Department or visit our website at **www.civacon.com**.

In the U.S., call 1-888-526-5657
In all other countries, call your local agent.



PHONE: (816) 741-6600 • (888) 526-5657 • Fax: (816) 741-1061
4304 Mattox Road • Kansas City, MO 64150 • www.civacon.com



12149PA

Rev. C, JAN. 2011

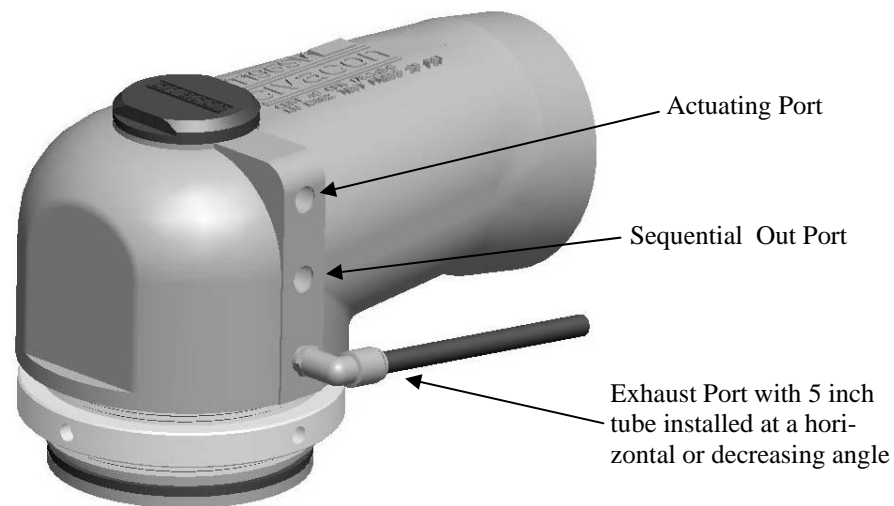

Product Description

Civacon's T196SV sequential vapor recovery vent design increases flow while loading and unloading. This vent is designed to work on a 16" Manhole cover. The T196SV conforms to API 1004 and EN13083 regulations. Civacon's T196SV is a direct replacement for the 1986SV and all competitors' vapor recovery vents. Compatible with diesel, biodiesel, gasoline, ethanol and methanol

Manual

This manual contains the inspection, maintenance schedule and instructions for repairing and replacing parts for the T196SV vapor recovery vent. The following schedule, based on the environmental conditions in the northern United States, is only a recommendation: *Inspection and maintenance intervals must be adjusted according to use and operating conditions.*



PHONE: (816) 741-6600 • (888) 526-5657 • Fax: (816) 741-1061
4304 Mattox Road • Kansas City, MO 64150 • www.civacon.com

Semi-Annual Inspection

Visually inspect and test the vent for proper operation. This inspection can be done without removing the vent from the trailer. *Follow all safety procedures.*

Visual Inspection

1. Poppet gasket surface and poppet gasket condition to be visually inspected with poppet in extended position. See **Figure 1**
2. If gasket shows sign of damage, gasket should be replaced and vent rebuilt. See Vapor Vent Rebuild Procedure.
3. Contact Civacon at (888) 526-5657 for seal replacement kit (PN: T196SVRK)

None sequential applications:

Install the provided 1/8 NPT plug in the sequential port

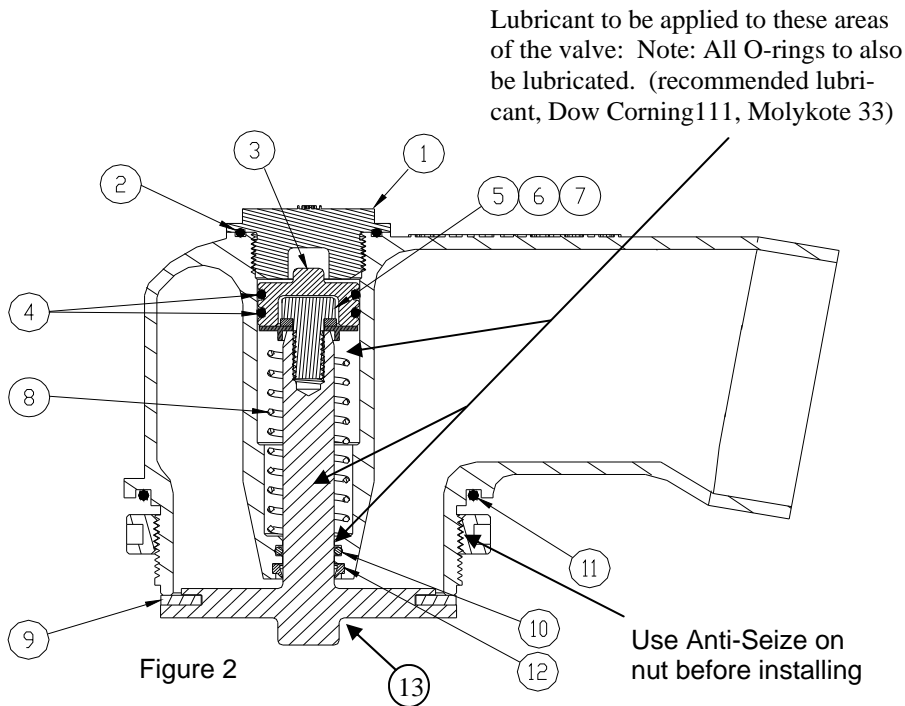

T196SV Vapor Vent Rebuild Procedure

1. Review **Figure 2** before starting rebuild.
2. Remove cap 11672 (1) and O-ring 11692 (2).
3. Remove piston 11772 (3) and O-ring 11776 (4).
4. Using 9/16" socket remove bolt H20518M (5), lock washer 9990 (6) and spring guide 11990 (7). Be careful upon removal, spring is under pressure from bolt.
5. Remove spring 11694 (8).
6. Remove poppet (13) from housing and replace gasket 12007 (9).
7. Remove O-ring 10681M (10) and wiper 11696 (12).
8. Clean out bore and O-ring grooves if needed
9. Install new O-ring 10681M (10) and Wiper 11696 (12)
10. Apply lubricant throughout bore and O-rings
11. Insert spring 11694 (8).
12. Fasten bolt H20518M (5), new lock washer 9990 (6) and new spring guide 11990 (7). To poppet shaft. Using a 9/16 socket on the bolt side and wrench holding the flats on the bottom side of the poppet. Tighten bolt to 22ft-lb.
13. Insert new piston 11772 (3) with Lubricate O-rings 11776 (4)
14. Install O-ring 11692 (2) and cap 11672 (1).
15. Replace O-ring H20124M (11).
16. Replace exhaust port air tube with new air tubing approx. 5" long
17. Test vent operation by cycling the vent open and closed by applying air to inlet port.

Exhaust Port Caution: Exhaust port must not be allowed to be submerged in water and port must remain free of obstructions. The fitting shall be installed in a horizontal or a decreasing angle as provide from the Civacon factory. The exhaust tube opening should not be allowed to rest on the manhole cover. The tube should be overhanging the manhole assembly.

Alternate exhaust configurations: If you believe that the exhaust tube may be submerged in water at times due to inadequate drainage we recommend daisy chaining all exhaust ports together and locate the exiting tube where it will not be restricted (i.e. midway down the back of the tank).