

INSTALLATION INSTRUCTIONS

Fibrelite Multiport & Offset Fill Sump Systems



These instructions are for installing Fibrelite S8, S14 and S15 series fill sumps with FL90 or FL100 multiports or offset fill covers.

S8CR Multiport System shown

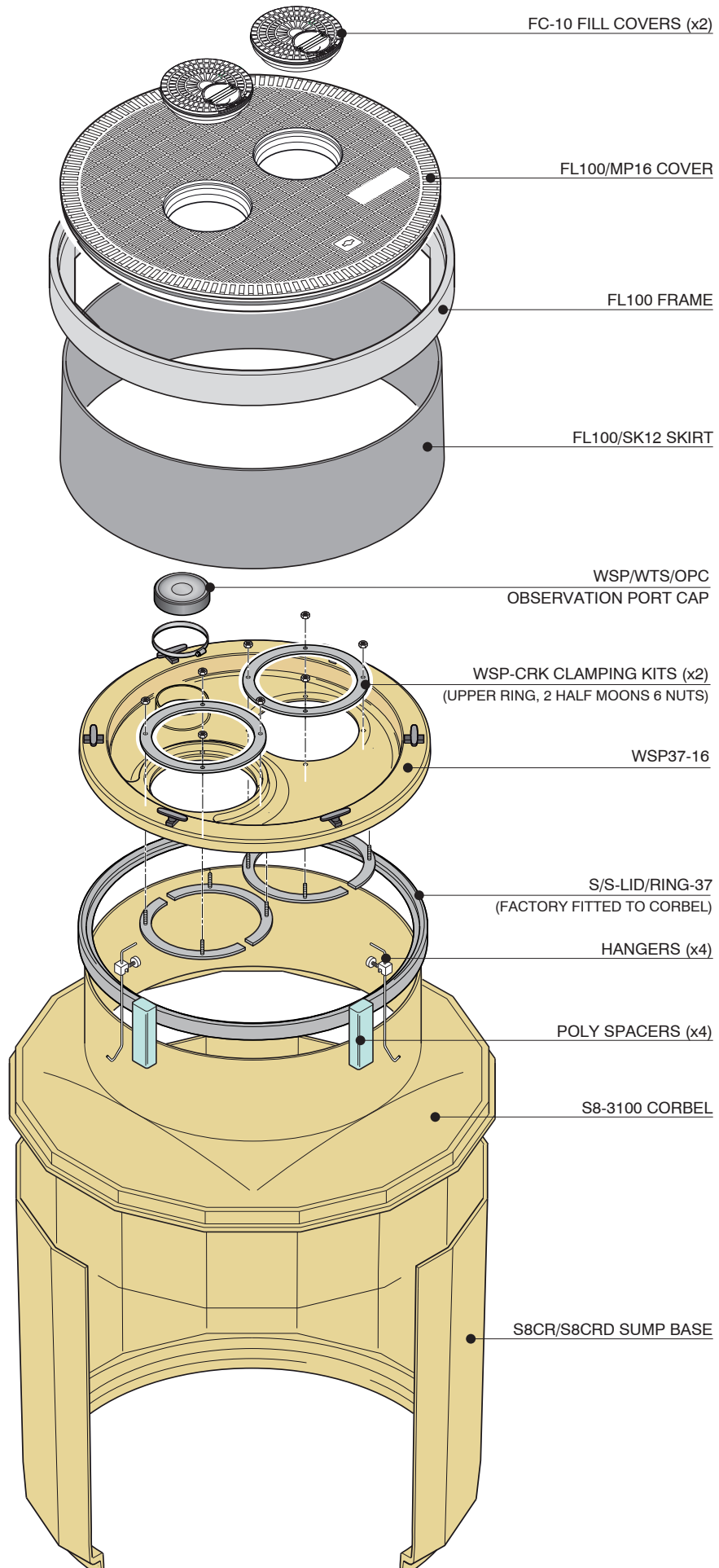
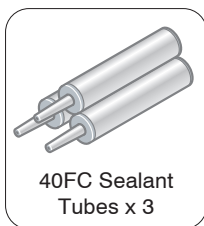
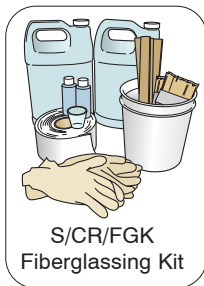
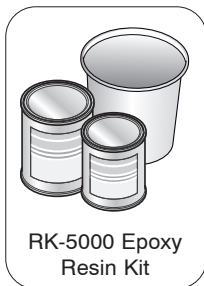

Fibrelite Multiport & Offset Fill Sump Systems (Inspecting Parts and Achieving Correct Sump Height)



DO NOT STORE SUMPS ON THEIR SIDES PRIOR TO INSTALLATION

STOP Failure to follow this instruction may cause the sumps to deform and become “out of round.” When installed onto the tank collar, the out-of-round sump base may be difficult to connect to the round tank sump corbel. Store sumps on either round end to prevent this from happening.

1 Using the packing list and the drawing on the front page of these instructions as a reference, **confirm that all sumps, manholes and related parts and accessories have been received.**

2 Install string lines at finished grade level (manhole grade level) across the length and width of the tank farm (as shown below) in order to accurately measure the distance from grade level to the tank top.

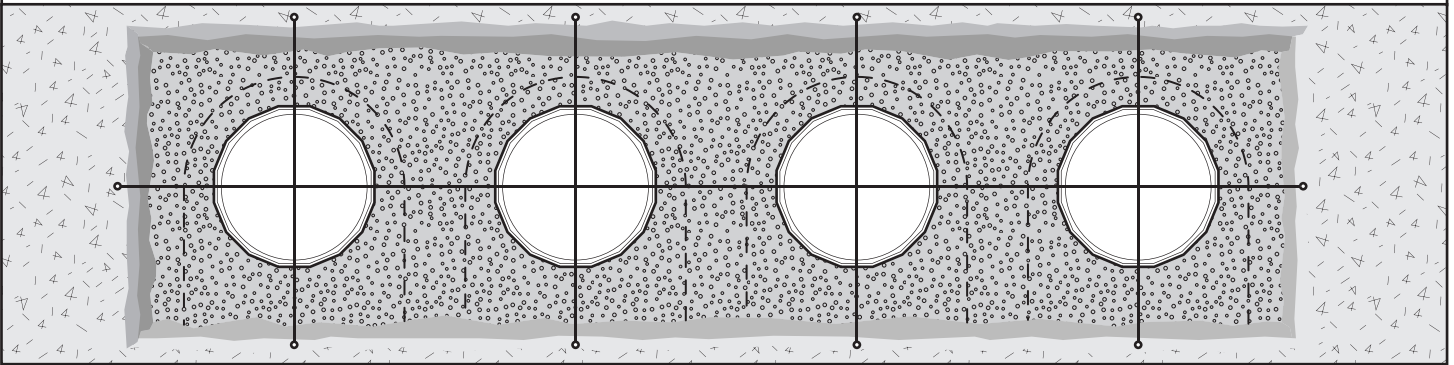

3 Place the sump bases onto each of the tank collars (“dry fit” the sump base at this stage). Mark the sump to reflect the tank it is installed on. Measure the distance from the string line to the top of the sump and note the measurement in a log or on the side of the sump.

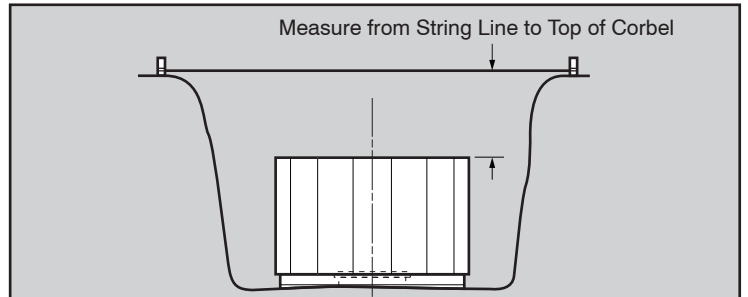
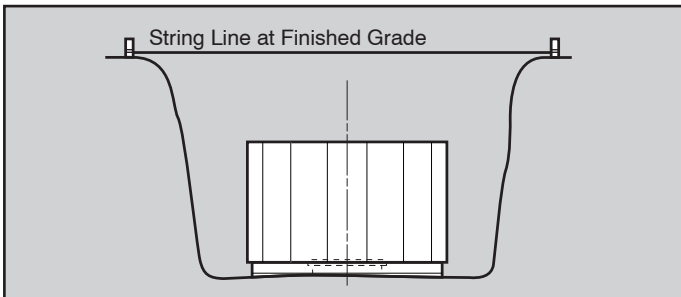

4 As shown in the drawing to the right, the top of the 42” diameter sump base must be 20” below the string line set at finished manhole grade level. This will provide sufficient clearance for both the Fibrelite corbel and the watertight spill platform.

If the sump base is more than 20” below the string line, it will be necessary to install a 12” extension and trim it so the combined sump base and extension are 20” below the string line. If the sump base is less than 9” from the string line, it will be necessary to use a shorter sump base. The S8 series sumps have deep, normal and shallow sump bases to handle such issues.

Note: For more detail, please refer to the drawing shown on page 13 showing finished fill sump installation showing all critical dimensions.

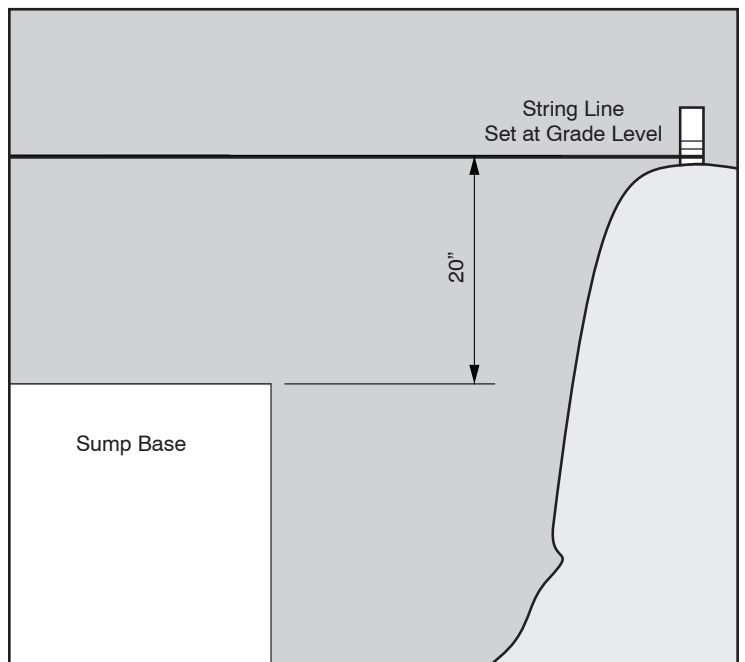

Fibrelite Multiport & Offset Fill Sump Systems (Trimming Sump Base to Achieve Correct Sump Height)



5

If the sump base must be trimmed, mark the trim line on the sump base using an indelible marker - make sure to mark a level line on the tank sump for cutting (use a locked tape measure as shown). If the line is not level, re-measure and re-mark until the marked line is correct and level. The sump and corbel will not seal properly if the cut is jagged or uneven.

STOP The S8 sump may be trimmed a maximum of 13" from the top. If this is not sufficient, contact your distributor or Fibrelite to arrange for a shorter sump base. If the sump is trimmed more than 13", it may be difficult to fit the tophat onto the sump base.

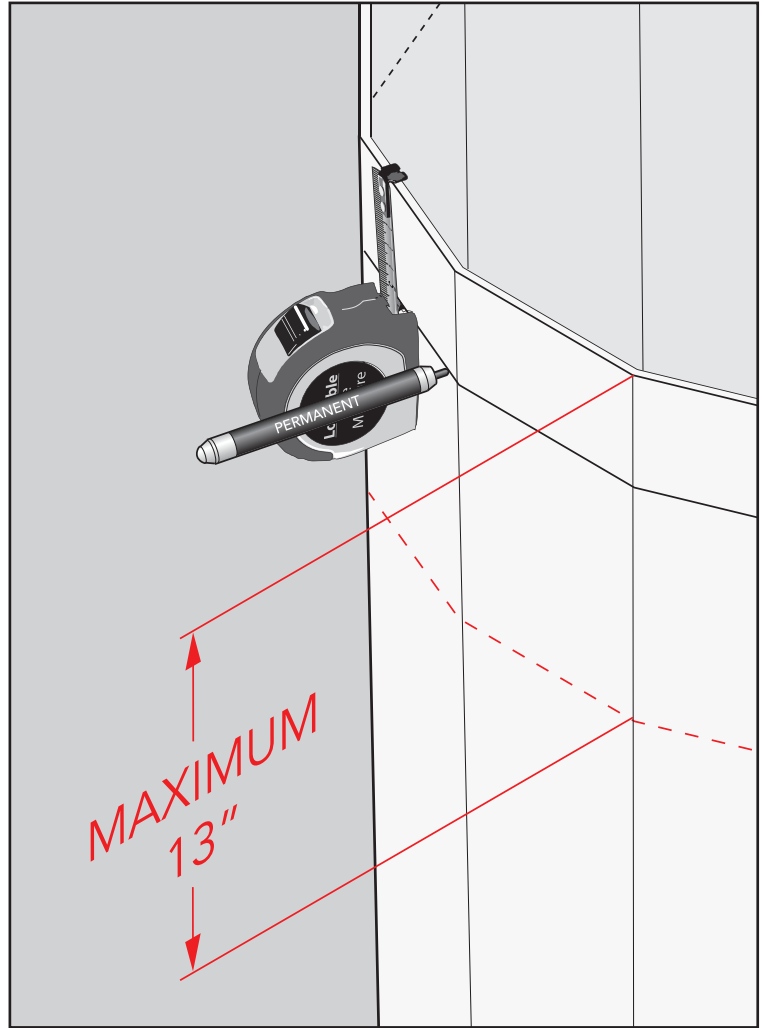

6

Use an appropriate cutting tool and blade such as a diamond blade cutter (as shown in the drawing) to ensure that the sump is cut evenly.

A jagged or uneven cut made with a reciprocating saw will be difficult to seal when the corbel is installed.

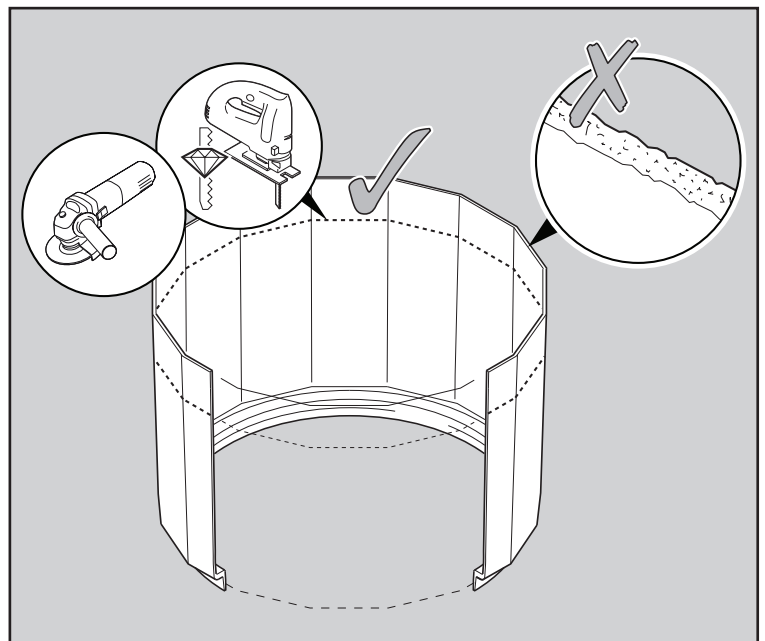

Fibrelite Multiport & Offset Fill Sump Systems (Preparing tank collar and sump base for fibreglassing)



NB: - Correct preparation is essential!

Failure to correctly prepare the surface prior to fibreglassing may result in a “WEAK” joint and subsequent failure.

7

The surface of the tank collar must be prepared properly prior to fibreglassing – use an angle grinder to expose the fiberglass surface to ensure good fibreglassing. If grinding is not possible, sand by hand - use heavy grit sandpaper to ensure that the fiberglass surface is properly exposed.



Do not grind the tank collar with an electric grinder unless all appropriate safety procedures for open tank pits have been followed. If there is any risk that gasoline vapors may be present in the tank pit, use only explosion-proof or air-powered tools or sand the collar by hand.

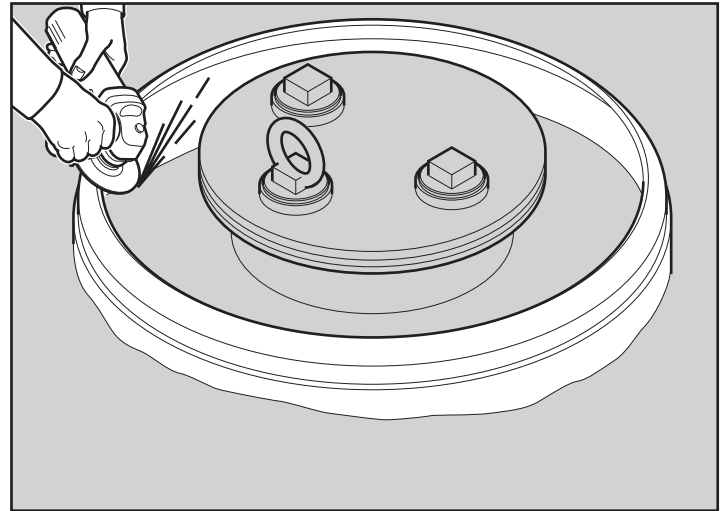

8

The surface of the tank sump collar must also be properly prepared prior to fibreglassing.

Sand both the internal and external sides of the collar.

If grinding is not possible, sand by hand - use heavy grit sandpaper to ensure that the fiberglass surface is properly exposed

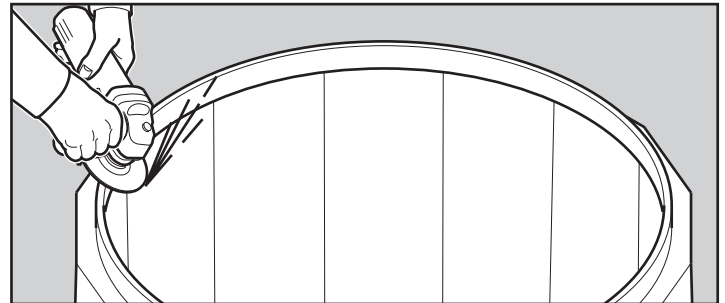

9

All abraided surfaces must be wiped clean with acetone (or equivalent replacement) immediately prior to fibreglassing to ensure that no dust or dirt is present on the surfaces.

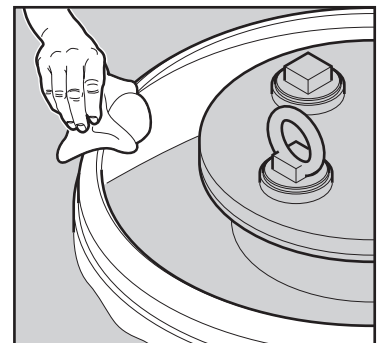
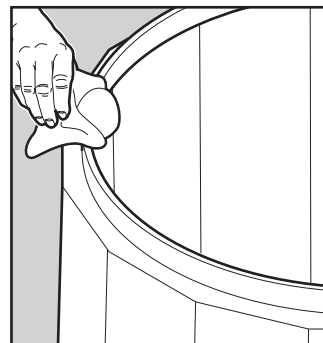

10

Immediately after cleaning, install the tank sump onto the tank collar.

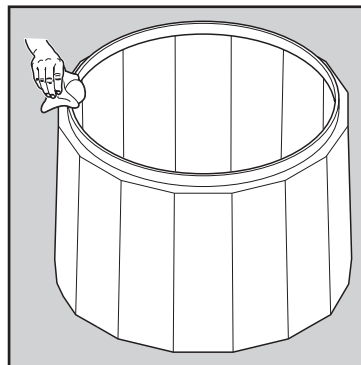

11

Note: Prior to fibreglassing the sump to the tank collar, dry fit it onto the collar and position so that the sump facets align perpendicular with the pipework exit/entry points.

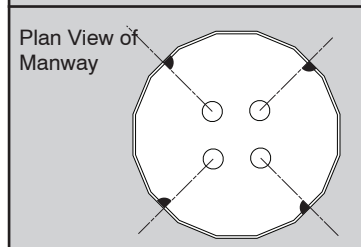

12

Use a level to properly set the tank sump in place – make sure the sump will be level to finished grade.

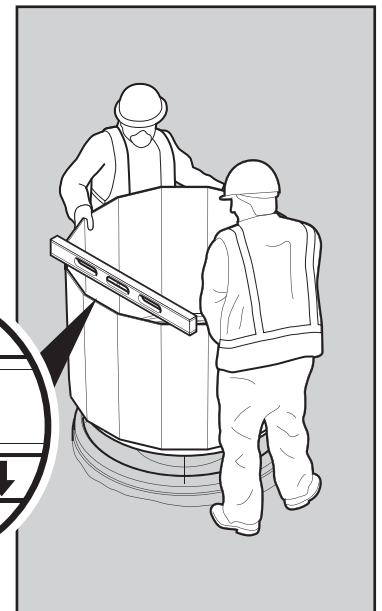
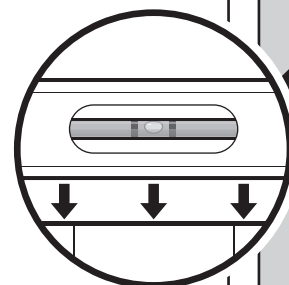

Fibrelite Multiport & Offset Fill Sump Systems (Fiberglassing the sump base to the tank collar)



S/CR/FGK Fiberglassing Kit

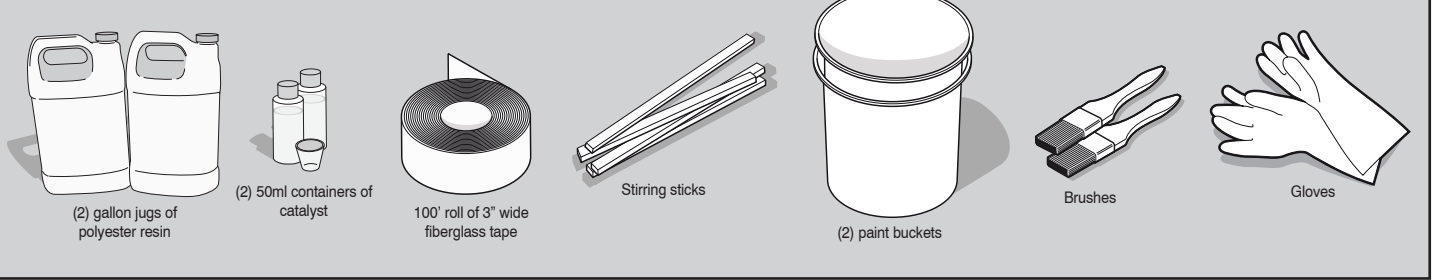

13 At 60°F, mix 1 quart resin with 15ml catalyst and stir well. Note: Detailed tank collar fiberglass instructions are packed in fiberglassing kit.

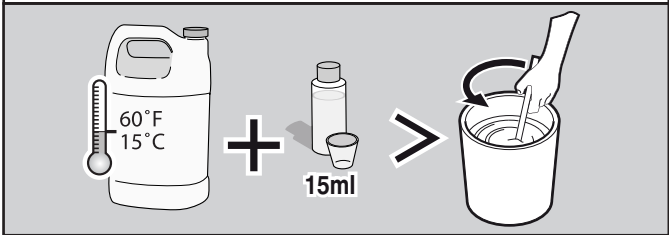

14 Using brush, paint resin onto sanded surfaces at the tank collar joint. Apply resin around circumference of the tank collar.

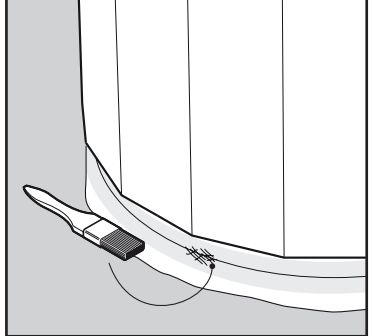

15 Apply a layer of fiberglass tape by centering it on the tank collar joint and unrolling it completely around the sump keeping it centered over the joint (this will require 2 people). Cut the tape once the first layer is applied."

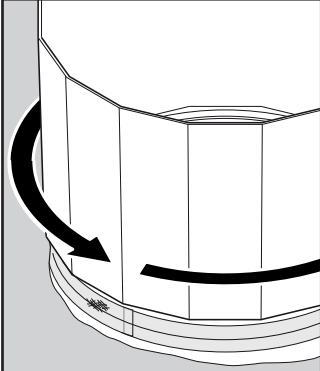

16 Apply a second and third layer of fiberglass tape by repeating steps 14 and 15 ensuring that all joints are staggered and overlap by a minimum of 2. Paint a final layer of resin onto the third layer of fiberglass and use the brush to flatten out any bubbles or air pockets.

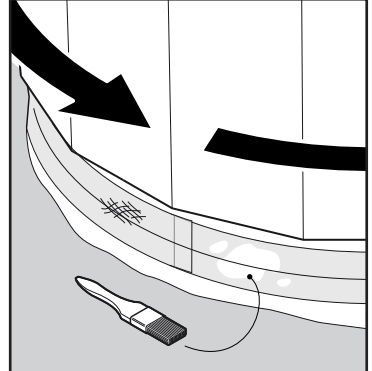

17 Allow approximately one hour for the resin to cure before proceeding with any other work on the tank sump. Allow 24 hours before putting any stress on the sump.

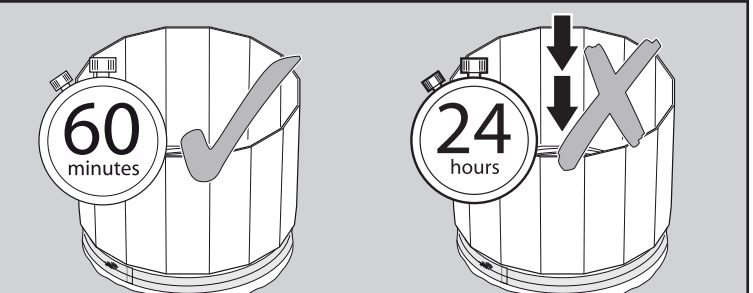

18 Apply fiberglass tape only at the tank collar to tank sump joint. Fiberglassing on the sump body may cause distortion after the resin has dried.

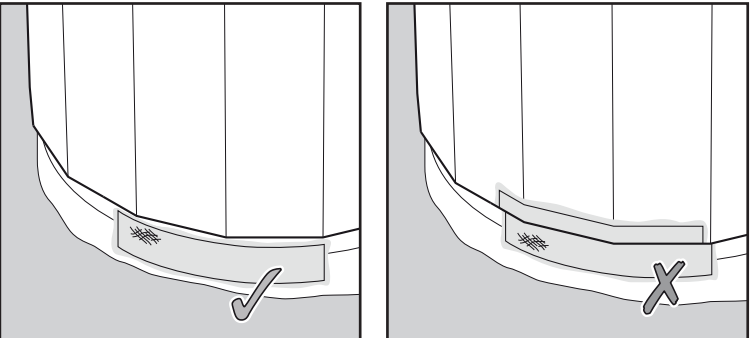

SPECIAL NOTES: Fiberglassing the Tank Collar Joint: Fibrelite recommends fiberglassing the outside of the tank collar joint with 3 layers of glass as an added precaution against water intrusion (especially in high water areas).

Fibrelite Multiport & Offset Fill Sump Systems (Pouring the inner tank collar joint)



RK-5000 Epoxy Resin Kit

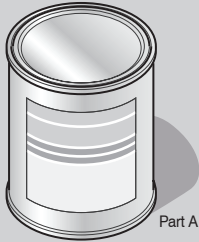

Part A



Part B

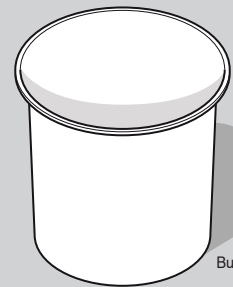

Bucket

19

In **addition** to fiberglassing the outside tank collar joint, the inner tank collar joint should be filled with an epoxy resin to ensure that the joint will be watertight. Use part # RK-5000 Epoxy Resin Kit and follow detailed instructions packed with kit.

20

Prepare the inner tank collar joint and tank sump mating surfaces by sanding or grinding – surfaces previously sanded should be cleaned with acetone.

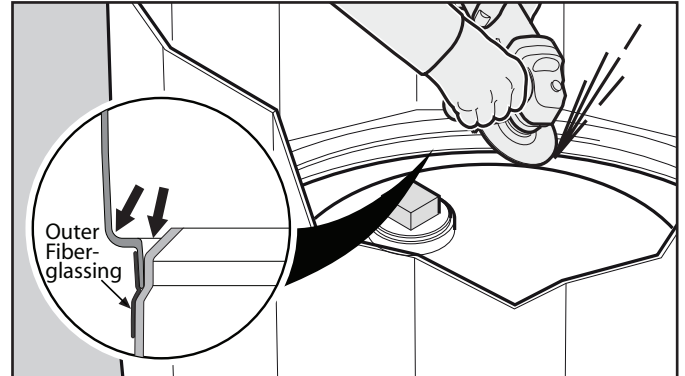

21

Prepare epoxy resin by thoroughly mixing Part A and Part B in the mixing bucket. Keep material above 60°F until immediately prior to use.

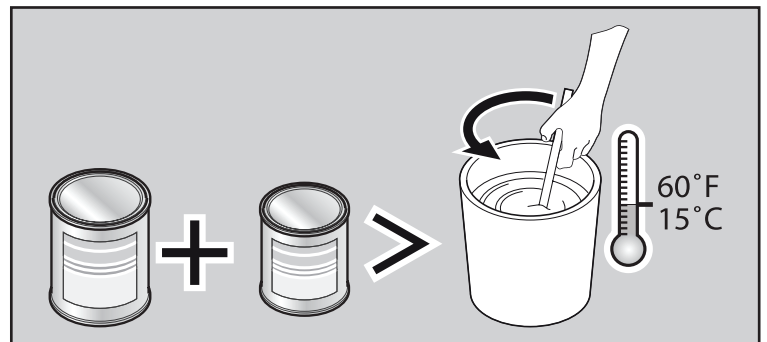

22

Apply epoxy resin filler by pouring the epoxy into the joint between the tank collar and the tank sump.”

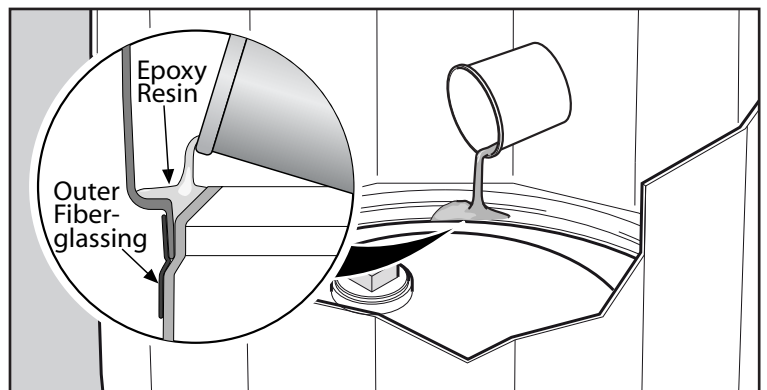

23

Allow approximately 4 hours for the resin to cure before proceeding with any other work on the tank sump. Allow 24 hours before putting any stress on the sump.

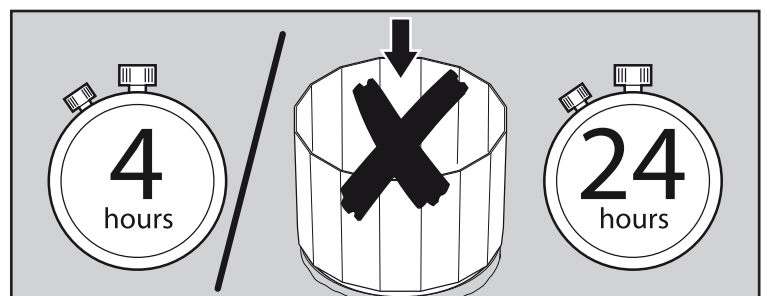

Fibrelite Multiport & Offset Fill Sump Systems (Installing Penetration Fittings)

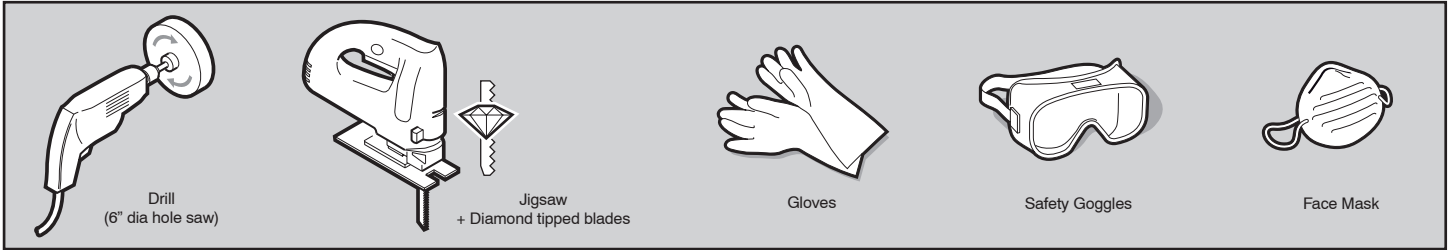

24 **WARNING** Care must be taken to position the pipework and conduit so it exits the sump at 90° angle to the sump wall. Otherwise undue stress will be placed on the sump wall and entry boot, which may lead to leaks in the future.

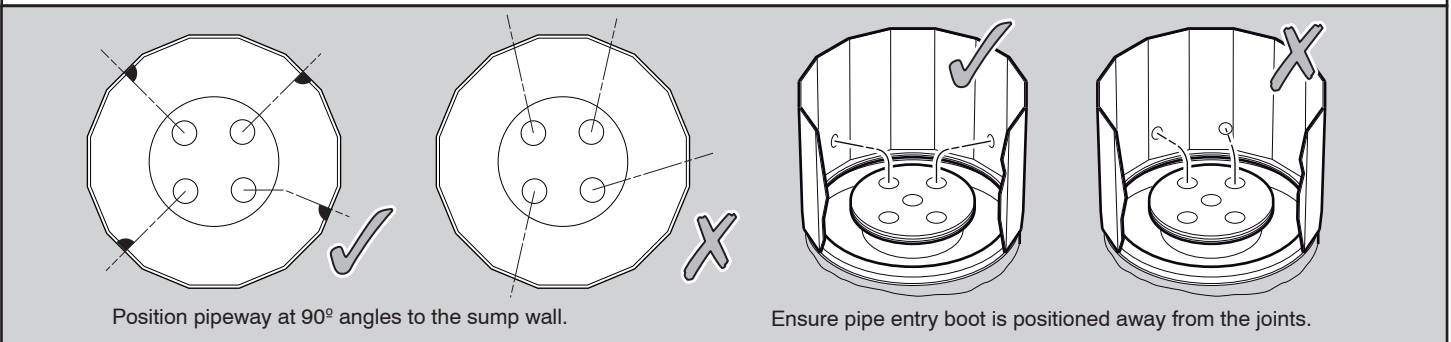

25 Prior to installing pipework, install a string line at grade level and determine if the sump base will first need to be trimmed.

All height adjustments must be made to the sump base and not to the corbel. To allow sufficient clearance for the corbel and watertight lid under the manhole cover, the top of the sump base must be at least 18" and ideally 20" below grade. Refer to the measurement chart located on page 2 for more detailed instructions.

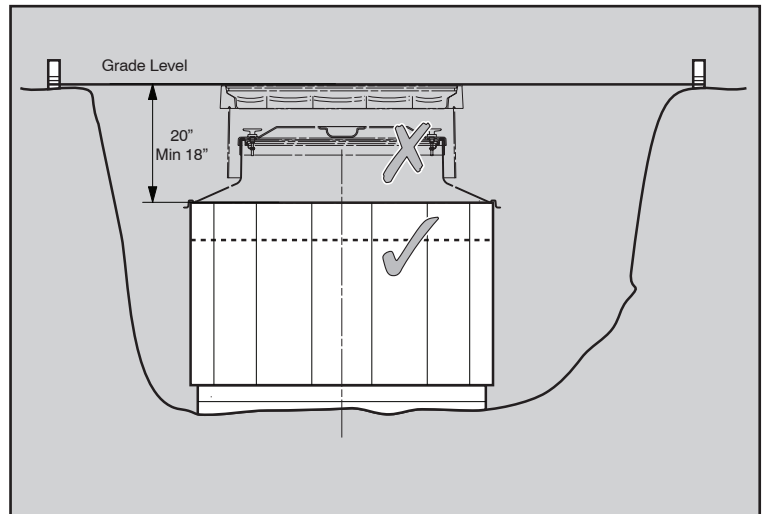

26 Mark a center point in the center of a sump panel. Drill a pilot hole to ensure the hole saw can be positioned and used safely.

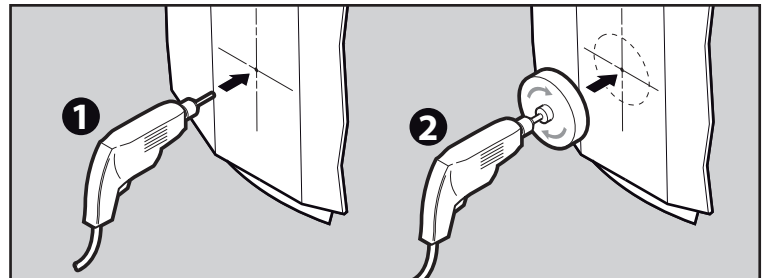

27 For holes larger than 6" diameter, we recommend using a jigsaw to cut the hole. Drill a pilot hole prior to inserting the jigsaw blade. As fiberglass will blunt normal blades very quickly, always use a diamond tipped blade.

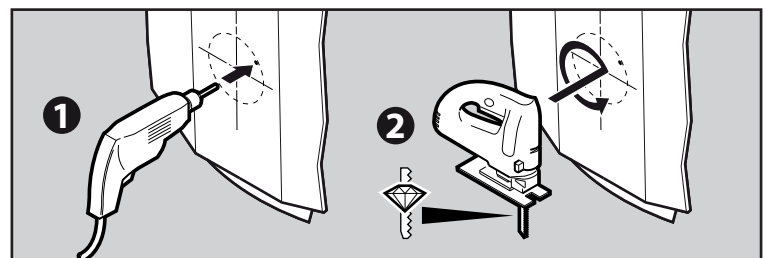

NOTE : When backfilling ensure the pipework is not disturbed.
WARNING : Do not backfill until the sump has been vacuum tested.

Fibrelite Multiport & Offset Fill Sump Systems

(Bonding the Extension to the Sump Base - Required Only for Deep Burial)

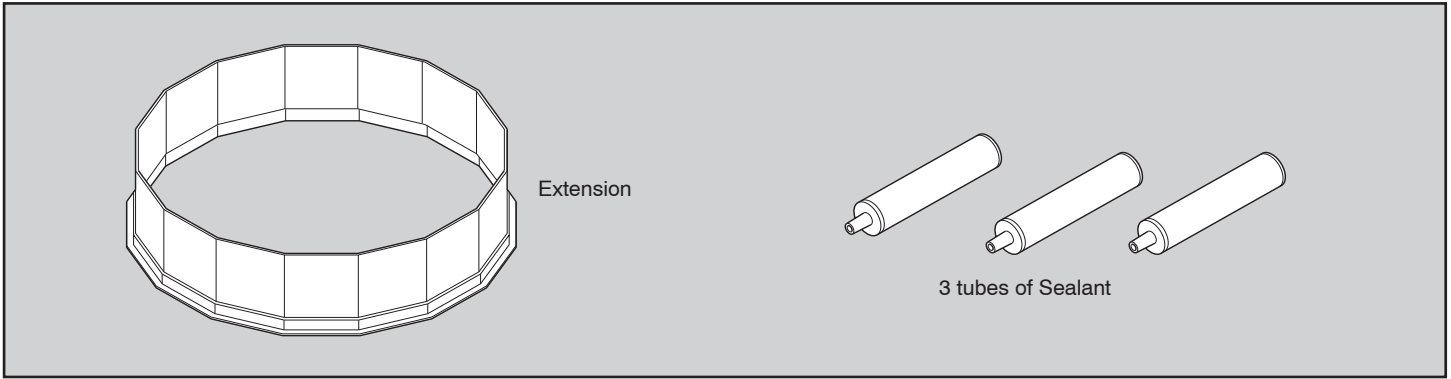

28 **NOTE:** If the burial depth of the tank requires the use of a sump extension, contact your distributor and order the appropriate extension.

Prepare the mating surfaces of the tank sump base and the downward facing groove on the extension (as shown at right). Use heavy grit sandpaper to ensure that the fiberglass surface is exposed. After sanding, clean both surfaces using acetone (or equivalent solvent).

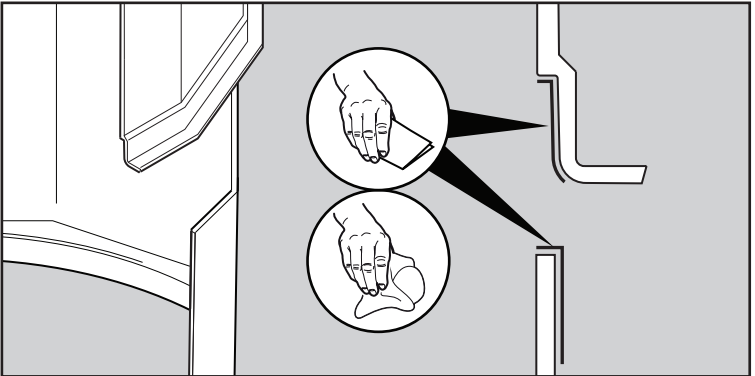

29

Cut nozzle of the adhesive sealant tube to approximately $\text{Ø } 5/16''$.

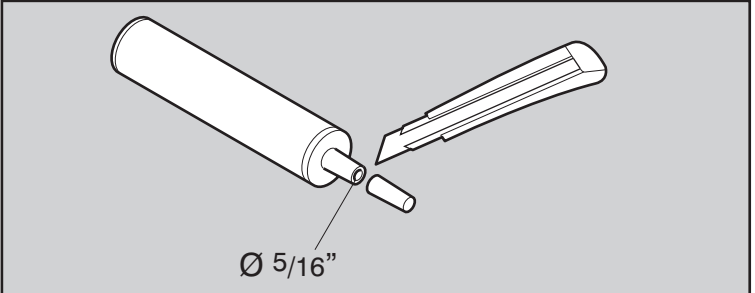

30

To permanently fix the extension, invert the extension and apply a bead of adhesive sealant to the vertical wall of the extension recess.

Position the extensions(s) onto the chamber, ensure the extension is horizontal and press down uniformly.

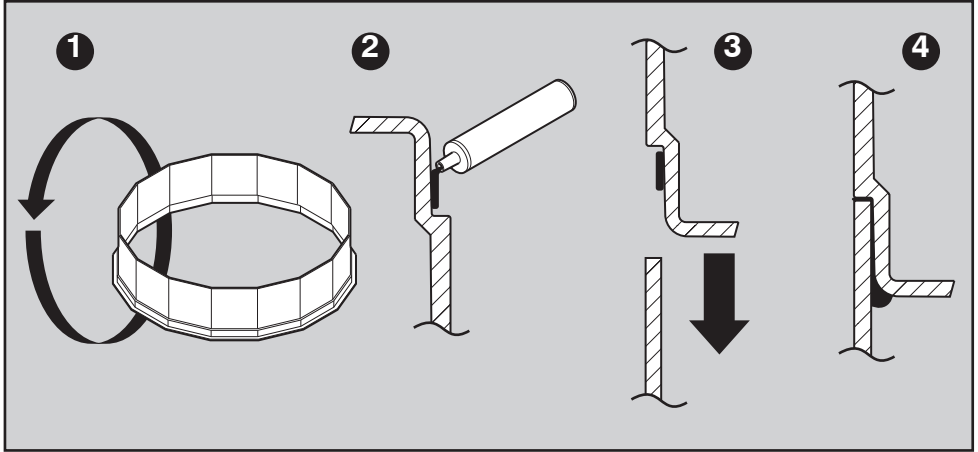

31

Remove excessive adhesive sealant from the internal joint with a scraper and smooth off.

Apply a bead of adhesive sealant (same nozzle size) to the external horizontal joint and smooth off.

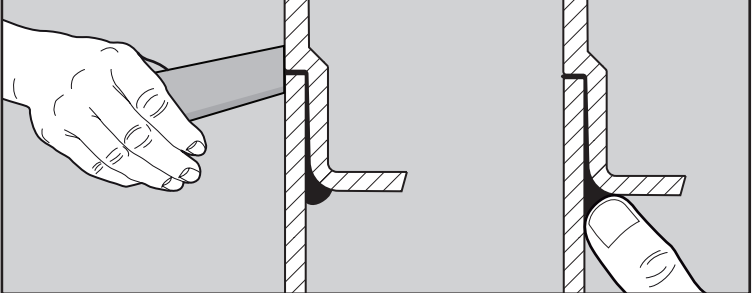

Fibrelite Multiport & Offset Fill Sump Systems (Bonding the corbel to the sump base or extension)

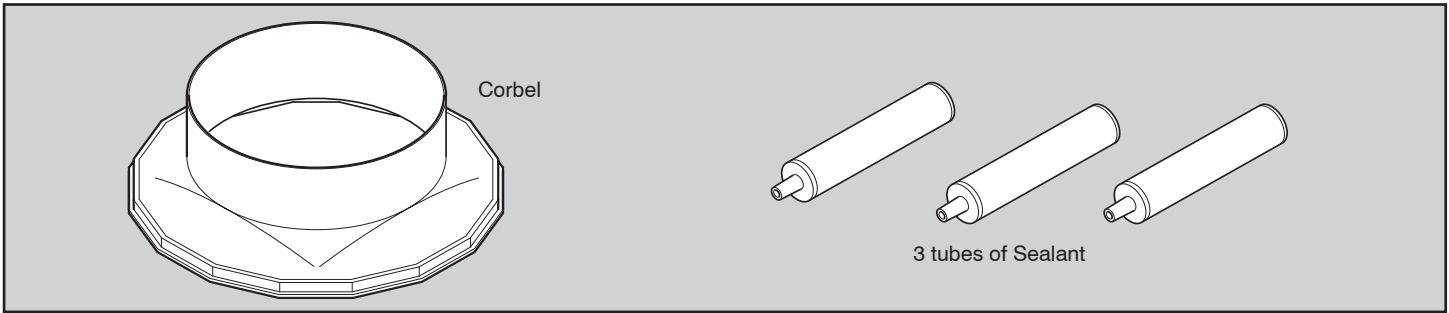

32 Prepare the mating surfaces of the tank sump base (or extension) and the downward facing groove on the corbel (as shown at right).

Use heavy grit sandpaper to ensure that the fiberglass surface is exposed. After sanding, clean both surfaces using acetone (or equivalent solvent).

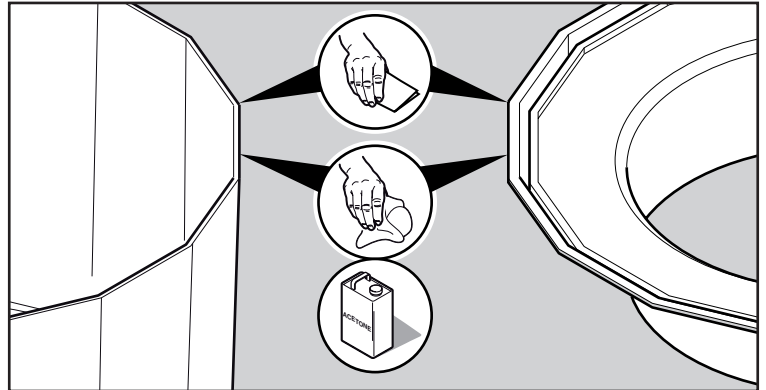

33 Dry fit the corbel on the sump to ensure it fits - push corbel groove onto sump wall,

If the corbel does not fit properly onto the sump wall, measure the inside diameter of the sump walls (as shown to the right). The measurement should be between 45 1/2" and 46" (+/- 1/4"). If the measurement is not within these specifications, the sump may have become out-of-round due to improper storage or installation.

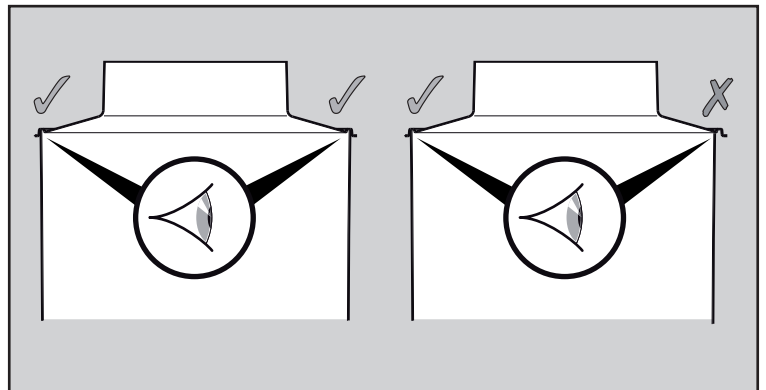

34 To fix an out-of-round sump base, first find the shortest distance between any 2 sump walls. Using a wooden 2x4 cut to 45 1/2" length, install the 2x4 at an angle into the sump and use it to brace out the sump walls to the correct size. Repeat this process on all sump walls to return the sump to its correct size.

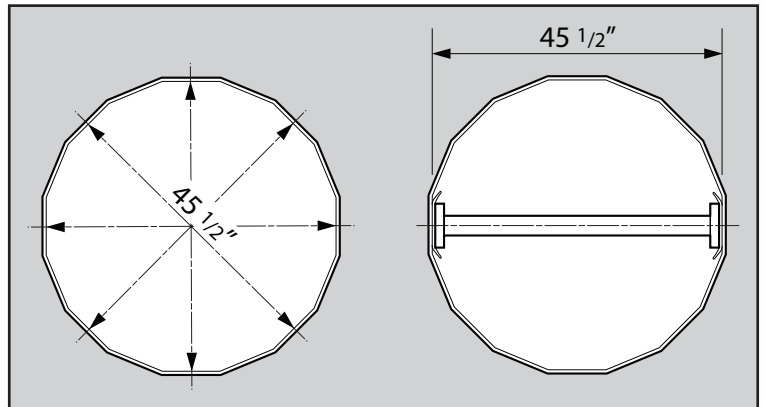

35 Apply 2 tubes of sealant in the groove of the corbel. Sealant should fill half the groove.

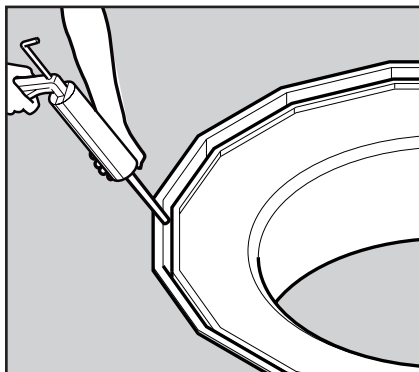

36 Place the corbel on the sump using 2 people and push it into position.

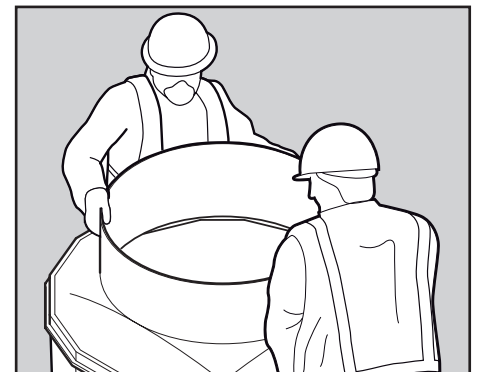

Fibrelite Multiport & Offset Fill Sump Systems (Bonding the Corbel)



37 Seal around the inside edge of the corbel joint from inside the sump. Smooth off the sealant with soapy water.

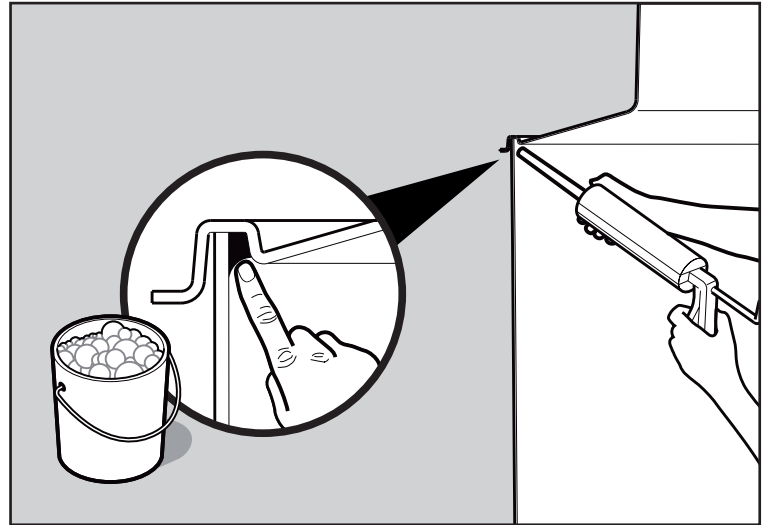

38 Seal around the outside joint and smooth off sealant with soapy water.

Note: If also fibreglassing the outside corbel joint as set forth on the next page, clean off any residual sealant on the flat surface of either the corbel lip or the top of the sump base.

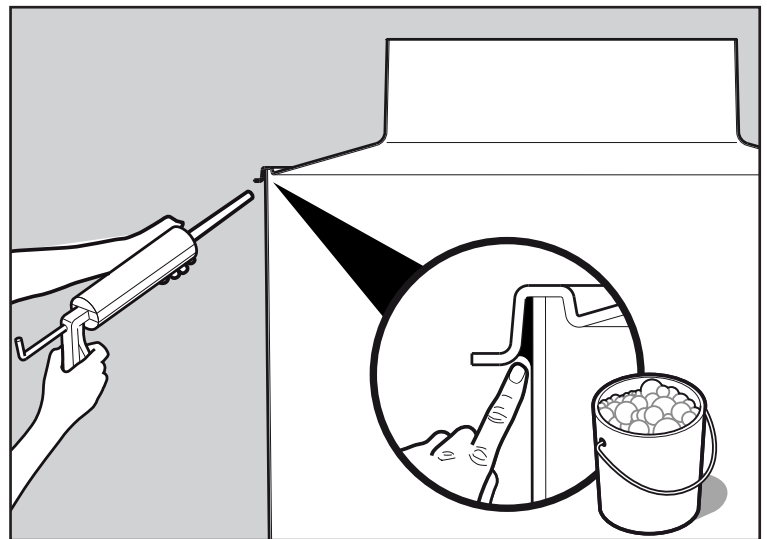

Fibrelite Multiport & Offset Fill Sump Systems (Fiberglassing the corbel to the sump base)



S/CR/FGK Fiberglassing Kit

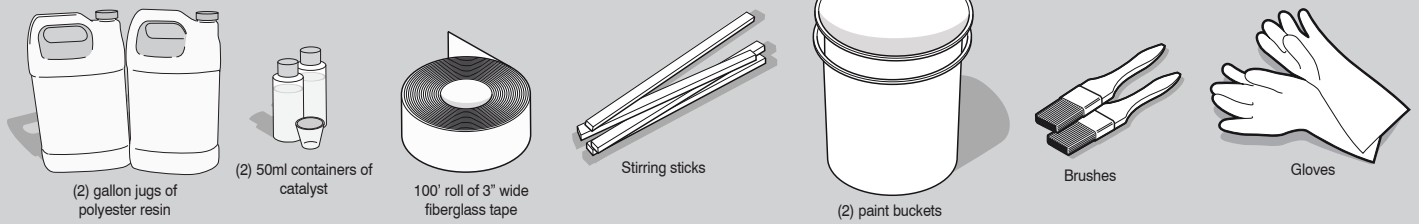

39 At 60°F, mix 1 quart resin with 15ml catalyst and stir well.

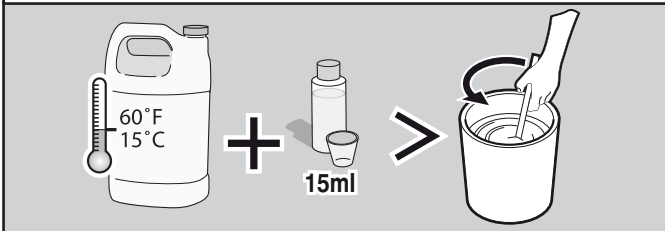

40 Prepare the mating surfaces of the tank sump base (or extension) and the downward facing groove on the corbel (as shown at right).

Use heavy grit sandpaper to ensure that the fiberglass surface is exposed. After sanding, clean both surfaces using acetone (or equivalent solvent).

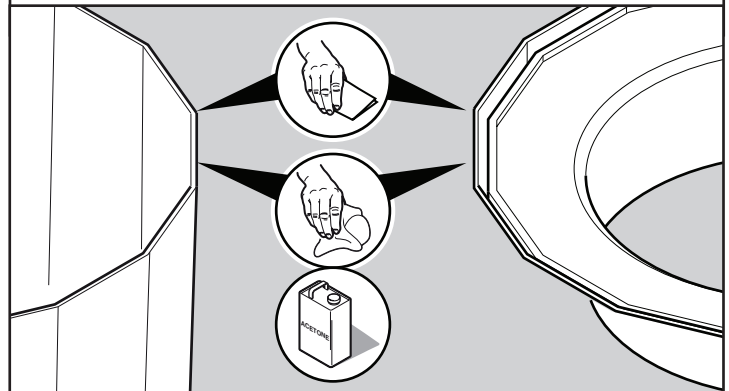

41 Using brush paint resin onto sanded surfaces at the corbel to sump base joint. Apply resin around the surface of the corbel.

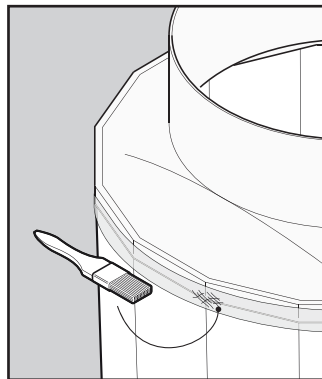

42 Apply a layer of fiberglass tape by centering it on the corbel to sump base joint and unrolling it completely around the sump keeping it centered over the joint (this will require 2 people). Cut the tape once the first layer is applied."

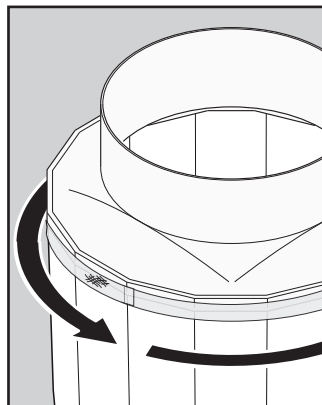

43 Apply a second and third layer of fiberglass tape by repeating the previous 2 steps ensuring that all joints are staggered and overlap by a minimum of 2. Paint a final layer of resin onto the third layer of fiberglass and use the brush to flatten out any bubbles or air pockets.

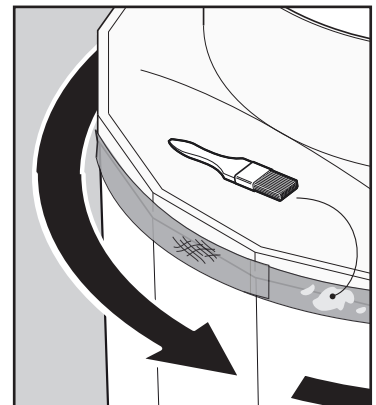

44 Allow approximately one hour for the resin to cure before proceeding with any other work on the tank sump. Allow 24 hours before putting any stress on the sump.

Important: As a final step, always seal the inside joint of the corbel using Fibrelite sealant. Follow the steps shown in the "Bonding the corbel to the sump base" instructions.

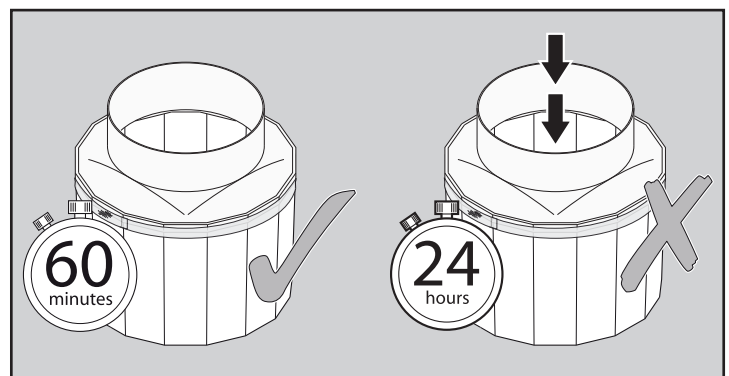

Fibrelite Multiport & Offset Fill Sump Systems (Performing Hydrostatic or Vacuum Testing)



45 Wait a min of 12 hours before vac testing, preferably overnight to allow sealant to set before vacuum or hydrostatic testing.

Do not disturb the sump during this time.

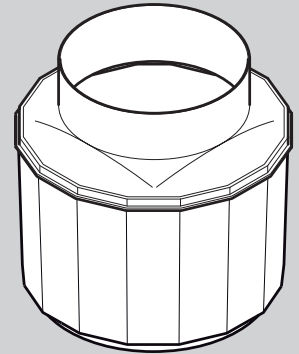

46 Ensure all pipework and electrical entries have been completed before vacuum or hydrostatic testing, this is a final test for all penetrations in the sump.

Warning: If vacuum testing, test the corbel at a 24" depth setting only or irreparable damage may occur.

Refer to vacuum testing instructions for correct method.

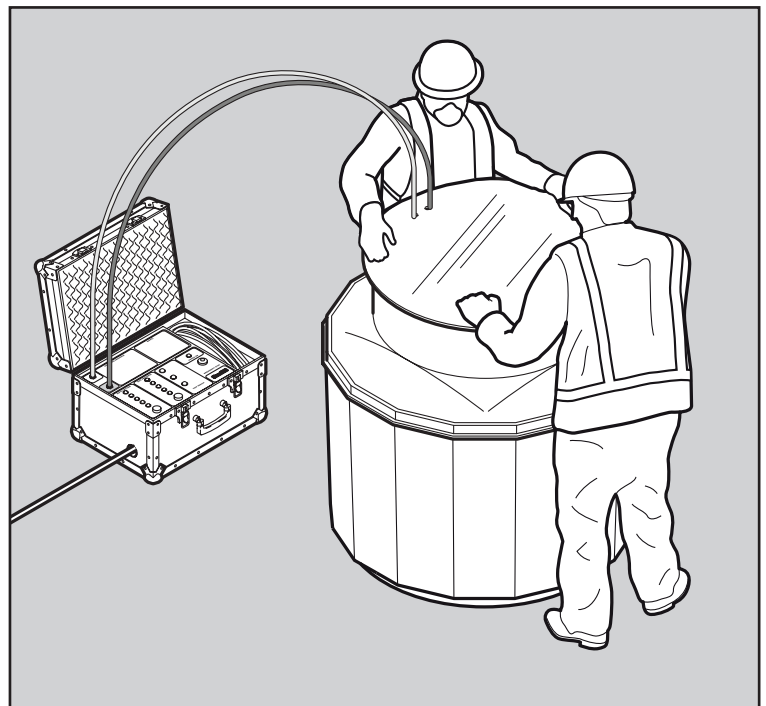

Fibrelite Multiport & Offset Fill Sump Systems (Critical Dimensions)



47

CRITICAL DIMENSION

All dimensions shown below are measured from a string line set at manhole grade level - for Wawa, this is 2" above tank pad grade level

Critical Dimension for Fill and Vapor Adaptors

Top of adaptor caps must be minimum 5" below grade. Top of adaptor or dry break coupling must be no more than 8" from grade

CRITICAL DIMENSION

From grade level to top of SS ring on sump tophat must be between 8" and 9"

CRITICAL DIMENSION

From grade level to top of sump riser must be 20"

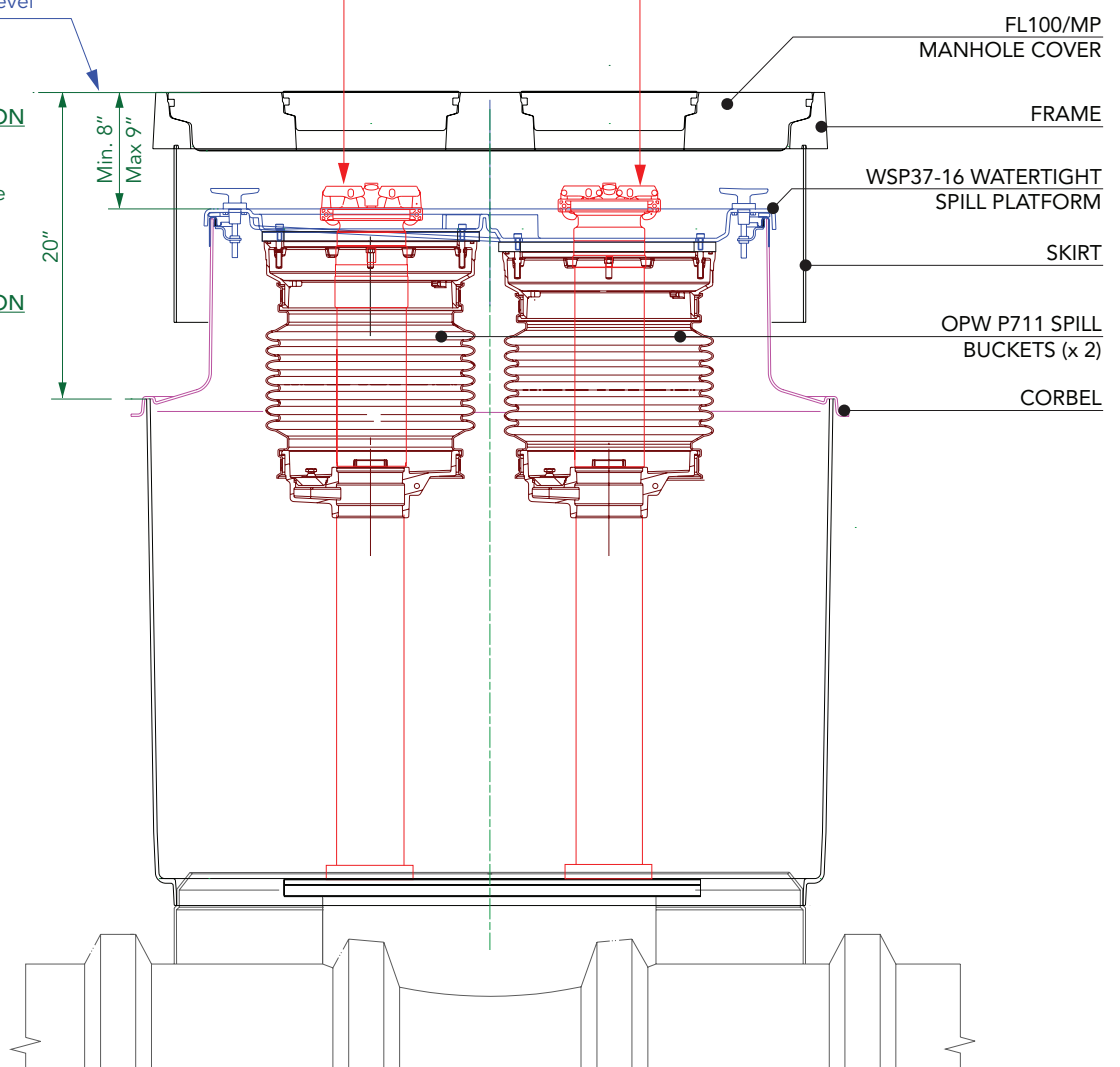

Fibrelite Multiport & Offset Fill Sump Systems (Backfilling)

48

Once the sump and corbel have successfully passed vacuum or hydrostatic tightness testing, the area around the sump can be carefully backfilled with peagravel or sand. Back-fill equally around the sump in layers to prevent damage or deformation.

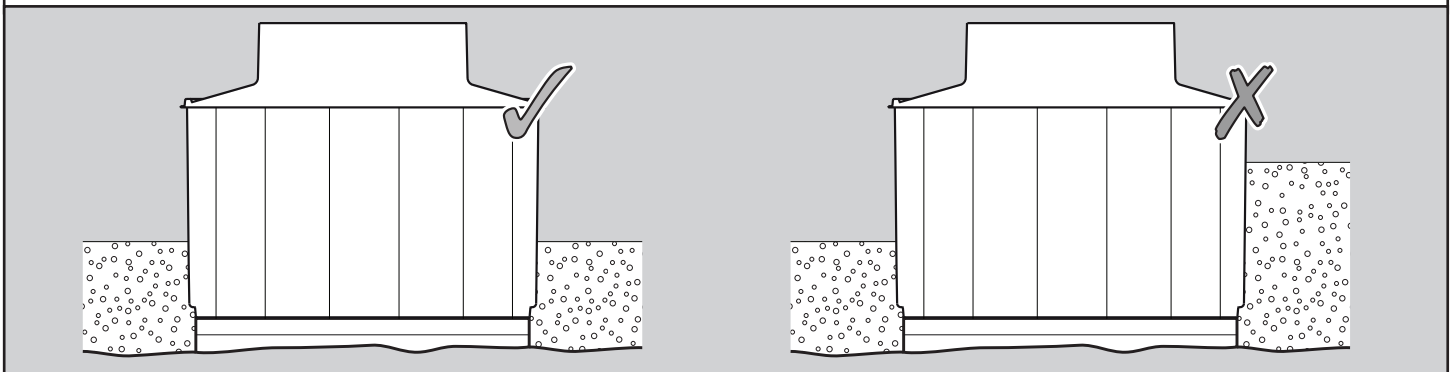

Fibrelite Multiport & Offset Fill Sump Systems

(Aligning/Installing the Skirt & Frame for Multiport and Offset Fill Covers)



49 After the sumps have been installed and backfilled, the multiport or offset fill covers can be installed.

The FL100/MP and FL100/OF frame need to be carefully installed to ensure that the fill and vapor port openings will line up properly above the risers. In order to position the frame so that the centerline of the fill and vapor ports are positioned directly over the fill and vapor risers, the FL100/MP frame must be positioned so that the centerline of one of the 15 flat facets on the frame is 180 degrees opposed from the edge or point of the opposite facet (as shown in the drawing below).

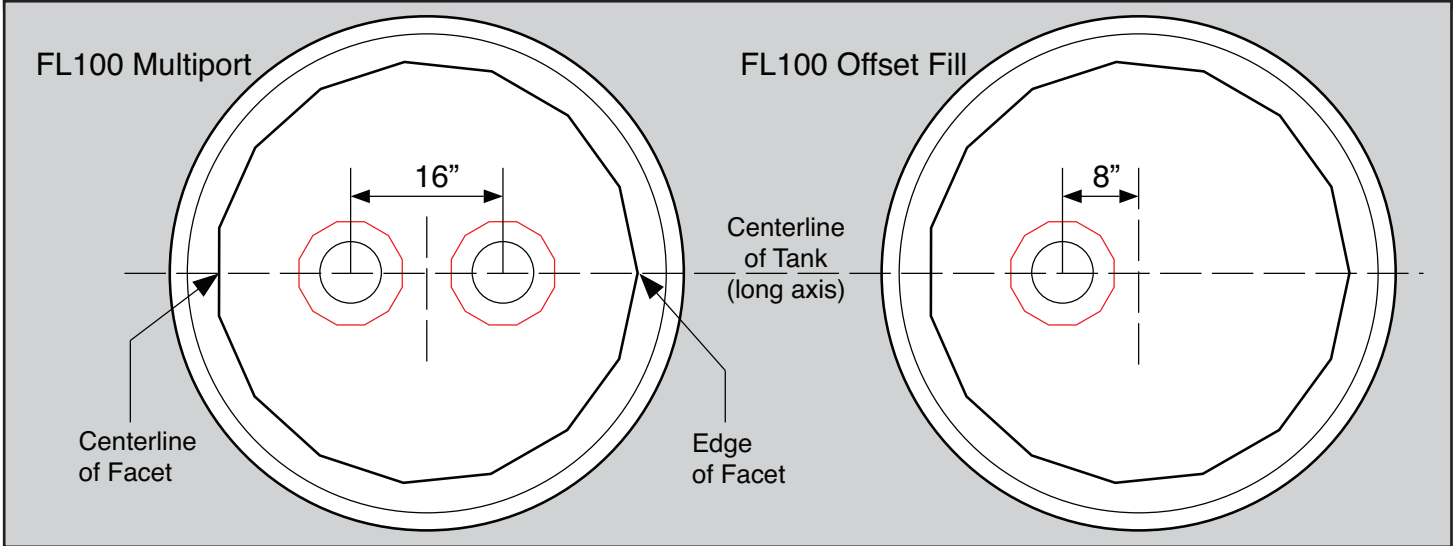

50 Fix a string line $\frac{1}{2}$ " above grade level across the sump, fix 4 hangers on the corbel top with base support facing out.

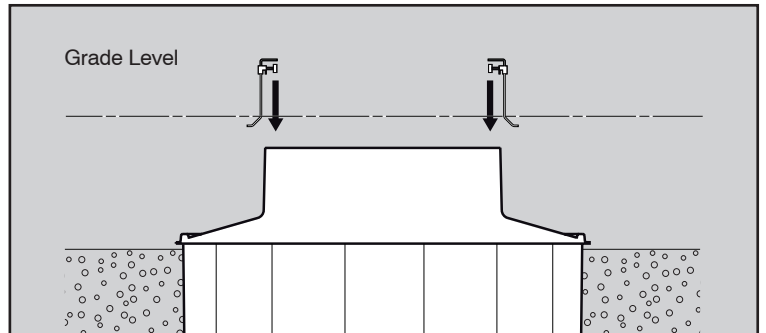

51 Put the skirt and frame on the hangers.

Locate the 4 foam blocks supplied between the skirt and corbel turret to centralise the skirt about the corbel. Failure to this may result in the internal lid fouling.

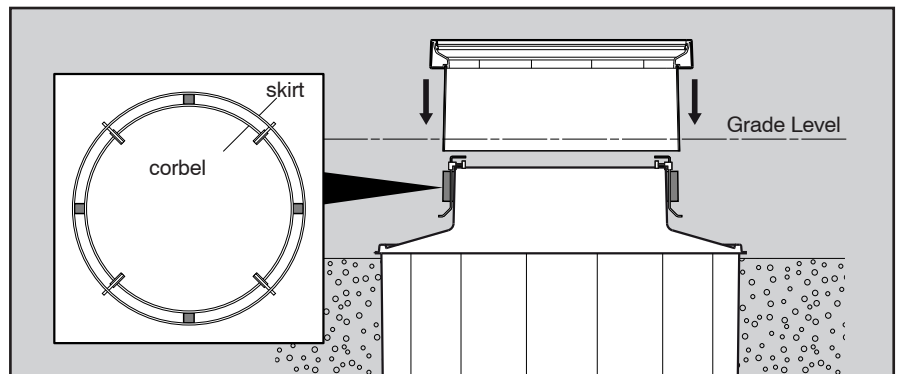

52 Adjust knobs to set the frame to stringline level, adjust for fall in grade. Set the frame $\frac{1}{2}$ " above grade level.

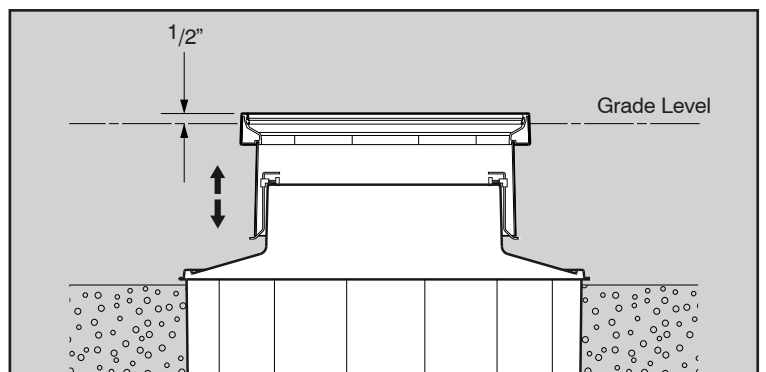

Fibrelite Multiport & Offset Fill Sump Systems (Concreting)



53 Ensure the void between corbel and skirt is kept free from concrete and a depth of 3 1/2" overlap minimum is maintained.

Ensure foam spacers are in position to locate the skirt centrally around the corbel.

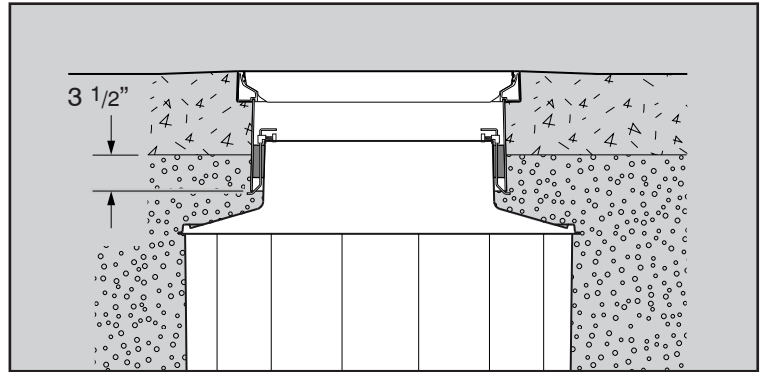

54 Complete backfilling to appropriate level. Frame must be supported by a minimum depth of 8" of concrete

Concrete reinforcement must be positioned as close to the frame as possible. Minimum block of 20" square around the frame. Joint must be tied as per diagram. Continuous pour preferred if possible.

VERY IMPORTANT

To allow for drainage, Fibrelite recommends that the concrete be sloped away from the top outer edge of the frame (A) a minimum of 1/2" over a 12" distance. Do not expose the top outer edge of the frame (A) – the concrete pad must be flush with the top outer edge of the frame.

TYPICAL INSTALLATION

CONCRETE

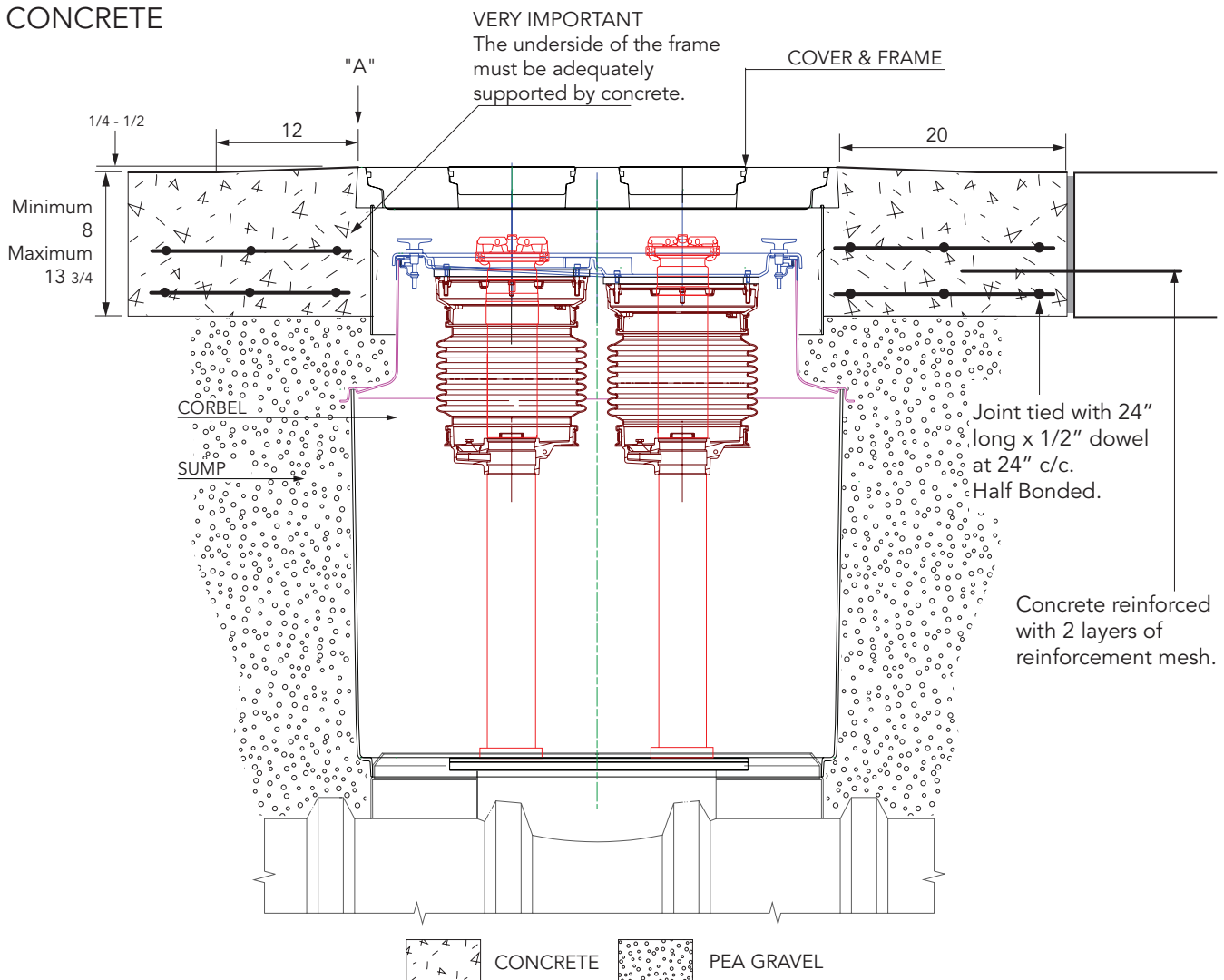

55 Ensure the void between corbel and skirt is kept free from concrete and a depth of 3 1/2" overlap minimum is maintained.

Ensure foam spacers are in position to locate the skirt centrally around the corbel.

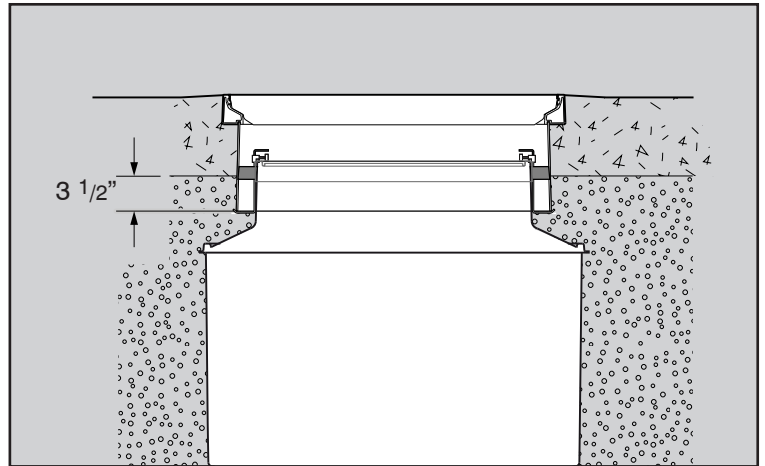

56 After minimum concrete cure time, hangers can be removed. Loosen the 'T' knob, push down on the rod, turn the rod through 90° and pull rod up to remove.

Complete other third party equipment installation inside the sump.

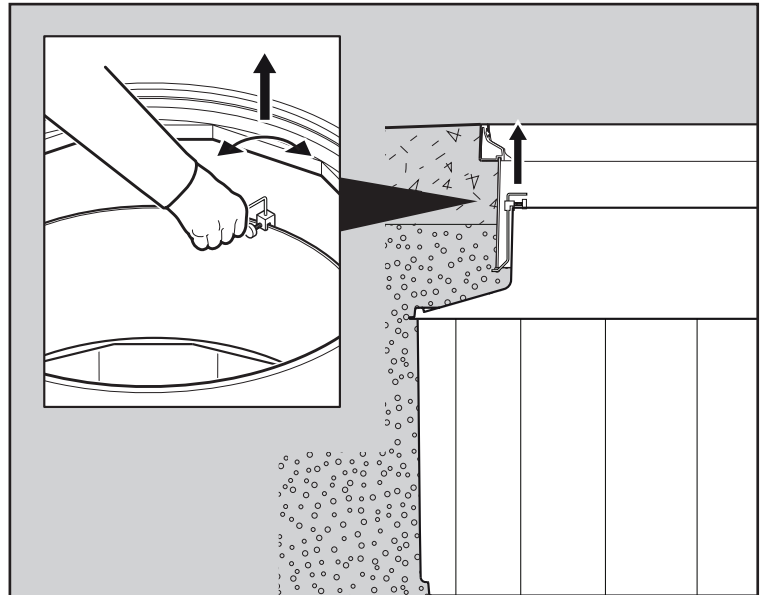

(Installation of Risers and Spill Buckets)

57 Installation of Risers and Spill Buckets: Once the tank sump and corbel with stainless steel ring has been installed so that there is a maximum 9" clearance from grade to the top of the stainless steel ring, it will be necessary to install the fill and vapor risers.

Note: It is critical that the length of the risers be set so that the top of the spill buckets are flush with or just slightly higher (approx. 1/2") than the top of the stainless steel ring. If spill buckets are set too high or too low, they will be difficult to connect to the underside of the watertight spill platforms.

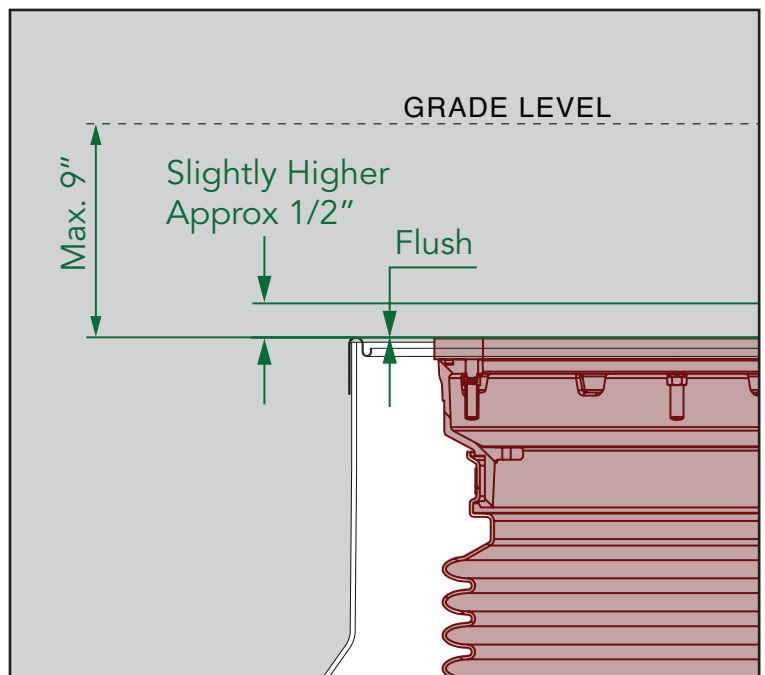

Fibrelite Multiport & Offset Fill Sump Systems (Installation of Risers and Spill Buckets)



58 Determining Riser Length = Distance from Grade to the Manway/Bung – Spill Bucket Height – Distance from Grade to top of Spill Platform + ½” + Thread Length.

In the example shown right, the fill riser length will be $51\ 1/2'' - 18'' - 9'' + 1/2'' = 27'' + \text{Threads}$.

Remember to add sufficient thread length on both ends.

Once the risers are set at the correct length, the spill buckets can be threaded onto the risers. If the spill buckets are not flush with or just slightly higher than the stainless steel retaining rings, it will be necessary to adjust the riser.

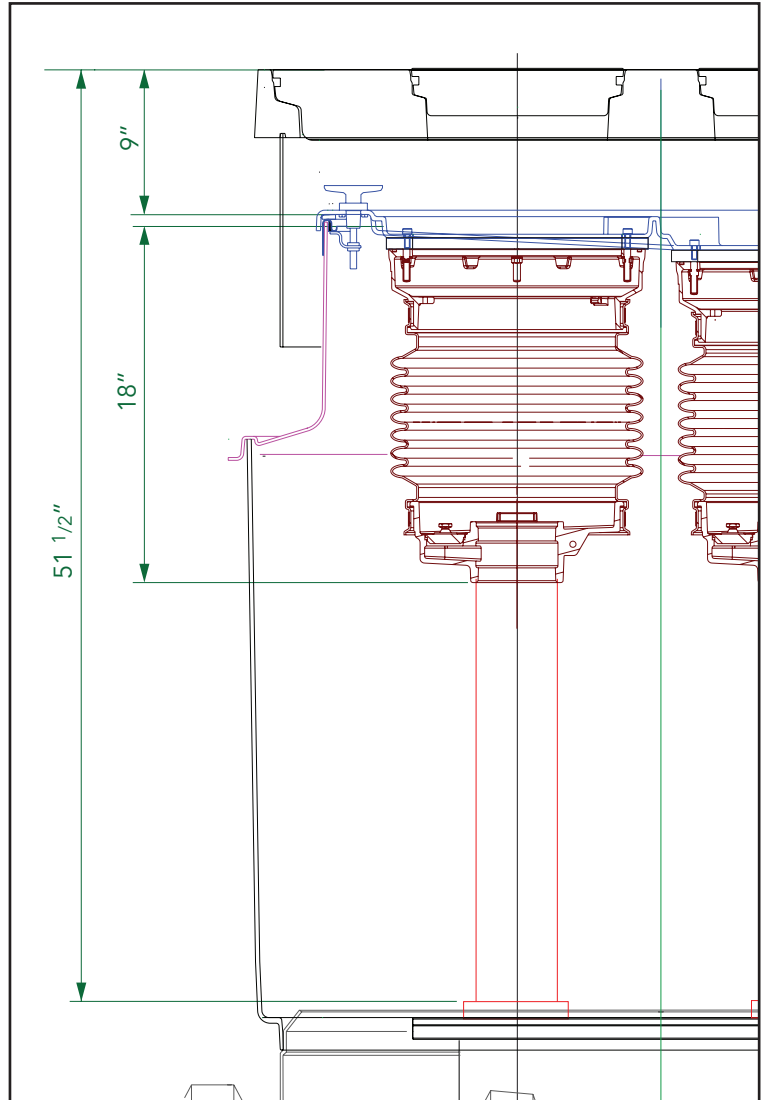

(S/CS/SEALANT - Corbel/Skirt Self Leveling Sealant)

59 The installation requires sealing off the backfill area from the spill bucket area (between the corbel and the skirt)

The S/CS/SEALANT will form a flexible, liquidtight barrier between the skirt and the tank sump corbel – thereby preventing any possible contamination into backfill.

Application Temperature: +32°F to +115°F
(Do Not apply at temperatures below +4°F)

Pot Life: 45 minutes at 80 °F
Storage Temp: +40°F to +70°F

Cure Times
Tack Free: 2 1/2 hours at 80 °F
Full Cure: 2 days

(Note: low temperatures retard cure, high temperatures accelerate the cure rate)

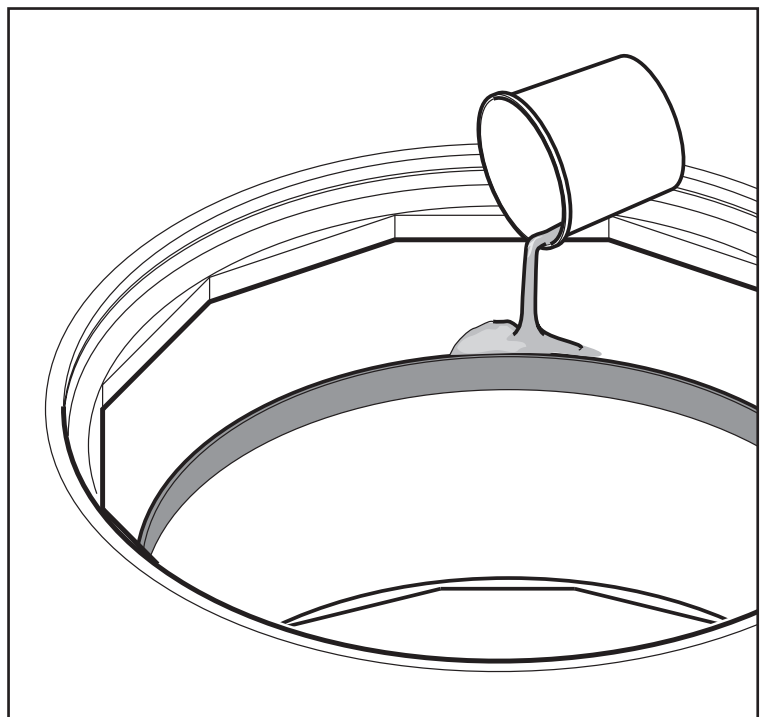

Fibrelite Multiport & Offset Fill Sump Systems (S/CS/SEALANT - Corbel/Skirt Self Leveling Sealant)



Safety Note: Gloves and goggles should be worn.

NB: Storage conditions: Store material in original containers in dry conditions within the temperature range +40°F to +70°F. The material must be protected from frost and direct sunlight. Prior to mixing ensure that the material shelf life has not expired. The material shelf life is 12 months from the date of manufacture, which is exhibited on the lid of each tin.

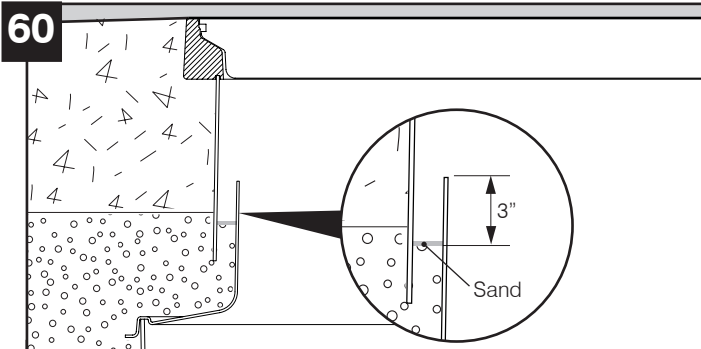

You must ensure that the void between the skirt and corbel is kept free from debris and concrete. Ensure that the base of the void is a minimum of 3" from the top of the corbel.

Apply a thin layer of sand at the base of the void.

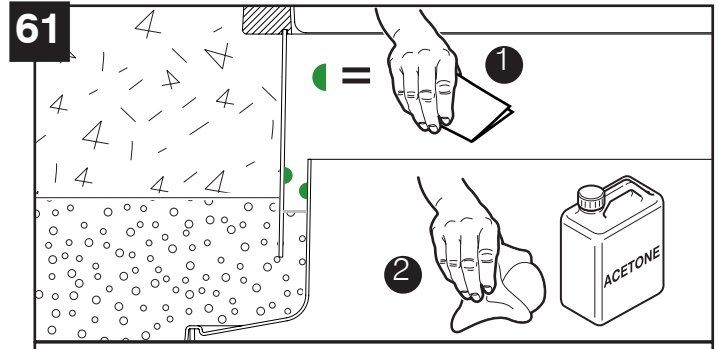

Thoroughly abrade the joint surface of the skirt and corbel. Degrease these surfaces with a suitable degreasing agent. The surfaces must be completely dry and free from all traces of dirt and grease.



The two part cold poured expansion joint sealant consists of one large tin (pack A) and one small tin (pack B). The combined contents of pack A & B are just over 1 US gallon.



Using a broad stick or paddle mixer, thoroughly stir the contents of pack A.



Stir in the COMPLETE liquid contents of pack B into the tin containing pack A, to give the combined content of just over 1 US gallon.

Note: It is not essential to stir in the white deposits from pack B as this is only a moisture inhibitor.

Note: If the moisture inhibitor has set hard then pack B may be contaminated with water and may result in the material not curing correctly.



Mix contents together for a full 5 minutes using a slow speed electric drill (400 - 500 rpm) with a low viscosity mixing paddle until a completely homogeneous mix is obtained. Mixing is made easier if pack B is added in two stages.

NB: Failure to use this type of paddle mixer may result in the material not being correctly mixed and therefore not curing correctly

Fibrelite Multiport & Offset Fill Sump Systems (S/CS/SEALANT - Corbel/Skirt Self Leveling Sealant)



66



Decant a suitable amount of mixed sealant into a smaller tin/pot (DO NOT USE THE TIN THAT CONTAINED PACK "B") and pour the mixed sealant into the void between the corbel and skirt.

67



The sealant (entire contents - just over 1 US gallon) should be poured into the void maintaining a minimum gap of 1 1/2" from the top of the corbel. Provided that the instructions have been followed (surface preparation, mixing and pouring of sealant) the results should be as per the above photo.

Fibrelite Multiport & Offset Fill Sump Systems (Installing Watertight Spill Platform)



Once the fill and vapor risers are properly installed and the spill buckets have been threaded onto the risers, the watertight spill platform should be installed to ensure that the buckets fit properly.

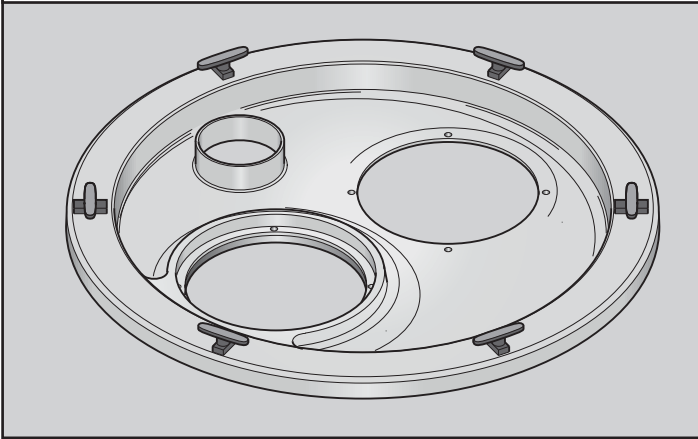

68 Install both spill buckets onto the risers. Turn all T-handles on the watertight platforms to the open position – the cam-lock latches on the underside should be 90 degrees opposed from the edge of the platform (as shown below):

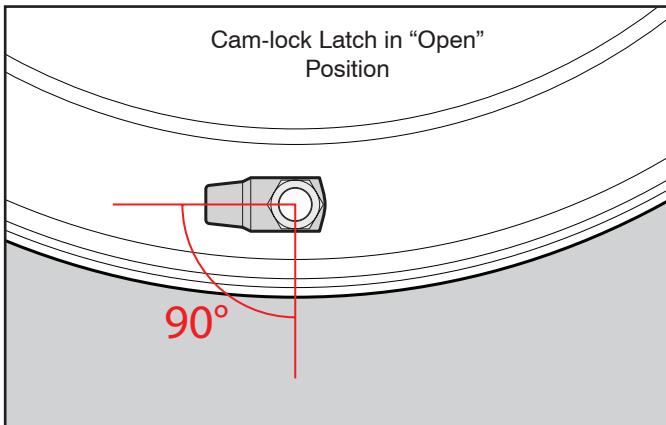
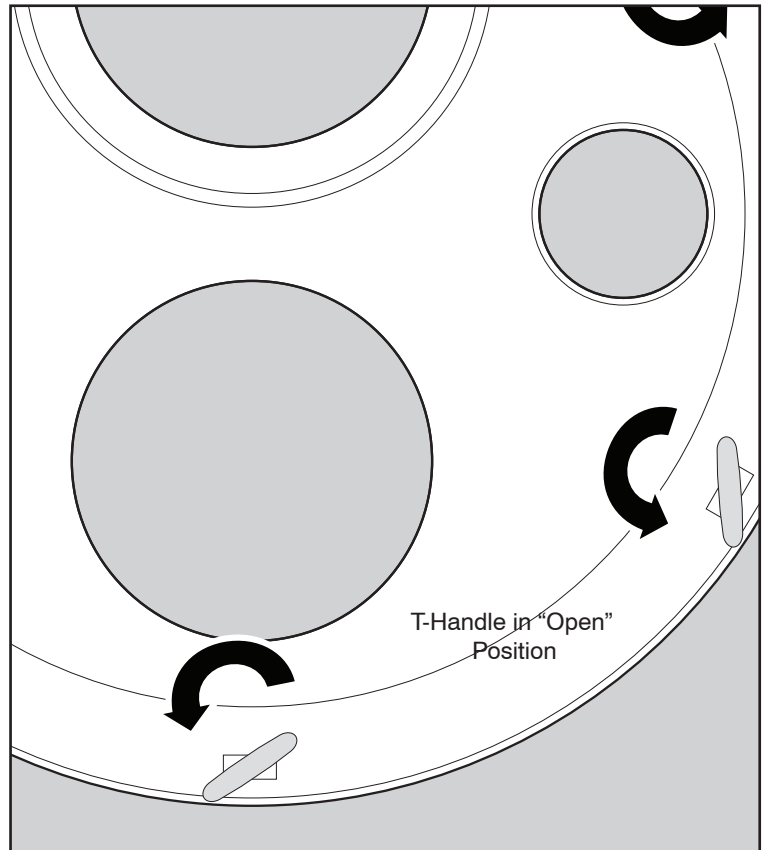

69 Seat the watertight spill platform on the stainless steel ring so that the 2 spill buckets sit immediately below the spill bucket openings. Press down on the platform if the buckets are slightly higher than the stainless steel locking ring. Locate the 6" diameter inspection port(s) as required. Turn the T-handles 90 degrees to lock the latch beneath the stainless steel ring (T-handle should be as shown as the image to the right).

If the T-handle fails to engage it may be necessary to adjust the 'cam-lock' height. See next page for adjustment instructions.

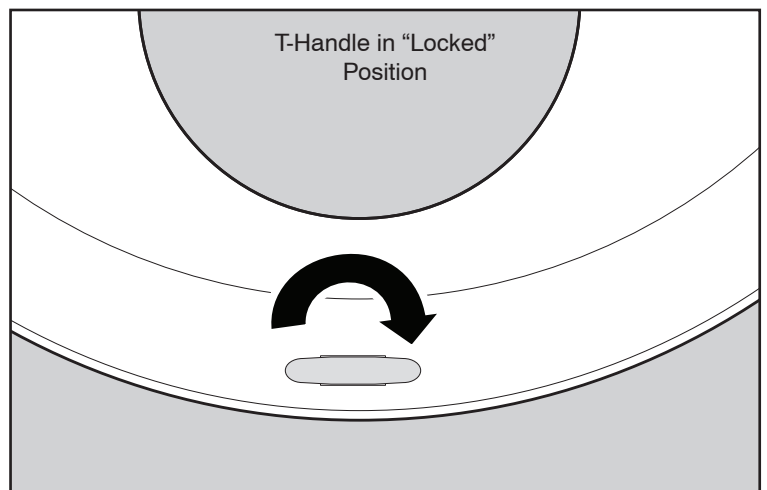

Fibrelite Multiport & Offset Fill Sump Systems (Adjusting the Cam-lock Height)

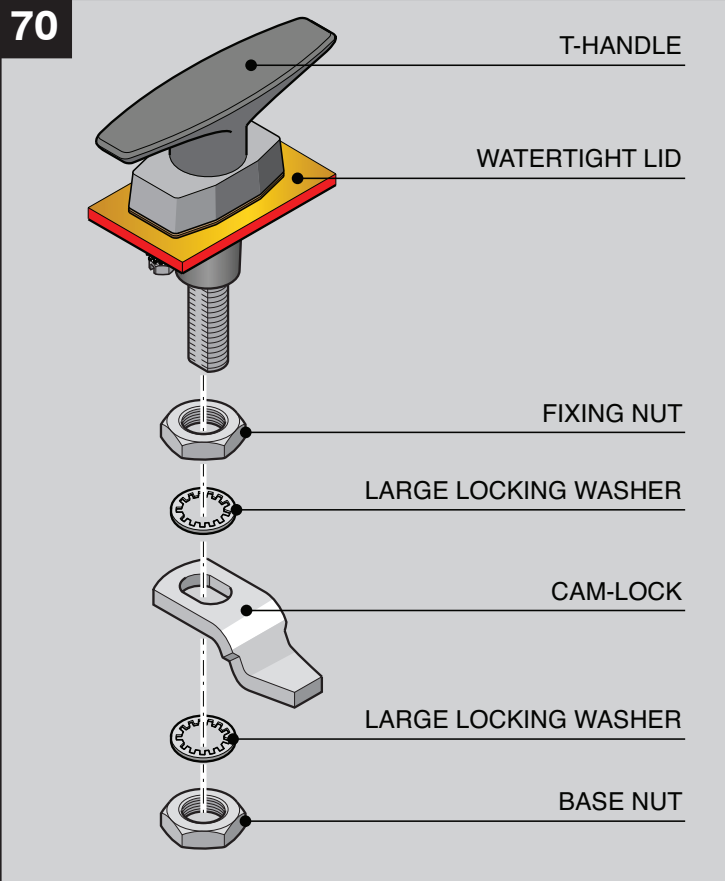

The T-handle mechanism consists of the above items.

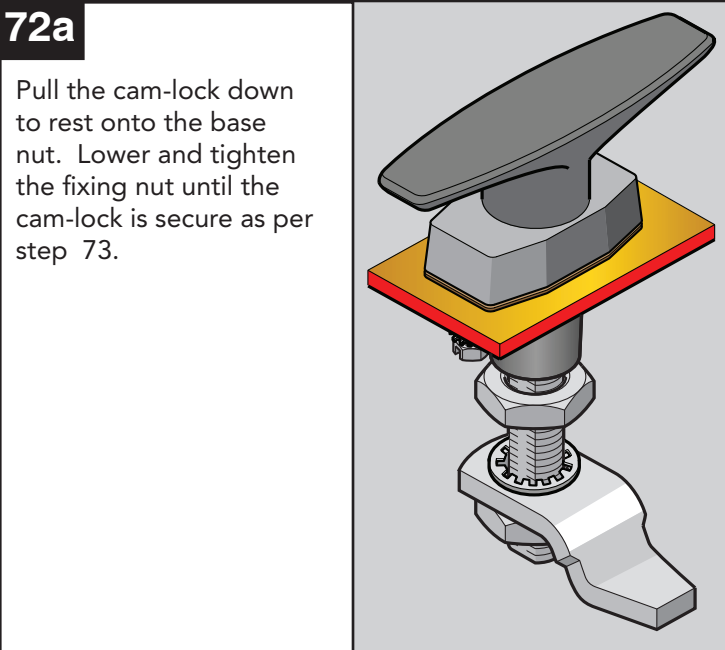

NOTE : If the T-handle cannot be fully engaged or if the lid is not compressing the gasket tightly against the stainless steel ring contact Fibrelite technical support.

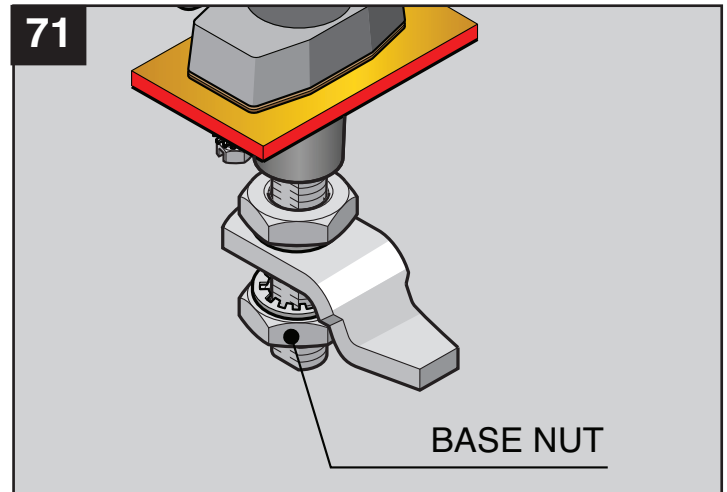

If the T-handle is not fully engaging it means the cam-lock needs to be lowered. Loosen the base nut to a lower position and go to step 72a.

If the lid is not compressing the gasket tightly against the stainless steel ring it means the cam-lock needs to be raised. Loosen the base nut and go to step 72b.

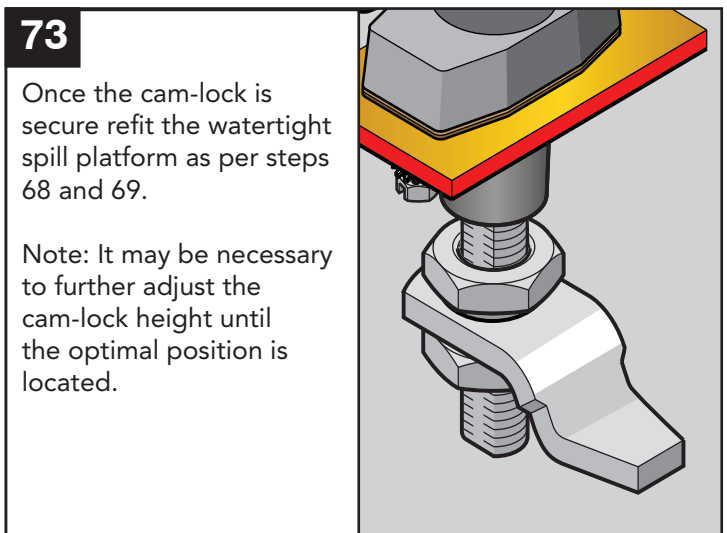
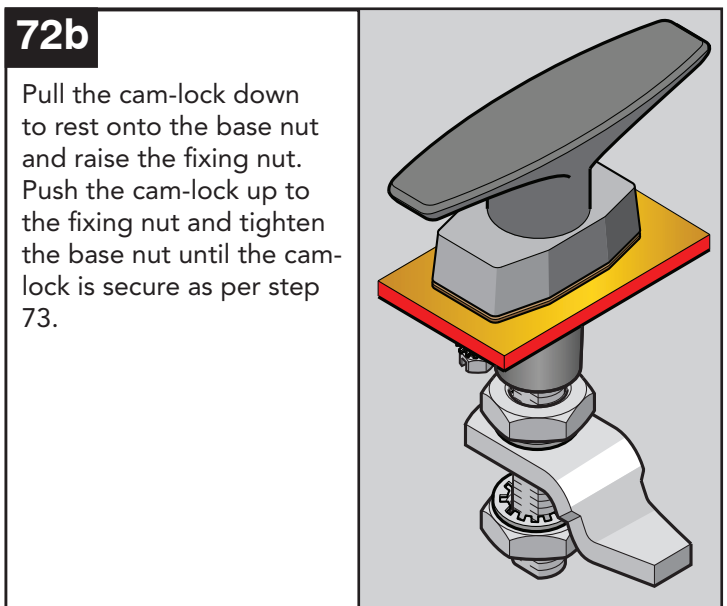

Fibrelite Multiport & Offset Fill Sump Systems (Connecting Spill Buckets to Watertight Spill Platform)



74 Once the spill buckets have been installed onto the risers and the watertight spill platforms are centered over the spill buckets, use the clamping ring assemblies to connect the spill platforms to the spill buckets. Each clamping ring assembly consists of (1) clamping ring and (2) "half moon" lower clamps (shown right).

If clamping rings do not line up easily over the bolts, it may be necessary to open up the holes using a step drill bit.

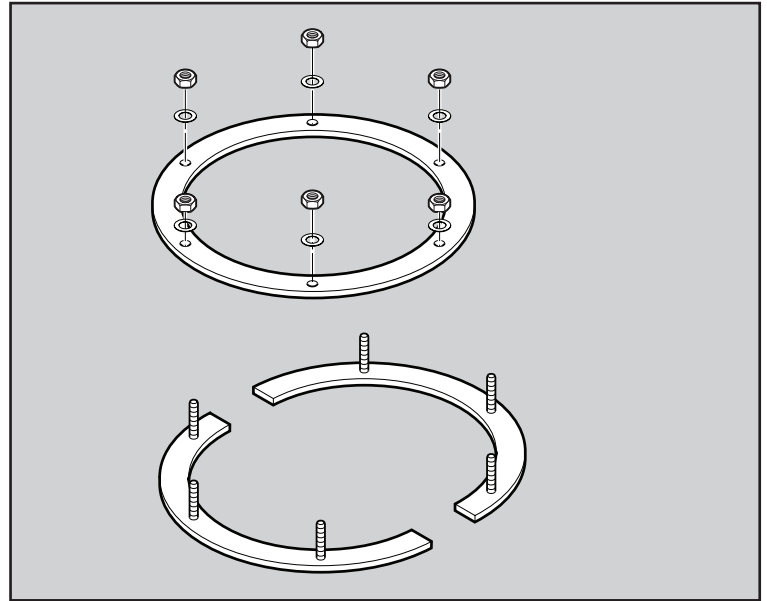

75 Install the clamping ring onto the lip of the spill platform opening into the spill bucket (as shown right).

The half-moon lower clamps should be installed one at a time. Push the spill bucket so that the upper lip of the spill bucket is flush beneath the platform hole. Place the half-moon lower clamp under the lip of the spill bucket so that the bolts on the clamp pass through the holes on the clamping ring.

Tighten a nut onto each of the lower clamp bolts using the 1/4-20 nut and lock-washer provided. Each nut should be fully tightened so that the gasket under the platform is fully compressed and sealed between the top of the spill bucket and the underside of the platform.

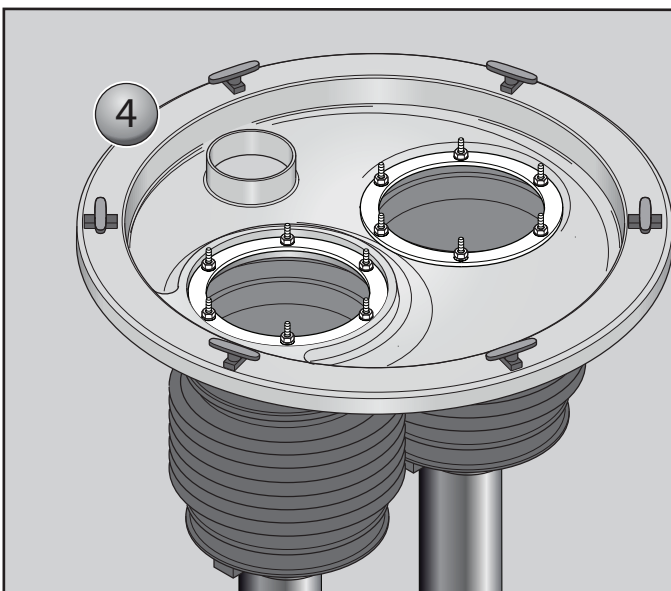
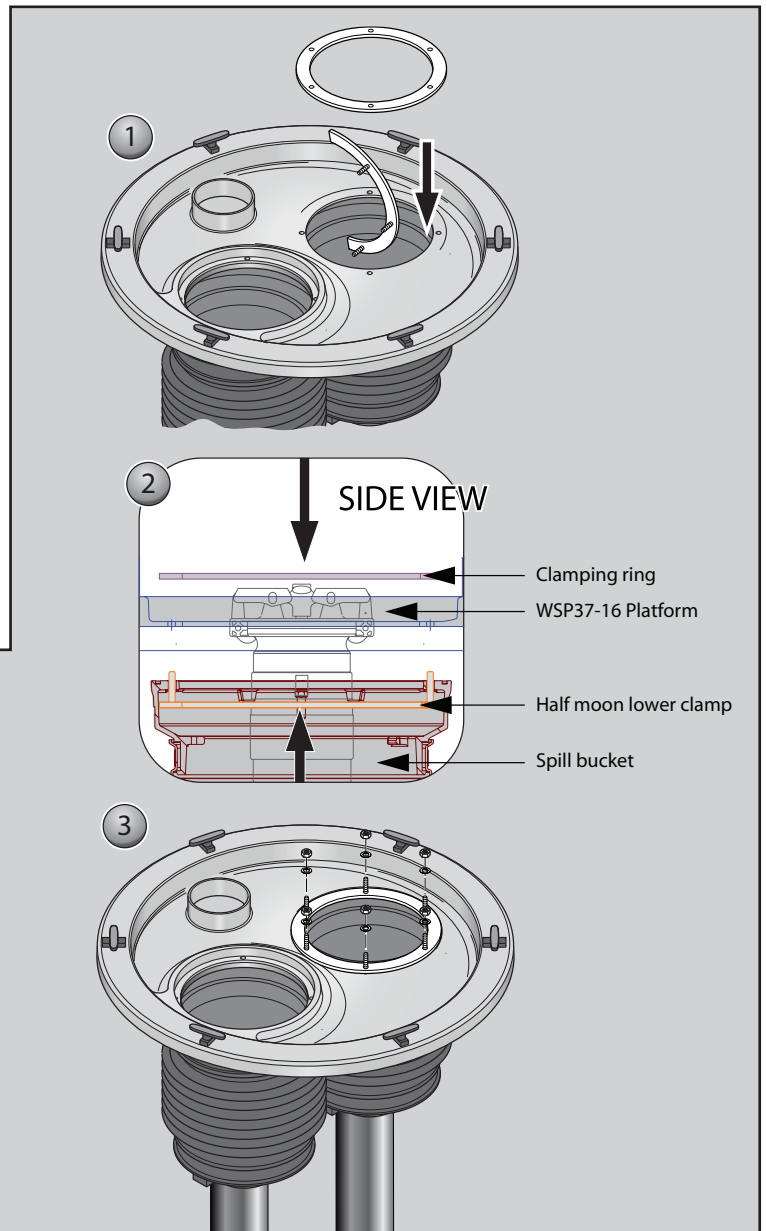

Fibrelite Multiport & Offset Fill Sump Systems (Inspection Ports)



76 As shown in the image to the right the standard watertight spill platform is equipped with a single 6" inspection port. After installing the clamping rings, ensure that the clamp is tight so that the inspection port fitting does not slip off. Tighten it with a screwdriver or 1/4" socket if required.

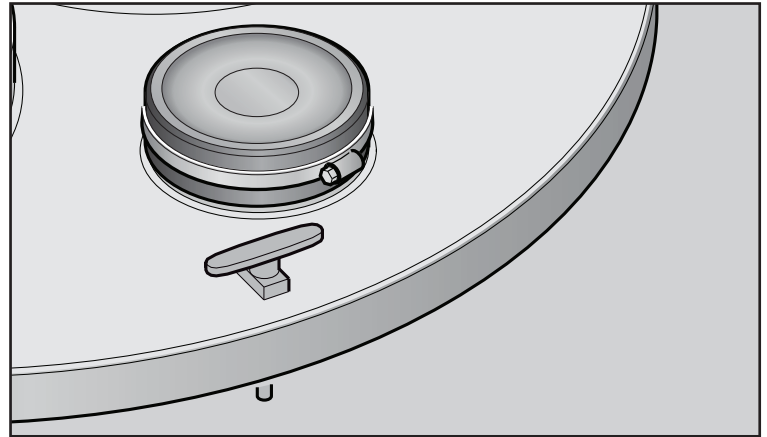

(Installing Swivel and Vapor Recover Adaptors)

77 The top of the swivel adaptor or dry break coupling should be positioned no more than 8" below grade to allow for drivers to connect their nozzles. The top of the adaptor caps must be at least 5" from grade to prevent the fill or vapor port covers bottoming out on the cap.

Critical Dimension for Fill and Vapor Adaptors
Top of adaptor caps must be minimum 5" below grade. Top of adaptor or dry break coupling must be no more than 8" from grade

