

IMPORTANT: Please read all warnings and follow the installation instructions completely and carefully. Failure to do so will void all warranties and may cause product failure, or result in environmental contamination due to liquid leakage into the soil, creating hazardous spill conditions.

WARNING - DANGER: Using electrically operated equipment near gasoline or gasoline vapors may result in a fire or explosion, causing personal injury and property damage. Be sure that the working area is free from such hazards, and always use proper precautions.

Notice: OPW products must be used in compliance with applicable federal, state, and local laws and regulations. Product selection should be based on physical specifications and limitations and compatibility with the environment and material to be handled. All illustrations and specifications in this literature are based on the latest production information available at the time of publication. Prices, materials, and specifications are subject to change at any time, and models may be discontinued at any time, in either case, without notice or obligation.

OPW FlexWorks Fuel Oil Piping Systems are designed to provide a reliable, secondarily contained, underground fuel supply system to generators and boilers from remote fuel tanks. Typical applications include a 3/4" or 1" supply and a 1" overflow return line running from a remote AST or UST to a generator engine or boiler Day Tank. The underground piping runs typically includes FlexWorks supply and return lines inserted within a common 4" FlexWorks Access pipe to provide retractable access to, and containment of, the fuel lines. FlexWorks Fuel Oil Pipes are designed to be installed underground and contained within FlexWorks Access Pipe. The transition to above grade metallic piping is made either in a FlexWorks Above/Below Grade Transition Sump or through a concrete slab with a FlexWorks Fuel Oil Pipe Transition Assembly (PTA-4175). All underground connections must be contained within a FlexWorks Tank Sump or Transition Sump (See Assembly Diagrams on following pages).

I) Piping Trench and Pipe Burial Requirements

IMPORTANT: FlexWorks Fuel Oil Piping Systems must be installed in accordance with all prevailing Federal, State, and Local codes and all applicable FlexWorks Installation Instructions.

Piping Trench Requirements

Piping trenches should be dug in such a manner that the trench width is equal to at least twice the width of all the flexible pipes contained within. All piping within the trench should be separated by the outside diameter of the piping being installed with a required minimum of 2" (50 mm) of separation for all piping. Trench turns should be sweeping

rather than sharp angles. The bottom of the trench should be compacted and as uniform as possible to eliminate high spots to insure an even layer of bedding material under the pipe. Remove all sharp rocks and debris from the trench bottom before bedding material is installed.

Piping Burial Requirements

1. **Unpaved Surfaces** - If the surface is unpaved, then a minimum of 18" (457mm) of approved backfill material should be installed between the top of all flexible piping and the top of the ground surface.
2. **Paved Surfaces** - If the surface is paved with either asphalt or concrete, the total amount of pavement plus approved backfill material shall be a minimum of 18" (457mm) between the top of either the flexible piping and the top of the paved surface.
3. **Access Pipe Burial** - Whether the surface is paved or unpaved with either asphalt or concrete then there shall be a minimum of 16" (406mm) between the top of the Access Pipe and the top of the paved or unpaved surface.

Approved Bedding & Backfill Materials

Approved bedding and backfill materials for OPW-FCS's flexible piping sumps and Access piping shall meet the following specifications:

1. **Pea Gravel** - Rounded Pea Gravel is permitted with a minimum diameter of 1/8" and a maximum diameter of 3/4".
2. **Crushed Stone** - Crushed stone is permitted providing it shall be washed clean and be of the free flowing type with an angular stone size between 1/8" and 1/2". (Meets ASTM C-33 paragraph 9.1 requirements.)
3. **Sand** - Sand backfill is permitted providing it shall be washed clean and is free flowing with a maximum content of 10% fines. When backfilling, make sure sand is evenly distributed and fully compacted under and fully around the piping.

NOTE: A minimum of 6" (152mm) of approved bedding material shall be spread and compacted evenly along the bottom of the piping trench. All bedding and backfill material should be clean and free from ice and snow and debris. Using material other than those described above without written approval from OPW Fueling Containment Systems will void the product warranty.

II. System Installation

FlexWorks retractable Fuel Oil Piping Systems consist of FlexWorks primary pipe fuel oil pipe runs installed in FlexWorks corrugated Access Pipe.

Retractable systems utilize Access Pipe to allow the pri-

mary pipe and couplings to be removed in the future for inspection, repair, or replacement without excavating or breaking concrete.

The Access Pipe is installed first between containment sumps or between a sump and a Transition Assembly that is used when the pipe is run through a concrete slab. The primary pipe is then inserted through the Access Pipe.

FlexWorks Piping is shipped in continuous rolls and is typically measured and cut to length at the job site. Pipe must be protected from damage before and during installation.

Step #1 - Prepare Trenches: Prepare Trenches in accordance with the requirements listed in the previous section.

Step #2 - Set Sumps:

Set FlexWorks Tank Sumps and Above Grade/Below Grade Piping Transition Sumps as required. See typical installation diagrams (Refer to individual FlexWorks Tank Sump and Transition Sump Installation Instructions).

- FlexWorks Tank Sumps are mounted on top of underground storage tanks to contain the pipe entries into the tank. Tank Sumps are available in various heights and are field adjustable to accommodate varying tank burial depths. Tank sumps are also available in diameters for use with both 36" and 42" manholes.
- FlexWorks Transition Sumps are used to contain and maintain access to the pipe fittings where the pipe transitions between the flexible pipe below grade and rigid pipe above grade. Transition Assembly is also available for use where the pipe comes through a concrete slab.

IMPORTANT: Support all sumps with adequate backfill up to the bottom of the pipe entry fittings. Make sure no voids are present under the sumps. Make sure 1/8" per foot minimum slope is maintained from the last dispenser sump in each piping run back to the tank.

Step #3 - Install Entry Fittings:

Install 4" FlexWorks Entry Fittings as required in FlexWorks Transition Sumps and Tank Sumps. (Refer to individual FlexWorks Entry Fitting Installation Instructions).

Step #4 - Install Pipe and Pipe Couplings:

- Install FlexWorks piping according to the guidelines found in the OPW Fueling Containment Systems **Flexible Underground Piping Manual** (Publication UPM-0001).
- Cut the pipe using a FlexWorks Pipe Cutting Tool (PCT-1000).
- Be careful not to kink the pipe. Check each section for damage before installation.

Step #5 - Install Pipe Couplings:

Using the FlexWorks Coupling Machine (CME-0110), attach the pipe couplings to each end of each pipe section (Refer to individual Installation Instructions supplied with the Cou-

pling Machine).

1. When Coupling 3/4" and 1" pipe, use the following swage kits - CSK-0075S (3/4" pipe) and CSK-0100S (1" pipe).
2. Unscrew the shaft from the Coupling Machine (CME-0110).
3. Insert the shaft for either the 3/4" or 1" pipe.
4. Place the 1.5" Swivel Faceplate (EG-CM-0170) on the Coupling Machine.
5. Place the 3/4" or 1" Faceplate on top of the 1.5" Swivel Faceplate.
6. Screw in the 3/4" or 1" Swage on the shaft.
7. Follow the instructions in the OPW Fueling Containment Systems **Flexible Underground Piping Manual** (Publication UPM-0001) for proper procedures for coupling the pipe.

Step #6 - Test the Access Pipe if Needed:

Connect a regulated air supply with a gauge to the air stem on the TBA-4175A. Carefully pressurize the Access Pipe through the air stem on the Test Boot (TBA-4175). (2 psig is customary; do not exceed 5 psig). Leave each line pressurized for one hour. Loss of pressure signifies a leak in the line that must be corrected before proceeding.

Step #7 - Sump Testing:

After all connections are made, fill the sumps with water 1" above the highest penetration fitting. A drop in the water level within 1 hour indicates a leak that must be corrected before backfilling.

Step #8 - Backfilling:

Rounded pea gravel with a minimum diameter of 1/8" and a maximum diameter of 3/4" should be used for backfill around sumps.

IMPORTANT: If installing Transition sumps in high water table areas, use pea gravel inside transition sumps as ballast to prevent the sump from floating up. A slotted pipe can be installed in one corner of the sump to allow monitoring for and removal of contained liquid.

Maintenance

OPW Sumps are designed to provide secondary containment of dispensers and piping connections. Sumps should be regularly inspected and checked for the presence of petroleum products. Damage or leaks in piping, sumps, and fittings should be repaired promptly. Third party approved liquid sensors should be installed in every sump. Any liquid present in the sump should be promptly removed and disposed of properly.

AST Applications

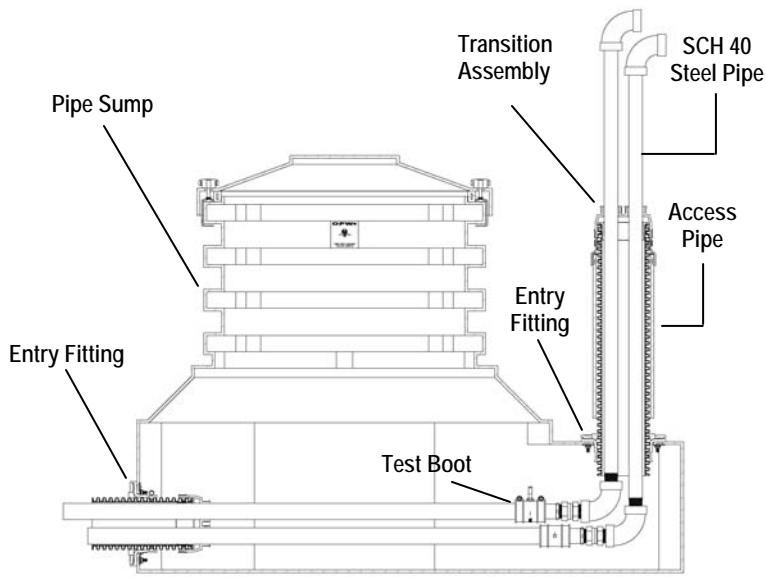

AST Applications

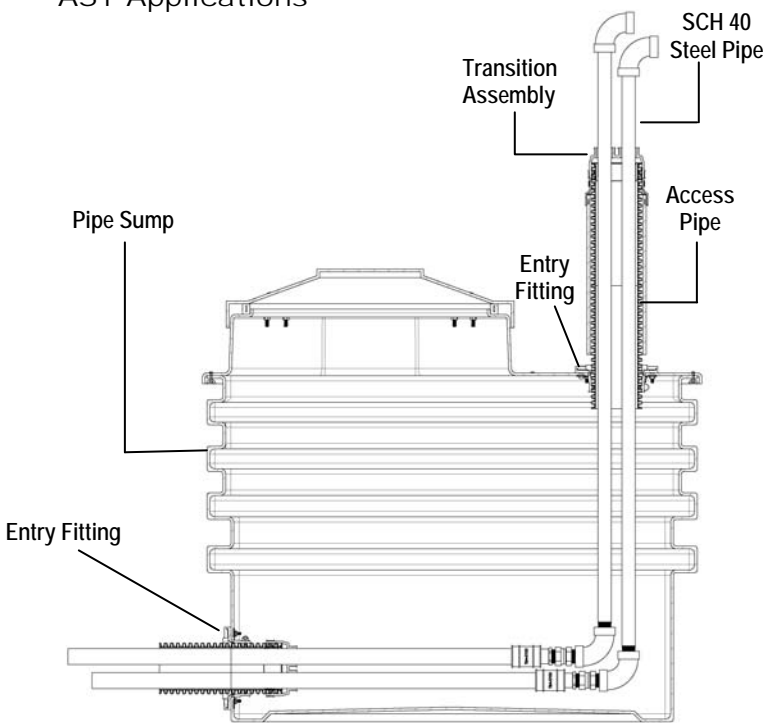

Transition Sump Assembly

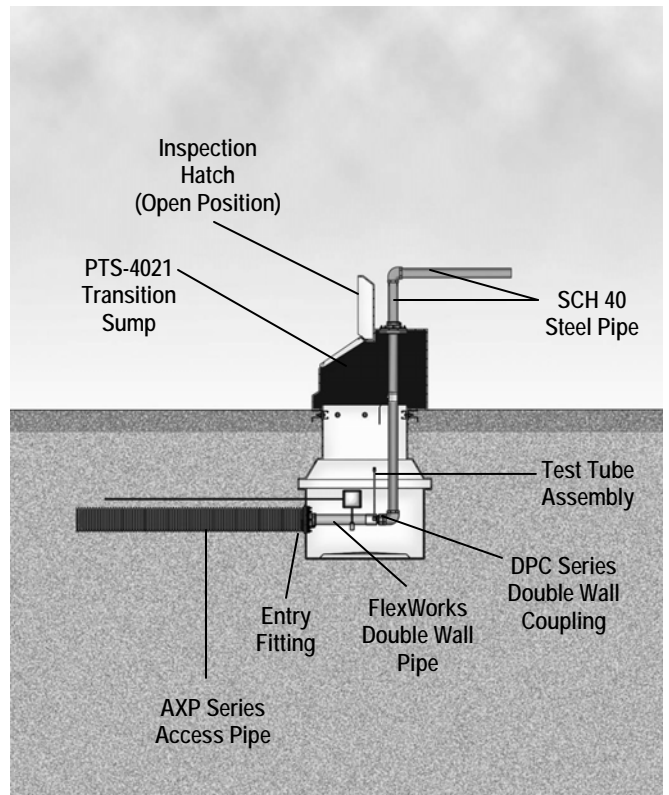

NOTICE: FlexWorks by OPW, Inc., VAPORSAVER™ and all other OPW products must be used in compliance with all applicable federal, state, provincial and local laws, rules and regulations. Product selection is the sole responsibility of the customer and/or its agents and must be based on physical specifications and limitations, compatibility with the environment and material to be handled. All illustrations and specifications in this literature are based on the latest production information available at the time of publication. Prices, materials and specifications are subject to change at any time, and models may be discontinued at any time, in either case, without notice or obligation.

OPW warrants solely to its customer that the following products sold by OPW will be free from defects in materials and workmanship under normal use and conditions for the periods indicated:

OPW's exclusive obligation under this limited warranty is, at its option, to repair, replace or issue credit (in an amount not to exceed the list price for the product) for future orders for any product that may prove defective within the applicable warranty period. (Repairs or replacements are subject to prorated warranty coverage for remainder of the original warranty period). Complete and proper warranty claim documentation and proof of purchase required. All warranty claims must be made in writing and delivered during the applicable warranty period to OPW at OPW 9393 Princeton-Glendale Road Hamilton, Ohio, USA 45011, Attention: Customer Service Manager. No products may be returned to OPW without its prior written authority.

This limited warranty shall not apply to any FlexWorks or VAPORSAVER™ product unless it is installed by an OPW attested installer. This limited warranty also shall not apply to any FlexWorks, VAPORSAVER™ or other OPW product: unless all required site and warranty registration forms are

PRODUCT	WARRANTY PERIOD
FlexWorks Primary Pipe	10 years from date of manufacture
All Products Certified to California 2001 Standards*	1 year from date of manufacture or from date of installation registration (not to exceed 15 months from date of manufacture)
All other Products	1 year from date of manufacture

**Products certified to California 2001 Standards will have an OPW Registration Card enclosed/attached to the product.*

completed and received by OPW within 60 days of installation; unless all piping connections are installed with a nationally-recognized or state-approved leak detection device in each tank and dispenser sump (which are not for storage and from which all discharge hydrocarbons must be removed, and the systems completely cleaned, within 24 hours); unless testable sumps utilize FlexWorks pipe and access fittings; unless a sump inspection log or an EPA recommended/required checklist is maintained and the results are furnished to OPW upon request; and unless OPW is notified within 24 hours of any known or suspected product failure and is provided with unrestricted access to the product and the site. This limited warranty also shall not apply to any product which has been altered in any way, which has been repaired by anyone other than a service representative authorized by OPW, or when failure or defect is due to: improper installation or maintenance (including, without limitation, failure to follow FlexWorks Quick Reference Manual Installation Guide and all product warning labels); abuse or misuse; violation of health or safety requirements; use of another manufacturer's, or otherwise unauthorized, substances or components; soil or other surface or subsurface conditions; or fire, flood, storm, lightning, earthquake, accident or any other conditions, events or circumstances beyond OPW's control.

THIS LIMITED WARRANTY IS IN LIEU OF ALL OTHER WARRANTIES, EXPRESS OR IMPLIED, AND ALL OTHER WARRANTIES INCLUDING, WITHOUT LIMITATION, THE WARRANTIES OF MERCHANTABILITY AND FITNESS FOR A PARTICULAR PURPOSE, ARE HEREBY EXCLUDED.

OPW shall have no other liability whatsoever, whether based on breach of contract, negligence, gross negligence, strict liability or any other claim, including, without limitation, for special, incidental, consequential or exemplary damages or for the cost of labor, freight, excavation, clean-up, downtime, removal, reinstallation, loss of profit, or any other cost or charges. No person or entity is authorized to assume on behalf of OPW any liability beyond this limited warranty. This limited warranty is not assignable.



OPW Fueling Containment Systems
3250 US 70 Business West
Smithfield, NC 27577
Customer Service: (800)-422-2525
Customer Service Fax: (800)-421-3297
Technical Questions: (877)-679-8324
www.opwglobal.com

Part Number:	H14694M
Issue Date:	08-10-2011
Supersedes:	12-12-2000