



## OPW Installation and Maintenance Instructions

### OPW 1DK-2100 EVR Replacement Drain Valve

**IMPORTANT:** Please read these warnings and use the assembly instructions completely and carefully before starting. Failure to do so may cause product failure, or result in environmental contamination due to liquid leakage into the soil, creating hazardous spill conditions.

**IMPORTANT:** Check to make sure the unit is intact and undamaged and all parts have been supplied. Never substitute parts for those supplied. Doing so may cause product failure and void warranty.

**WARNING-DANGER:** Using electrically operated equipment near gasoline or gasoline vapors may result in a fire or explosion, causing personal injury and property damage. Be sure that the working area is free from such hazards, and always use proper precautions.

**NOTE:** At all times when product is in the storage tank keep the riser pipe capped, so the vapors cannot escape into the environment.

The OPW 1DK is an optional drain valve replacement kit for the OPW 1 Spill Container Series. It is designed to return incidental spillage of liquid back to the underground storage tank.

### HOW TO INSTALL

1. Remove and discard existing drain valve and O-ring.
2. Clean any dirt or debris from the sealing surface where the new drain valve will be installed.
3. Apply any common grease or light oil to the new supplied O-ring. Assemble the O-ring into the spill container base.
4. Insert the 1DK into the spill container O-ring. Be sure that the drain valve seats flush with the floor of the spill container base.
5. The pull lever of the 1DK **MUST** be positioned halfway between the riser pipe nipple and the spill container bellows. Rotate the drain valve until that position is attained.
6. Secure the 1DK by installing the provided retaining clips and nuts. Tighten the nuts to a torque of 11.5 ft-lbs min. to 13.5 ft-lbs max.
7. The drain valve is now installed and ready for testing.

### HOW TO TEST

Upon preliminary installation perform the California Test Procedures TP-201.1C or equivalent. These Test Procedures will check the seals between the drain valve, nipple and rotatable adaptor. To test the spill containers base and bellows fill the container with water. A drop in the water level of 1/16" or more after one hour means that a leak exists. To determine where the leak is, look for a steady stream of bubbles coming from one of the joints.

**NOTE:** Do not drain the water into the UST after the test is complete. Water must be disposed of per local requirements for hazardous waste.

If a leak is observed in the Test Procedure, check to see that the drain-valve poppet is sealing properly. To do this, lift up the drain-valve pull chain several times to actuate the poppet. This will ensure that the drain-valve poppet is seating properly. If this doesn't correct the leak remove the 1DK valve and inspect the O-ring for nicks or tears, replace if needed; also clean the sealing surfaces of the spill-container base that the 1DK valve and O-ring are installed into. Reinstall 1DK valve and repeat test.

If spill container passes the Test Procedure but does not hold water then there is a leak in the bucket and it will need to be replaced.

### Alternative Construction

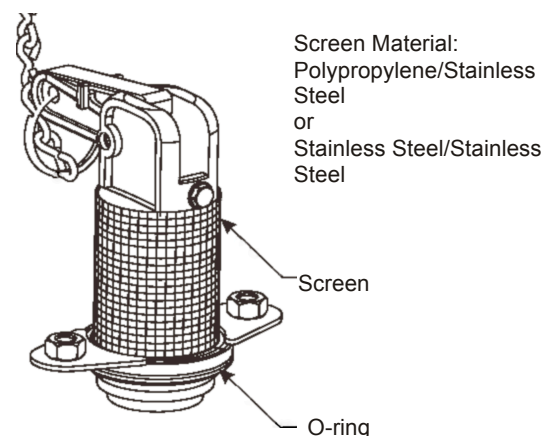

## 1DK-2100 EVR Replacement Drain Valve Performance Specifications:

This Spill Container drain valve has been manufactured and tested to the following California specifications: Leak Rate to be less than or equal to 0.17 CFH @ 2.0" W.C.

### Operation and Maintenance:

To open, pull drain valve chain up and hold open until liquid is drained. To close, release chain.

### Annually:

Inspect and clean the interior of the spill container and drain valve screen. Remove accumulated dirt and grit. Test the drain valve using CARB procedure TP-201.1C or TP-201.1D. If the drain valve passes testing no further maintenance is required. If the drain valve fails testing, remove the valve, soak in water and use high-pressure air, if needed, to clean. Reinstall the drain valve to its proper position and test the valve with CARB procedure TP-201.1C or TP-201.1D.

<b>Important:</b> Leave these instructions with the Station Operator.
---

### NOTICE:

OPW products must be used in compliance with applicable federal, state, and local laws and regulations. Product selection should be based on physical specifications and limitations and compatibility with the environment and material to be handled. OPW makes no warranty of fitness for a particular use. All illustrations and specifications in this literature are based on the latest production information available at the time of publication. Prices, materials, and specification are subject to change at any time, and models may be discontinued at any time, in either case, without notice or obligation.

### Standard Product Warranty

*OPW warrants that products sold by it are free from defects in materials and workmanship for a period of one year from the date of manufacture by OPW (ECO products two years from date of manufacture.) Proof of purchase may be required. As the exclusive remedy under this limited warranty, OPW will, at its sole discretion, repair, replace, or issue credit for future orders for any product that may prove defective within the one-year date of manufacture period (repairs, replacements, or credits may be subject to prorated warranty for remainder of the original warranty period, complete proper warranty claim documentation required.) This warranty shall not apply to any product that has been altered in any way, which has been repaired by any party other than a service representative authorized by OPW, or when failure is due to misuse, or improper installation or maintenance. OPW shall have no liability whatsoever for special, incidental or consequential damages to any party, and shall have no liability for the cost of labor, freight, excavation, cleanup, downtime, removal, reinstallation, loss of profit, or any other cost or charges.*

*For any product certified to California 2001 standards, OPW warrants that products sold by it are free from defects in material and workmanship for a period of one year from date of manufacture or one year from date of registration of installation not to exceed 15 months from date of manufacture by OPW.*

**THIS WARRANTY IS IN LIEU OF ALL OTHER WARRANTIES, EXPRESS OR IMPLIED, AND SPECIFICALLY THE WARRANTIES OF MERCHANTABILITY AND FITNESS FOR A PARTICULAR PURPOSE. THERE ARE NO WARRANTIES WHICH EXTEND BEYOND THE DESCRIPTION ON THE FACE HEREOF.**



P.O. Box 405003 \* Cincinnati, Ohio 45240-5003

1-800-422-2525 Domestically

513-870-3315 Internationally

[www.opw-fc.com](http://www.opw-fc.com)

Copyright, 2003– OPW Fueling Components Inc., Cincinnati, OH

Printed in U.S.A. p/n H11471PA – 9/03