

OPW®



A **DOVER** COMPANY

ONE COMPANY. ONE WORLD. ONE SOURCE.™

CVS₂

Central Vacuum Stage 2 Vapor Recovery

Installation and Operation Manual

**ONE COMPANY.
ONE WORLD.
ONE SOURCE.™**



ISO 9001:
2000 Registered
Company
Reference #A12174

ATTENTION:
**READ AND UNDERSTAND THIS IMPORTANT SAFETY
INFORMATION BEFORE BEGINNING WORK**

This product is to be installed and operated near the highly combustible environment of a gasoline storage tank. It is essential for your safety and the safety of others that you carefully read, understand, and follow the warnings and instructions in this manual. Failure to do so could result in danger to life and property including death, serious injury, explosion, fire or electric shock.

Failure to install this product in accordance with the instructions and warnings in this manual as well as failure to follow the requirements of the National Electric Code, federal, state, and local codes will result in voiding warranties of this product.

Only OPW trained and Certified technicians are to install and start-up the system. An OPW trained and Certified technician shall start-up the system only after careful inspection of the installation. If applicable, the start-up form shall be completed and returned to OPW Technical Support.

Installation, start-up, system maintenance and troubleshooting must be performed by qualified, certified service technicians. Certified technicians must be able to provide proof of certification at any time. Certification number is required for any start-up form to be completed or accepted by OPW as well for warranty purposes. Technicians requesting technical support that do not have the necessary proof of certification will be referred to a certified service technician.

It is your responsibility to install this product in accordance with the instructions and warnings in this manual.

OPW Customer Service (USA): 1-800-422-2525.
www.opw-fc.com

This manual is intended for individuals who are experienced in and have been trained to service and install vapor recovery systems and equipment. The installer/service provider must have knowledge and experience with all related aspects of a gasoline station construction, service, and operation.

Safety Symbols

The following safety symbols may be used throughout this manual to alert you to important precautions and safety hazards that may arise during the installation and operation of this product.

	<p>ELECTRICITY A potential shock hazard exists. High voltage is supplied to and exists in this device.</p>		<p>TURN POWER OFF Turn power off to the device and its accessories when installing and servicing the unit. Live power creates a potential spark hazard.</p>
	<p>EXPLOSIVE Gasoline and its vapor are extremely explosive if ignited.</p>		<p>NO POWER TOOLS Sparks from electric power tools can ignite gasoline and its vapors.</p>
	<p>FLAMMABLE Gasoline and its vapors are extremely flammable.</p>		<p>NO PEOPLE IN THE AREA Unauthorized people in the work area during installation and service of the device create a potential for personal injury.</p>
	<p>NO SMOKING Gasoline and its vapors can be ignited by sparks and embers of burning cigarettes.</p>		<p>READ ALL RELATED MANUALS Read, understand and follow all instructions, warnings and requirements before you begin work.</p>
	<p>NO OPEN FLAMES Open flames from sources like lighters, matches, etc. can ignite gasoline and its vapors.</p>		<p>USE SAFETY BARRICADES Unauthorized people or vehicles in the work area create a potential for injury and danger to property. Always isolate your work area by using safety cones, barricades, etc.</p>
	<p>PINCH RISK Stay clear. Keep hands and tools away from rotating machinery and moving parts.</p>		<p>ROTATING MACHINERY Stay clear. Keep hands and tools away from rotating machinery.</p>

1.0	System Description	1
2.0	Component Identification.....	3
2.1	Controller	3
2.2	Vapor Pump	3
2.3	Vapor Recovery Nozzle.....	3
2.4	A/L Regulator	3
2.5	Drain Check Valve	3
2.6	Tank Pressure Switch (Optional)	3
3.0	Component Location and Details.....	4
3.1	Controller Location	4
3.2	Controller Operation	5
3.3	Vapor Pump Location and Mounting	6
3.4	Hose Point.....	9
3.5	Drain Check Valve	10
3.6	Self Clearing Low Point	11
3.7	Tank Pressure Switch Location (Optional)	13
4.0	Vapor Piping.....	14
4.1	General Piping Guidelines	14
4.2	Vapor Pump Piping	14
4.3	Slope and Drainage Requirements	14
4.4	Dispenser Vapor Piping	15
4.5	Storage Tank Vapor Manifolds.....	17
4.6	Stage II Station Underground Piping.....	18
6.0	Electrical Requirements	24
6.1	Power Requirements	24
6.2	Vapor Pump Electrical Hook Ups.....	25
6.3	Input Channel Requirements.....	26
7.0	Other Requirements	28
7.1	Other Electrical Requirements	28
7.2	Storage Tank Overfill Devices	28
7.3	P/V Valve	28
7.4	Controller Communications	28
7.5	Data Commands	29
8.0	A/L Adjustments	30



WARNING: Only OPW trained and Certified technicians are to install and/or start-up the system. An OPW Certified technician shall start-up the system only after careful inspection of the installation, and completion of the start-up check list.

Do not power up the system unless a complete start-up inspection is completed by an OPW Certified technician.

1.0 System Description

The OPW CVS2 (Stage 2 Vapor Recovery System) is designed for gasoline dispensing facility to provide gasoline vapor collection and removal from the dispensing area (forecourt). Collected vapor is returned to the gasoline storage tank ullage space through a dedicated vapor pipe and vent network.

The OPW CVS2 system requires one base system for each gasoline dispensing facility, and one set of hose point components for each fueling position.

Description	OPW p/n	Qty
System, CVS2	00-40015	1
Each CVS2 System includes the following		
Assembly, Controller, CVS2	10-25015	1
Assembly, Vapor Pump, CVS2	11-12200	1
Installation Manual, CVS2	99-60015	1

Hose Point Components (one set required for each fueling point)

Description	OPW p/n	Qty
Nozzle, Vapor Recovery	12VW-xx57	1
Kit, A/L Regulator, Inverted	14-33056	1
Breakaway, Inverted	66CAS	1
Hose, Inverted co-ax, whip hose, 1 ft	72T2-0010	1
Hose, Inverted co-ax (0100 = 10 ft, 0120 = 12 ft, 0140 = 14 ft)	72T2-xxxx	1

Optional System Components (one per site)

Description	OPW p/n	Qty
Drain Check Valve (Compact)	11-10167	1
Tank Pressure Switch (PST-XP)	14-49505	1

Installer Supplied Components to Complete Installation

All components must meet national and local codes and requirements for use at a gasoline refueling facility.

Description

- If the CVS2 system is to be installed in locations with large voltage fluctuations, a power conditioner and/or an uninterruptible power supply should be installed. System or component damage caused by excessive power or voltage fluctuations will not be covered under warranty. See Section 6 for electrical requirements.
- Wiring; TFFN or THHN with 600 V insulation, gasoline and oil resistant, 75°C minimum, flame retardant, heat resistant for wet and dry locations.
- Metallic Conduit for all wiring runs between load center, CVS2 Controller, CVS2 Vapor Pump, and CVS2 PST-XP pressure switch.
- Dedicated overload circuit breaker at load center for CVS2 system.
- Explosion proof electrical junction box at CVS2 Vapor Pump.
- Explosion proof electrical seal off in conduit run for Vapor Pump.
- Explosion proof electrical seal off in conduit run for PST-XP pressure switch.
- Schedule 40 galvanized piping for all aboveground piping (internally and externally corrosion protected).
- Internally and externally corrosion protected 2" or 3" piping for all underground vapor piping.
- Tubing and vapor manifold for dispenser conversion from standard to vapor recovery.
- Hardware for mounting CVS2 Controller.
- Hardware for mounting CVS2 Vapor Pump.
- Gasoline resistant pipe thread sealant (UL Classified).
- Underground containment sump for Drain Check Valve installation (Drain Check Valve be installed in existing containment sump).
- Equipment to measure and adjust A/L (VacuChek, VacuSmart, or other approved method).

2.0 Component Identification

2.1 Controller

The Controller is the logic center of the CVS2 System. It monitors all of the liquid dispensing pumps on the site as well as activating and monitoring the performance of the CVS2 Vapor Pump when any liquid dispensing pump is active. If any fault in Vapor Pump operation is detected, the CVS2 Controller will sound an alarm.

The Controller incorporates the following features:

- Indicator lamps (Power, Vapor Pump On, Alarm)
- Audible alarm indicator
- Reset / Silence / Self Test button
- Liquid dispensing pumps inputs: 24 (suctions or turbines)
- Port for serial communications (DB9)
- Operating temperature range: 32° F to 104°F (0°C to 40°C)

2.2 Vapor Pump

The CVS2 Vapor Pump is a centralized pump allowing for a single Vapor Pump to control vapor emissions for up to 16 fueling points (8 dispensers). The Vapor Pump is a non-contact regenerative blower, specifically designed for gasoline vapor recovery, that allows for many year of trouble-free and maintenance-free operation. For greater than 16 fueling points, a second Vapor Pump can be installed.

2.3 Vapor Recovery Nozzle

OPW 12VWxx-57 bootless nozzles allow for ease of use and high flow rates when filling all types of vehicles.

2.4 A/L Regulator

Each hose point has an A/L Regulator which controls the volume of vapor collected by the CVS2 Vapor Pump as well as functioning as the adapter that converts a non-vapor recovery dispenser to allow for vapor recovery handing hardware to be used. Each A/L Regulator is adjusted at system start-up to ensure proper vapor collection for each hose point.

2.5 Drain Check Valve

The Drain Check Valve allows liquid that has condensed in the vapor piping to drain back to the storage tank. If site specific configurations allow for manual draining of condensed vapors or self clearing low points, then the Drain Check Valve is not needed. See Typical Site Drawings.

2.6 Tank Pressure Switch (Optional)

The Tank Pressure Switch monitors the UST pressure. If installed, the Tank Pressure Switch will send a signal to the CVS2 Controller when the storage tank pressure exceed +2.5 inwc.

3.0 Component Location and Details

3.1 Controller Location



WARNING: Installation of this product must comply with the National Electric Code, federal, state and local codes, as well as other applicable safety codes.



WARNING



The Controller must be installed in a non-Hazardous location. Explosion or fire resulting in serious injury or death, or property loss or damage could occur if the User Interface is installed in a Hazardous location.



Do not install the Controller in or near any combustible or explosive atmosphere.

1. The Controller must be installed indoors and protected from the weather.
2. The Controller must be installed so station personnel can hear the audible alarm and have clear access to the Controller.
3. All conduit connections must be made through the factory provided knockouts in the bottom of the enclosure. All unused knockouts must be plugged.
4. There are no end user serviceable parts within the User Interface enclosure.
5. The Controller enclosure is 10" high, 10" wide, and 4" deep.
6. Securely mount the CVS2 Controller enclosure to a wall.

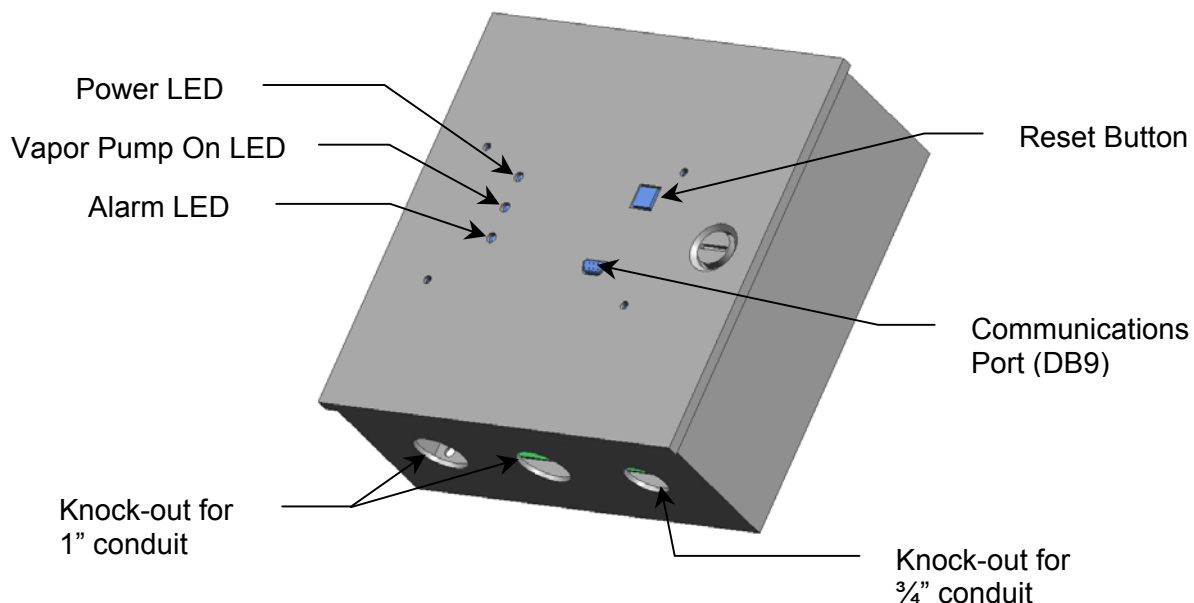

3.2 Controller Operation

The Controller is the logic center of the CVS2 System. It monitors all of the liquid dispensing pumps on the site as well as controlling and monitoring the performance of the CVS2 Vapor Pump.

1. The CVS2 Controller will alarm if:
 - a. the Vapor Pump motor current is not sensed within 10 seconds of the Vapor Pump relay closing.
 - b. the Vapor Pump motor current is lost for more than 10 seconds while it is running and any liquid delivery pump motor current is sensed.
 - c. the Vapor Pump experiences a locked rotor condition for more than 5 seconds (excessive current draw).

2. To Silence/Reset an Alarm:
 - a. In the event of an fault condition, the audible buzzer will sound, and the "Alarm" LED will flash.
 - b. To silence the audible alarm, press the RESET button once. This will initiate a pump test and silence the buzzer. The "Pump On" LED will flash for up to 10 seconds during the pump test (the Vapor Pump relay will close to try and start the Vapor Pump).
 - c. If the Vapor Pump successfully starts (i.e. fault conditions no longer exists), the "Alarm" LED will stop flashing and the alarm is automatically cleared.
 - d. If the Vapor Pump does not start or is over current, the "Alarm" LED will continue to flash (without the buzzer). The "Alarm" LED will flash until either 1) the Vapor Pump starts after a RESET button press, or 2) the power to the Controller is cycled.
 - e. Note: when in alarm, there is no limit to the number of times the RESET button can be pressed to initiate a pump test. But, as long as the fault condition exists, the alarm will continue until the fault is remedied.

3.3 Vapor Pump Location and Mounting



WARNING: Installation of this product must comply with the National Electric Code, federal, state and local codes, as well as other applicable safety codes.



WARNING

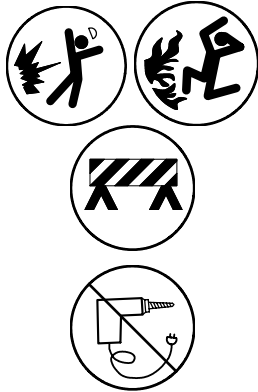

The Vapor Pump may be installed in or near locations where highly flammable and explosive vapors and liquids may be present. Risk of fire, explosion, serious injury or death.

You are working in an area where vehicle traffic may occur. Always block off the work area during installation and service to protect yourself and others.

Do not use power tools that can generate sparks if there is a risk of flammable or explosive vapors or liquids being present.

1. Locate the Vapor Pump so it is protected from vandalism, vehicle damage, or water flooding. It may be located on the ground, a roof of a building, or a canopy.
2. Keeping the Vapor Pump cool will prolong its life; this can be achieved by installing the Vapor Pump in the shade in hot locations. Do not install the Vapor Pump in an enclosure with limited or no ventilation.
3. A hazardous location is created by the Vapor Pump as per NFPA 30A. The hazardous location is defined as Class 1, Group D, Division 2. This area extends to 18 inches in all directions of the equipment extending to grade level, and up to 18 inches above grade level within 10 feet horizontally. Verify distances with local authorities. Install an electrical seal-off in the conduit to the Vapor Pump motor per local regulations.
4. The hazardous location typically does not extend beyond a solid floor, wall, roof, or other partition that has no communicating openings.
5. If the Vapor Pump is located where vehicle or pedestrian traffic has access, measures must be taken to protect the Vapor Pump and exposed piping from damage or vandalism. Installation of vehicle bumper posts or fenced enclosures may be necessary. Use POMECS/OPW pipe guards (POMECS SPG, 6PGU, or 6PGR series guards).
6. The Vapor Pump must be permanently anchored to concrete or another solid base. Use minimum 5/16" hardware.
7. Only mount the Vapor Pump so the inlet and outlet piping is horizontal.
8. **Do not** install piping which can stress the pump face. This may result in a locked vane.

Vapor Pump Foot Print and Mounting

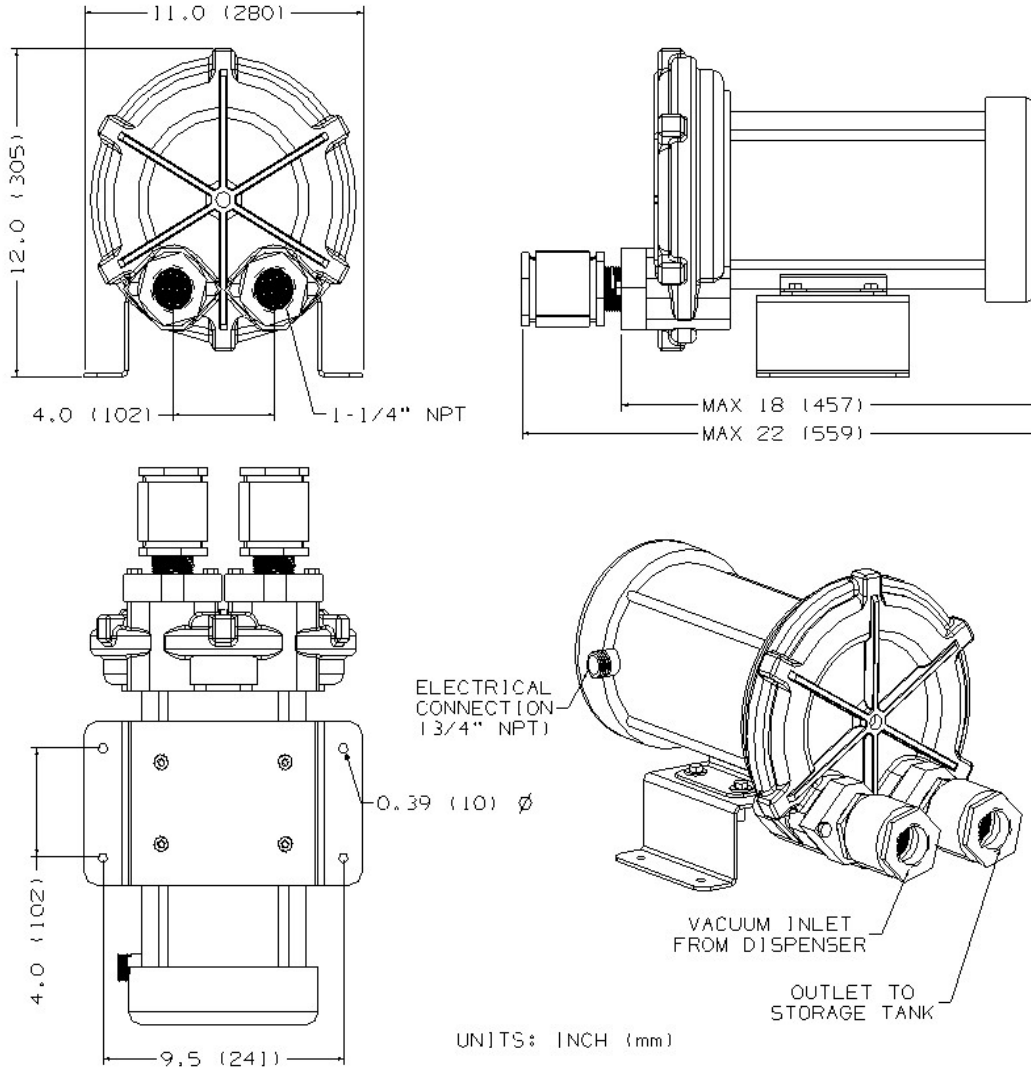

Classified/Hazardous Areas

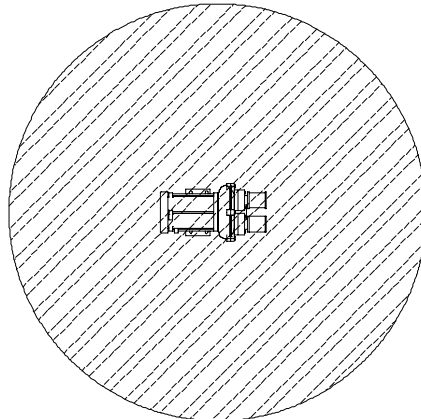

TOP VIEW

NOTE:

ALL DEVICES INSTALLED WITHIN THESE HAZARDOUS ZONES MUST COMPLY WITH ALL APPLICABLE CODES FOR SPECIFIC ZONE.

OBTAIN APPROVAL FROM THE LOCAL AUTHORITY HAVING JURISDICTION.

ATTENTION MUST BE PAID TO HAZARDOUS ZONES CREATED BY OTHER EQUIPMENT AT THE FACILITY.

SOURCE: NFPA30/30A/70

CLASS I, GROUP D, DIVISION 2

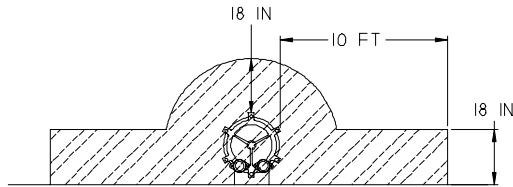

SIDE VIEW

IM-VR 153

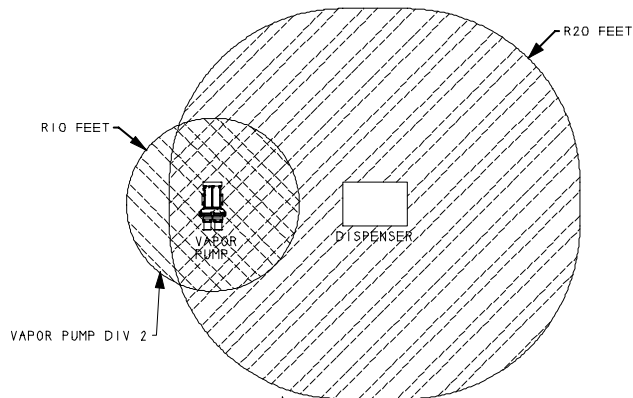
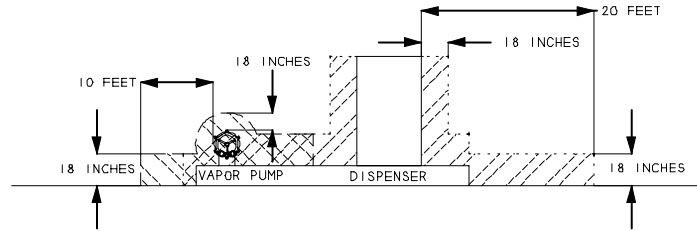

SOURCES: NFPA30/30A/70

DISPENSER DIV 2

IM-VR 153

3.4 Hose Point

1. Each hose point shall have the following:
 - a. A/L Regulator (Inverted)
 - b. Inverted coaxial whip hose (typically 1 foot)
 - c. Breakaway (OPW 66CAS)
 - d. Inverted coaxial hose
 - e. Nozzle (OPW 12VW-xx57)
2. The A/L Regulator also serves as a dispenser adapter to convert non-vapor recovery dispensers to accommodate the CVS2 Stage 2 vapor recovery system.
 - a. The liquid inlet port is $\frac{3}{4}$ " NPT.
 - b. The vapor port is $\frac{1}{4}$ " NPT.
 - c. Avoid low points in the vapor hose between the A/L regulator and the dispenser manifold.

Typical Hose Point Installation

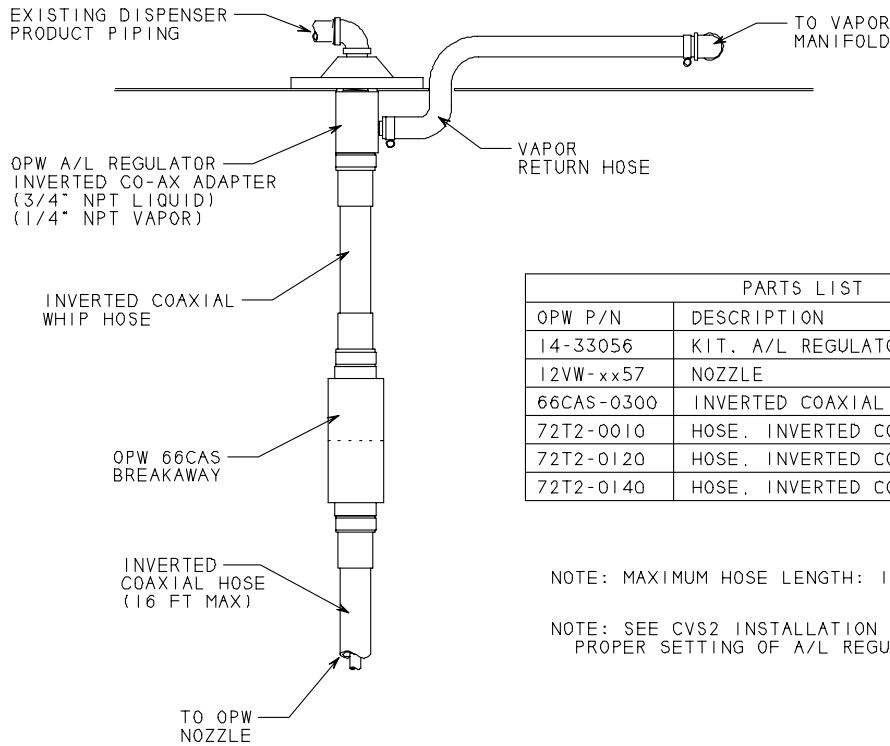

PARTS LIST	
OPW P/N	DESCRIPTION
14-33056	KIT, A/L REGULATOR, INVERTED ADAPTER
12VW-xx57	NOZZLE
66CAS-0300	INVERTED COAXIAL BREAKAWAY
72T2-0010	HOSE, INVERTED COAX, 1 FT (WHIP)
72T2-0120	HOSE, INVERTED COAX, 12 FT
72T2-0140	HOSE, INVERTED COAX, 14 FT

NOTE: MAXIMUM HOSE LENGTH: 16 FT

NOTE: SEE CVS2 INSTALLATION MANUAL FOR PROPER SETTING OF A/L REGULATOR

IM-VR168

3.5 Drain Check Valve

1. The Drain Check Valve allows vapor condensation in the vapor collection piping to drain to the storage tank.
2. The Drain Check Valve is installed at the low point in the vapor collection (vacuum) piping.

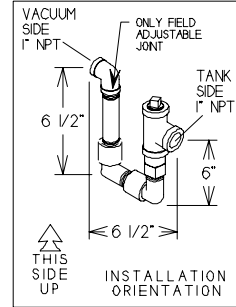
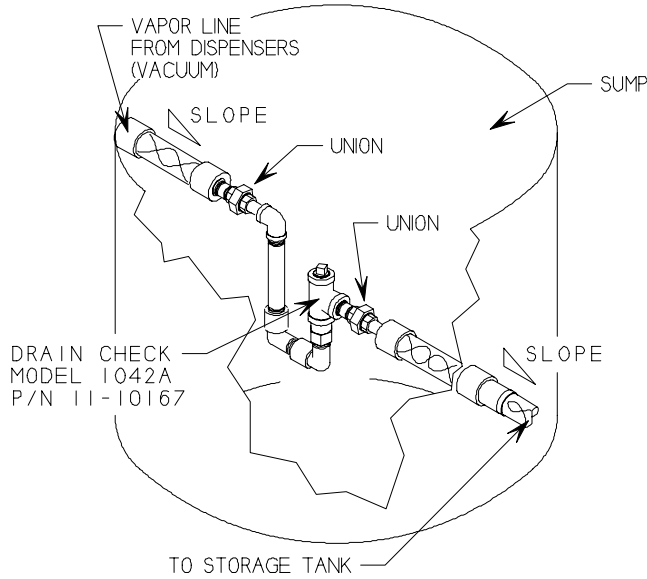

NOTE:

UNIONS MUST BE INSTALLED ON BOTH SIDE OF THE DRAIN CHECK ASSEMBLY.

SLOPE OF VACUUM SIDE PIPING MUST BE TO THE DRAIN CHECK.

SLOPE OF THE TANK SIDE PIPING MUST BE TO THE STORAGE TANK.

IM-VR042

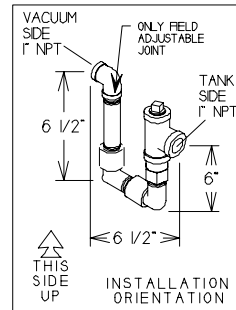
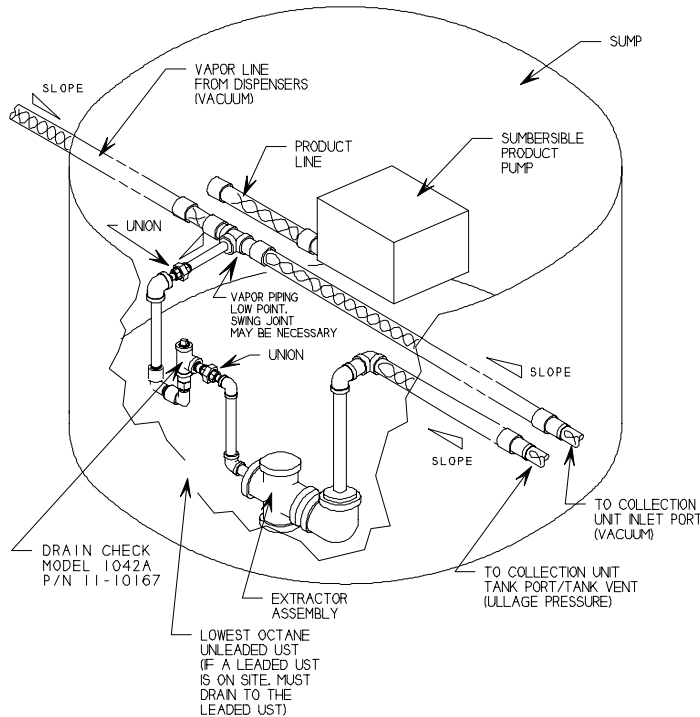

NOTE:

UNIONS MUST BE INSTALLED ON BOTH SIDE OF THE DRAIN CHECK ASSEMBLY.

SLOPE OF VACUUM SIDE PIPING MUST BE TO THE DRAIN CHECK.

SLOPE OF THE TANK SIDE PIPING MUST BE TO THE LOWEST OCTANE UST.

IM-VR043

3.6 Self Clearing Low Point

1. As an alternate to the Drain Check Valve a self clearing low point can be installed in the vapor piping system.
2. The low point can be between the dispensers and the Vapor Pump, or as a separate leg of the vapor piping.
3. Use the submersible turbine suction port to continuously clear any condensation that is collected.
4. If suction pumps in dispensers have an available suction port, this configuration could be used within each dispenser. Verify application with suction pump manufacturer.

Typical Self Clearing Low Point (Inline)

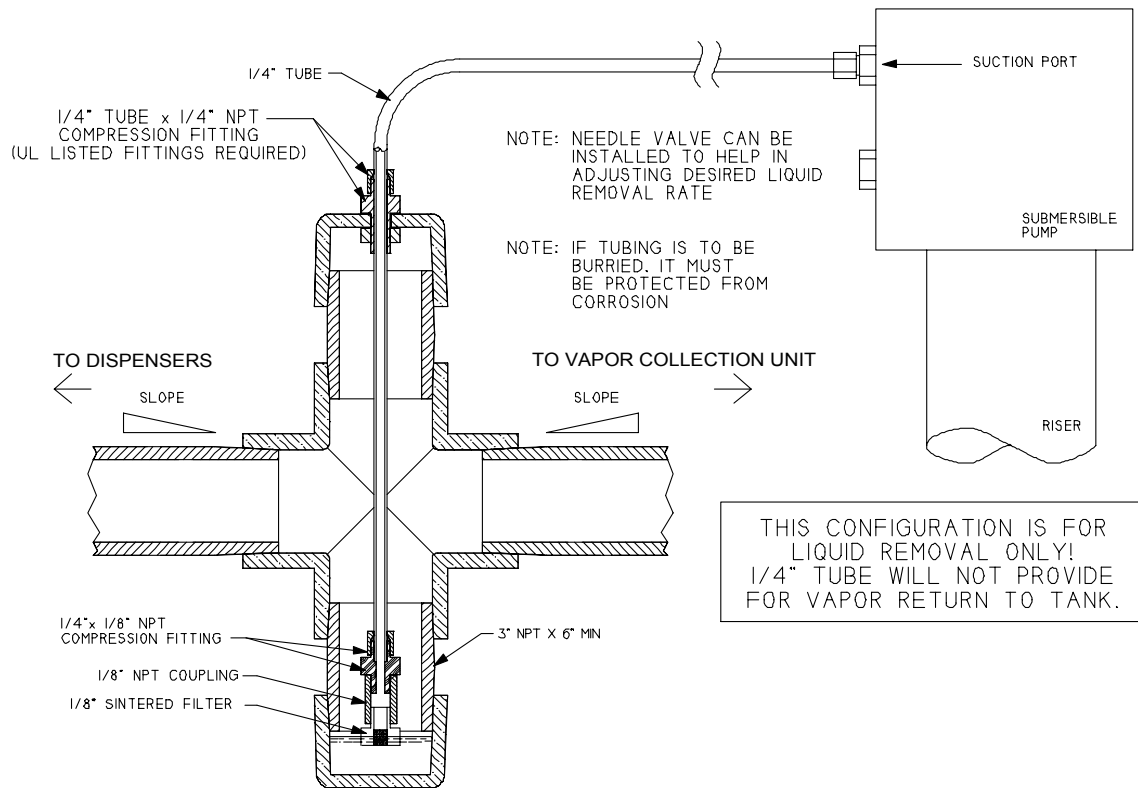

IM-VR031

Typical Self Clearing Low Point (Dedicated Line)

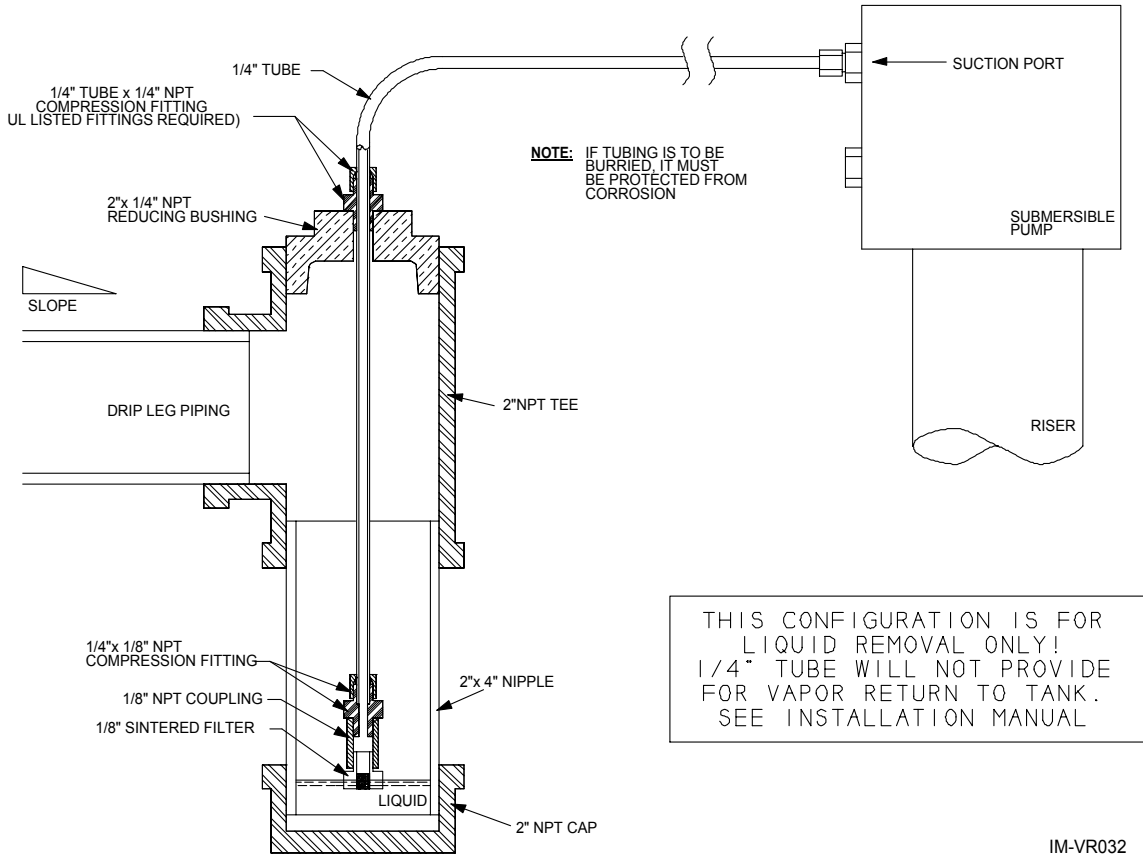

IM-VR032



3.7 Tank Pressure Switch Location (Optional)

1. Locate Tank Pressure Switch on or near the storage tank vent piping.
2. Use OPW Mounting Kit to mount the Tank Pressure Switch directly to a vent pipe.
3. Connect the “High” port on the Tank Pressure Switch to the vent. Use ¼” copper tubing with compression or flare fittings.
4. Always follow the requirements of the local and national authorities when working in Hazardous Locations where explosive vapors will be present. Install a conduit seal-off on electrical conduit as required by local regulations.

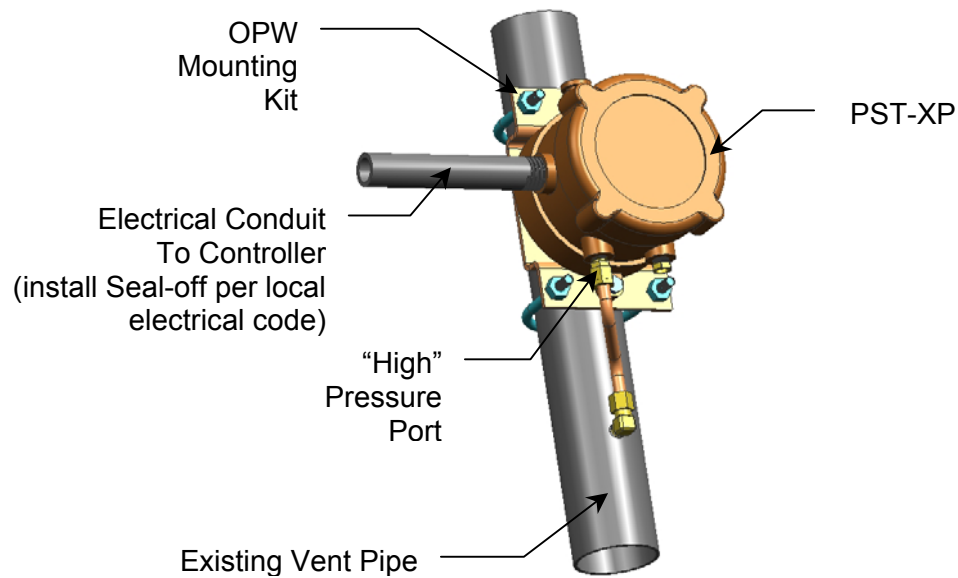
Typical PST-XP Installation



4.0 Vapor Piping

 WARNING	
	<p>The components of the CVS2 systems are to be installed near locations where highly flammable and explosive vapors and liquids may be present. Risk of Fire, Property Damage, Serious Injury and Death.</p> <p>If working in an area where vehicle traffic may occur. Always block off the work area during installation and service to protect yourself and others.</p> <p>Do not use power tools that can generate sparks if there is a risk of flammable or explosive vapors or liquids being present. Open piping to the gasoline storage tank will be emitting dangerous, flammable and potentially explosive vapors. Do not smoke or have open flames in areas near open piping.</p>

4.1 General Piping Guidelines

1. All aboveground piping must be schedule 40 galvanized; only use pipe that is internally and externally corrosion protected. Underground piping (typically fiberglass) shall meet requirements of the local authority.
2. All underground piping must be internally and externally corrosion protected and meet requirements of the local authority.
3. Pipe threads shall be clean cut and coated with UL Classified thread sealant.
4. The vapor piping is to be 2 inch inner diameter or larger except for the stubs into the dispensers, which are typically $\frac{3}{4}$ inch or 1 inch diameter, and $\frac{1}{2}$ or $\frac{3}{4}$ inch tubing inside the dispenser.
5. Special care must be taken to avoid low points or traps in the vapor piping and tubing while maintaining a continuous slope of minimum $\frac{1}{8}$ inch per foot.

4.2 Vapor Pump Piping

1. The Vapor Pump is supplied with inlet and outlet flame arrestors; do not remove them.
2. All piping connecting to the Vapor Pump flame arrestors must be minimum 2 inch.
3. Piping must slope away from the CVS2 Vapor Pump.
4. Do not install piping which can stress the pump face. This may result in a locked vane.

4.3 Slope and Drainage Requirements

1. All piping shall be sloped so that condensate drains toward the storage tanks. The minimum slope is $\frac{1}{8}$ inch per foot ($\frac{1}{4}$ inch per foot is recommended).

2. If slope and natural drainage cannot be achieved, liquid dropout points must be installed and manually emptied regularly or connected to an automatic pump to continuously clear any accumulated liquid.
3. If a manually drained low point is used, it is critical that it be drained regularly. Without proper draining, condensation will accumulate and potentially block the vapor recovery piping and compromise the vapor collection efficiency.

NOTE: The minimum slope requirements must be met in order to ensure adequate drainage of any liquid in the vapor piping. Liquid blockage in the lines will degrade system performance.

4.4 Dispenser Vapor Piping

1. Vapor tubing within the dispenser must be minimum 1/2 inch inner diameter.
2. All tubing must drain to a low point that is either automatically or manually drained.
3. If a manually drained low point is used, it is critical that it be drained regularly. Without proper draining, condensation will accumulate and potentially block the vapor recovery piping and compromise the vapor collection efficiency.

Typical Dispenser with Underground Vapor Piping

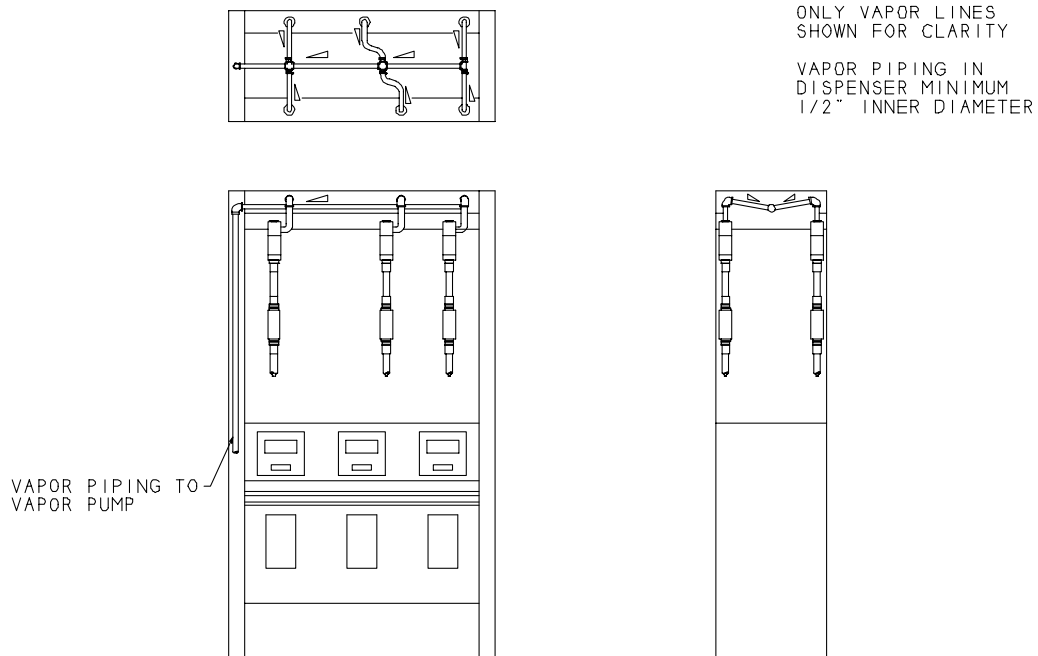

IM-VR151

Typical Dispenser with Overhead Vapor Piping

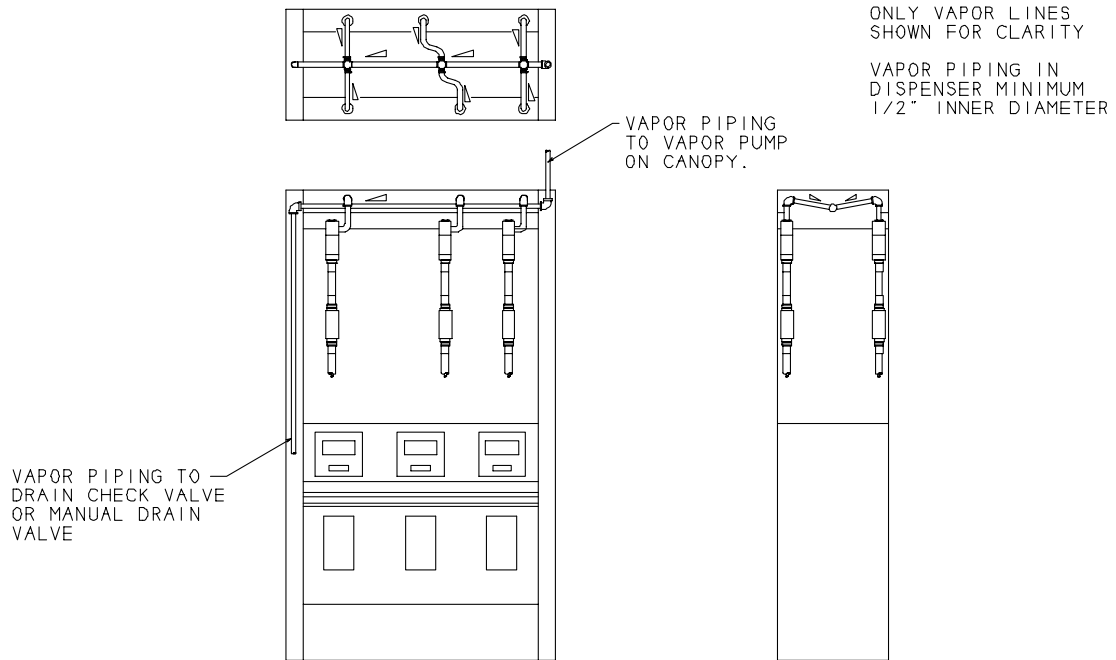

IM-VR150

4.5 Storage Tank Vapor Manifolds

1. Storage tanks must be vapor manifold (above and/or below grade). Follow requirements of the local authority.
2. Above ground manifold should be minimum 12 feet above adjacent grade. Follow requirements of the local authority.
3. Tank vent openings must be greater than 12 feet above adjacent grade and have Approved Pressure/Vacuum valves.
4. All above ground vapor piping must be schedule 40 galvanized steel, and painted to minimize solar heat gain.
5. A hazardous location is created by the vents as per NFPA 30A (verify hazardous location with the local authority having jurisdiction).
 - a. Class 1, Group D, Division 1 within 3 feet in all directions of the vent opening.
 - b. Class 1, Group D, Division 2 between 3 and 5 feet in all directions of the vent opening.
 - c. The classified area shall not extend beyond a solid floor, wall, roof, or other partition that has no communicating openings.

Typical Vent Manifold

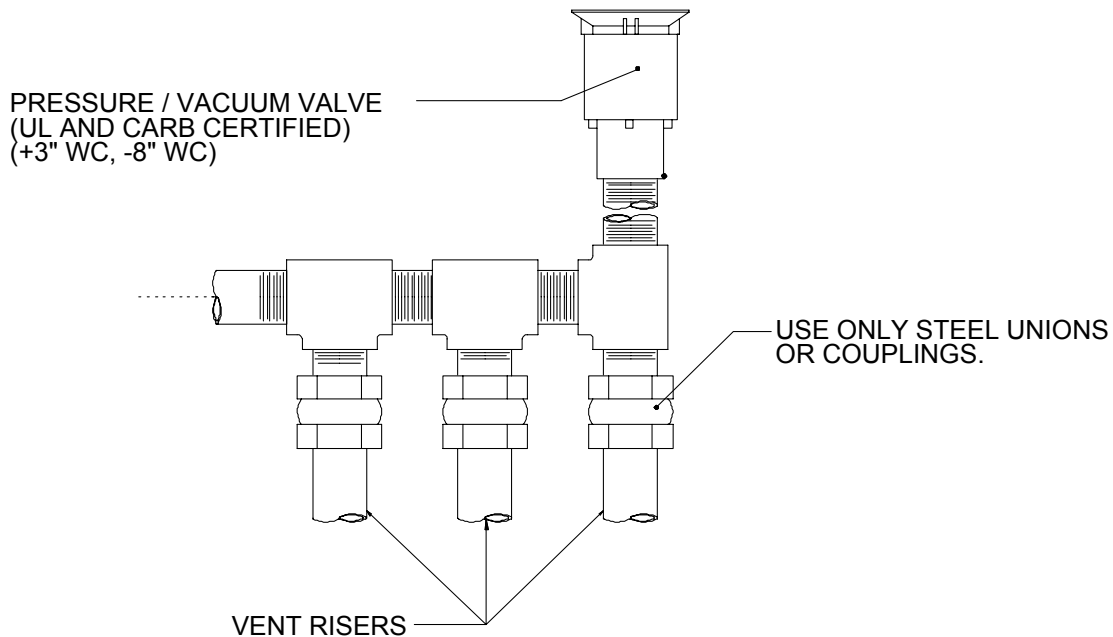

IM-VR009

4.6 Stage II Station Underground Piping

1. All underground vapor piping must be a minimum of 2 inch inner diameter. Always check with local authorities for applicable requirements; larger pipe size may be required.
2. All vapor piping must have slope for drainage to the underground storage tanks.
3. Minimum slope is $\frac{1}{8}$ inch drop per foot run. Recommended wherever possible $\frac{1}{4}$ inch drop per foot run.
4. Always follow the requirements of the local authority.

Typical Vapor Piping Layout

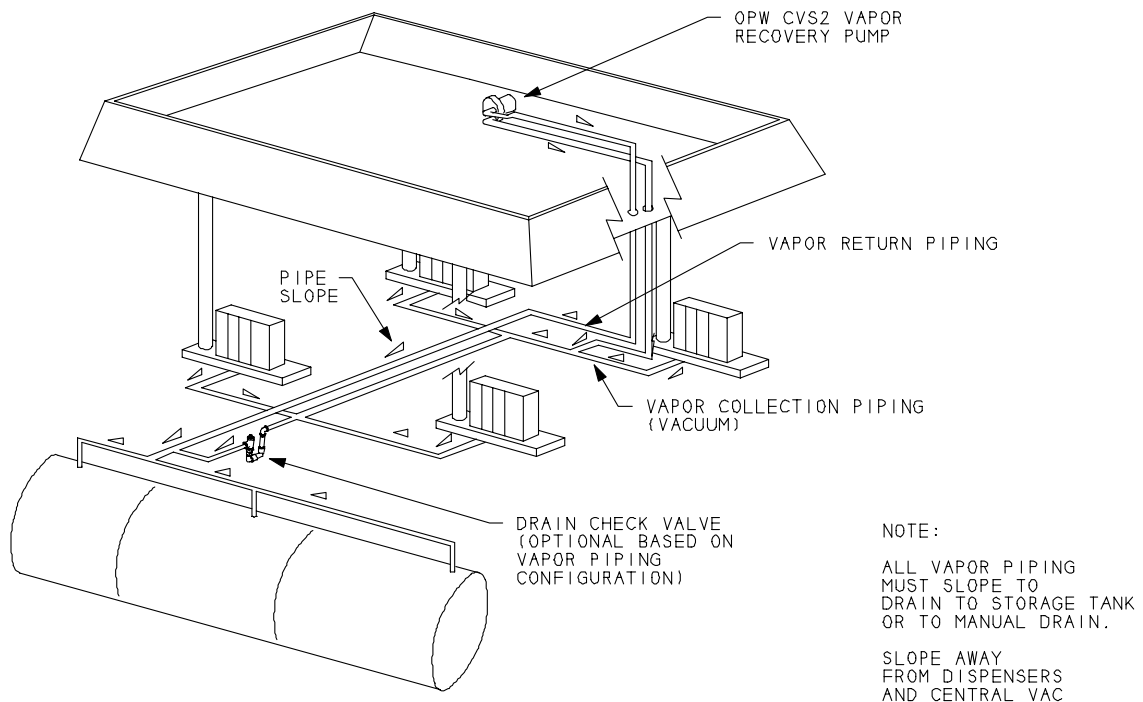

▲
PIPING SLOPE:
MINIMUM 1/8 INCH DROP/FOOT RUN
RECOMMEND 1/4 INCH DROP/FOOT RUN

IM-VR123

Notes:

- Always follow requirements of component and system manufacturers, local, state and national authorities for installation and operation of all equipment.

Typical Vapor Piping Layout

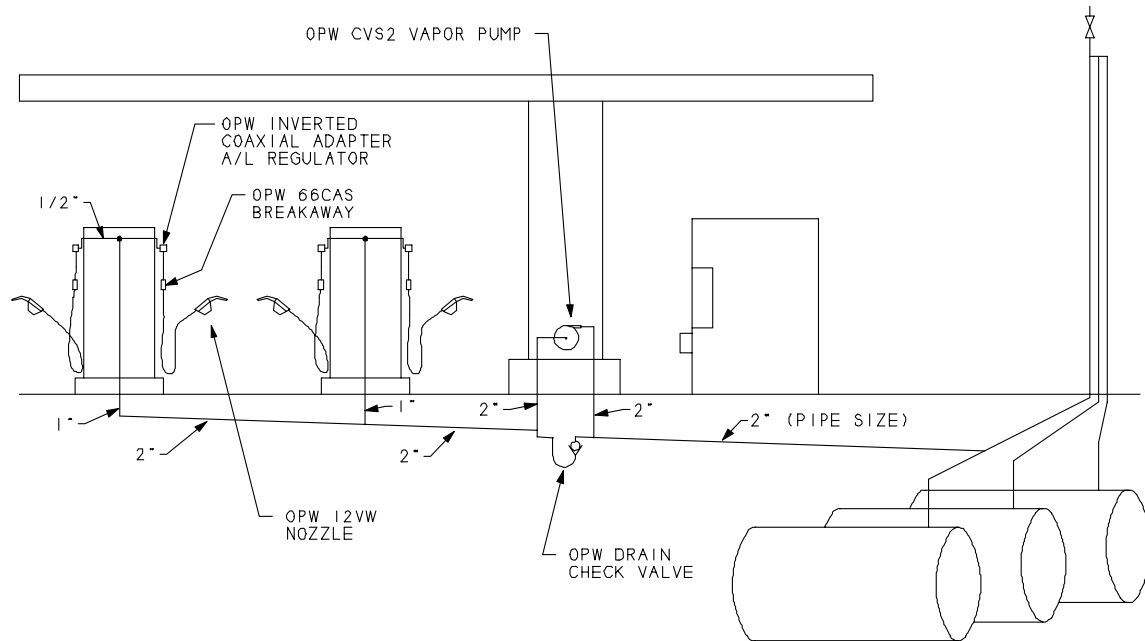

ONLY VAPOR LINES
SHOWN FOR CLARITY

TANKS SHOWN UNDER
CANOPY FOR DRAWING
COMPACTNESS ONLY!

IM-VR127

Notes:

- Always follow requirements of component and system manufacturers, local, state and national authorities for installation and operation of all equipment.

Typical Vapor Piping Layout

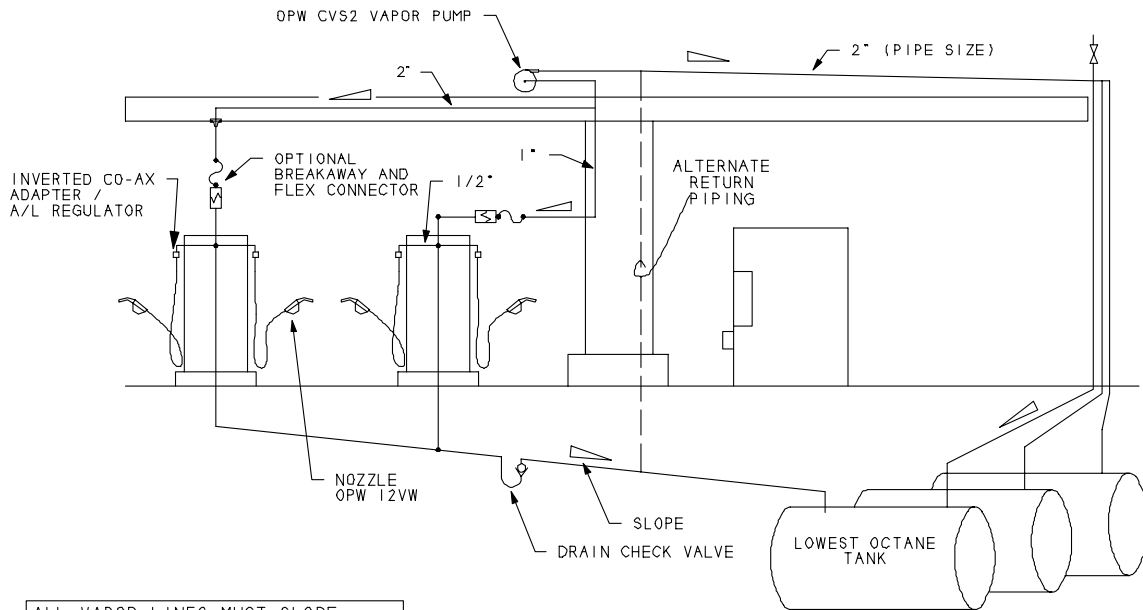

ALL VAPOR LINES MUST SLOPE TOWARDS THE UNDERGROUND STORAGE TANKS.

ALL VAPOR LINES MUST SLOPE AWAY FROM PROCESSOR. MIN. 1/8 INCH PER FOOT.

ONLY VAPOR LINES SHOWN FOR CLARITY

TANKS SHOWN UNDER CANOPY FOR DRAWING COMPACTNESS ONLY!

1M-VR125

Note:

- Always follow requirements of component and system manufacturers, local, state and national authorities for installation and operation of all equipment.

Typical Vapor Piping Layout

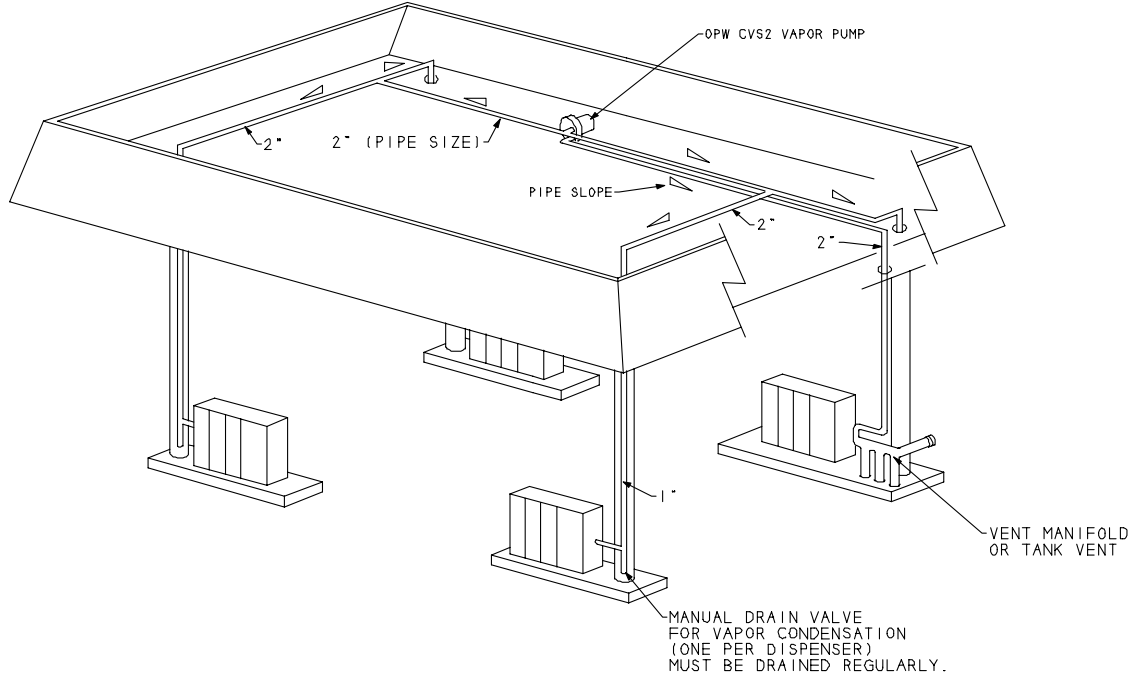

NOTE:
OVERHEAD VAPOR PIPING WITH
MANUAL CONDENSATE DRAIN VALVES
(NO DRAIN CHECK VALVE)

IM-VR126

Note:

- If a manually drained low point is used, it is critical that it be drained regularly. Without proper draining, condensation will accumulate and potentially block the vapor recovery piping and compromise the vapor collection efficiency.
- Always follow requirements of component and system manufacturers, local, state and national authorities for installation and operation of all equipment.

Typical Vapor Piping Layout

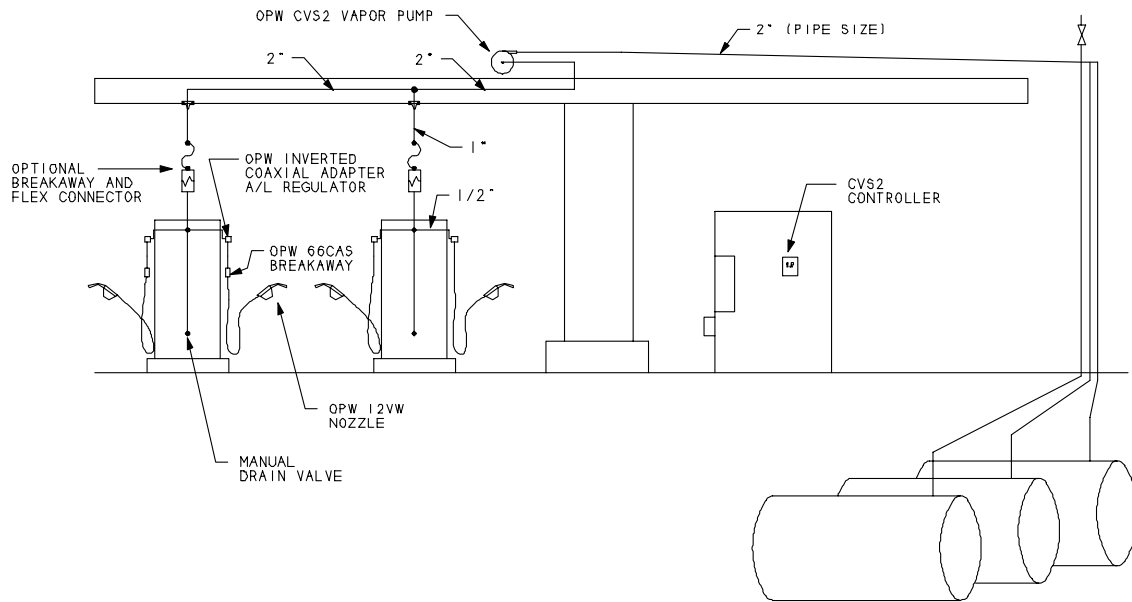

ONLY VAPOR LINES
SHOWN FOR CLARITY

TANKS SHOWN UNDER
CANOPY FOR DRAWING
COMPACTNESS ONLY!

IM-VR169

Note:

- If a manually drained low point is used, it is critical that it be drained regularly. Without proper draining, condensation will accumulate and potentially block the vapor recovery piping and compromise the vapor collection efficiency.
- Always follow requirements of component and system manufacturers, local, state and national authorities for installation and operation of all equipment.

Typical Vapor Piping Layout

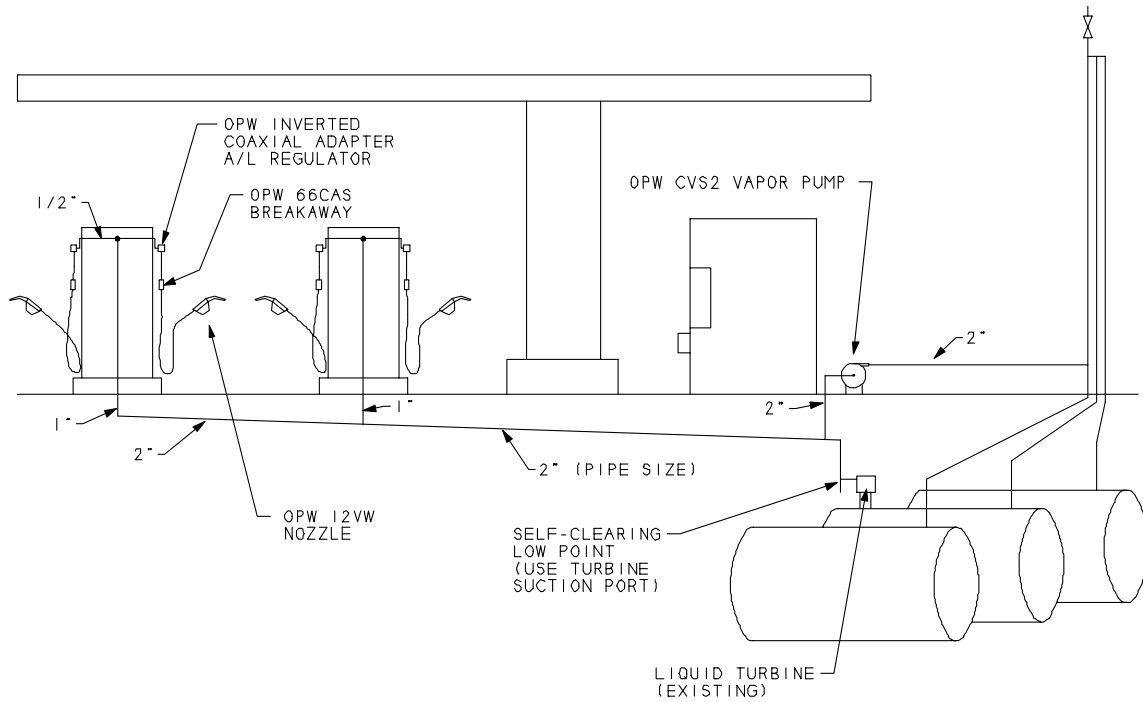

ONLY VAPOR LINES
SHOWN FOR CLARITY



TANKS SHOWN UNDER
CANOPY FOR DRAWING
COMPACTNESS ONLY!

IM-VR154

Notes:

- See Section 4.5 (Drawings IM-VR031 and IM-VR032) for details of the Self-Clearing Low Point.
- Always follow requirements of component and system manufacturers, local, state and national authorities for installation and operation of all equipment.

6.0 Electrical Requirements

 WARNING	
	<p>This system uses lethal voltages and operates in areas where flammable vapors and liquids may be present.</p> <p>Serious injury or death from electrical shock, fire, or explosion may result if the power is on during installation.</p> <p>Turn power off, lockout and tag power to the unit while installing the system.</p> <p>Read and understand all instructions in this manual and all applicable requirements of the National Electric Code, federal, state and local codes, as well as other applicable safety codes.</p>

6.1 Power Requirements

1. System: 115/230 VAC at 60 Hz, 110/220 VAC at 50Hz, single phase, $\frac{3}{4}$ amp plus $\frac{1}{2}$ hp.
 - a. Controller: 115/230 VAC at 60 Hz; 110/220 VAC at 50 Hz; Single Phase; $\frac{3}{4}$ amp.
 - b. Vapor Pump/Motor: 115/230 VAC at 60 Hz; 110/220 VAC at 50 Hz; Single Phase; $\frac{1}{2}$ hp.
 - c. The Vapor Pump requires different wiring connections at the pump motor for either 110/115 or 220/230; see wiring diagram at the end of this manual or the label on motor for connection details. The Controller can accept either 110/115 or 220/230 into the L1 and L2 terminals without any required wiring changes.
2. Power conditioning and/or an uninterruptible power supply are required if the system is installed where excessive voltage fluctuations exist.
 - a. For 230 volt installations, the voltage must be controlled to 207-253 volts.
 - b. For 115 volt installations, the voltage must be controlled to 104-127 volts.
 - c. Voltages outside these ranges will likely result in vapor pump motor and Controller damage.
3. Controller Pump Input Channels
DO NOT exceed 15 amp RMS from external pump/motor into each input channel.
4. A readily accessible two pole disconnect device must be incorporated in the installation wiring for the motor.
5. An electrical service disconnect (breaker) of minimum 20 amp / 240V should be used.
6. This product shall be installed in accordance with the National Electrical Code (NFPA 70) and the Automotive and Marine Service Station Code (NFPA 30A), and all applicable local and national regulations.

7. The CVS2 main power should be controlled by the facility's main Emergency Shut-Off system; follow the requirements of the local authority.

6.2 Vapor Pump Electrical Requirements

1. Wiring between the Controller and the Vapor Pump shall be as follows.
 - a. All wiring to be TFFN or THHN with 600 V insulation, gasoline and oil resistant, 75°C minimum, flame retardant, heat resistant for damp and dry locations.
 - b. A ground wire shall run from the Vapor Pump to the Controller and continue to the load center ground. The ground wire must be minimum 12 AWG.
 - c. Wiring for power to the Vapor Pump shall be minimum 12 AWG; sizing must comply with NEC requirements for motor load and wiring distance. Larger gage wire may be necessary based on conductor length and voltage supplied by load center.
 - i. The following table should be used as a guide to help in correctly sizing motor conductors based on length. Always follow NEC and the requirements of the local authorities.
 - ii. The following table is based on using a conductor ampacity rating of 140% of the motor nameplate rating. Motor nameplate: 7.5 A at 115 VAC; 140% of motor nameplate: 10.5A.
 - iii. NEC recommends a maximum conductor voltage drop of 3%, but notes that with a conductor voltage drop of 5%, most devices should operate with acceptable efficiency. It should be noted that with a conductor voltage drop of 5%, motor starting capabilities are reduced, and difficult starting may occur especially if other loads on the same circuit are active. Lower conductor voltage drop is always better for motor starting and motor operating efficiency; so whenever possible use the 3% conductor voltage drop.
 - iv. Running voltage at the motor must never drop below 5% of the name plate voltage. Motor operation may become significantly affected.

Maximum conductor length is the total length of the conductor from the load center to the Controller to the Vapor Pump/motor.

Maximum Conductor Length (feet)				
Voltage	115	115	230	230
% Voltage Drop	3%	5%	3%	5%
AWG				
Feet (maximum)				
12	83	139	334	557
10	133	221	531	884
8	211	352	845	1408

Note: This table is only a guide. Always refer to the requirements of the National Electric Code and of the local authorities.

6.3 Input Channel Requirements

The Controller monitors all of the liquid dispensing pumps on the site as well as controlling and monitoring the performance of the CVS2 Vapor Pump.

1. Input Channels
 - a. There are 24 input channels to monitor the liquid dispensing pumps.
 - b. Input current to trigger Vapor Pump: Adjustable (see below).
 - c. Maximum input current: 15 amps RMS (CAUTION: any current greater than 15 amps RMS can damage the current sensing components)

2. Input Channel Current Trigger Threshold Adjustment
 - a. On the Controller PCB (located on the inside of the enclosure door) there is a 4 position DIP switch. This switch allows the input channels trigger current to be selectable based the current rating of the liquid pumps being monitored.
 - b. The input channel trigger threshold can be adjusted between 0.5 and 7.5 amps RMS.
 - c. The trigger current set point should typically be at least 0.5 amps to 1.0 amps lower than the normal running current of the liquid pump being monitored.
 - d. If the threshold is set too high, the Vapor Pump will start with the liquid pump, but turn off within a few seconds (the Controller is only sensing the starting inrush current of the liquid pump), or will not start at all. To resolve, lower the trigger current.
 - e. If the threshold is set too close to the normal running current of the liquid pump, the Vapor Pump will be cycling on and off even though the liquid pump remains on. To resolve, lower the trigger current.
 - f. If the Vapor Pump is always on, verify if there is current from other sources on the same circuit (i.e. light, electronics...). To resolve, set the trigger higher than the steady background current, but lower than the liquid pump motor running current.

Input Channel Current Trigger Threshold Adjustment

SETTING	CONFIGURATION	SETTING	CONFIGURATION																																								
0.5 A	<table style="border-collapse: collapse;"> <tr><td>0.5A</td><td><input type="checkbox"/></td><td>OFF</td><td><input type="checkbox"/></td><td>ON</td></tr> <tr><td>1.0A</td><td><input type="checkbox"/></td><td><input type="checkbox"/></td><td><input type="checkbox"/></td><td><input type="checkbox"/></td></tr> <tr><td>2.0A</td><td><input type="checkbox"/></td><td><input type="checkbox"/></td><td><input type="checkbox"/></td><td><input type="checkbox"/></td></tr> <tr><td>4.0A</td><td><input type="checkbox"/></td><td><input type="checkbox"/></td><td><input type="checkbox"/></td><td><input type="checkbox"/></td></tr> </table>	0.5A	<input type="checkbox"/>	OFF	<input type="checkbox"/>	ON	1.0A	<input type="checkbox"/>	<input type="checkbox"/>	<input type="checkbox"/>	<input type="checkbox"/>	2.0A	<input type="checkbox"/>	<input type="checkbox"/>	<input type="checkbox"/>	<input type="checkbox"/>	4.0A	<input type="checkbox"/>	<input type="checkbox"/>	<input type="checkbox"/>	<input type="checkbox"/>	4.5 A	<table style="border-collapse: collapse;"> <tr><td>0.5A</td><td><input type="checkbox"/></td><td>OFF</td><td><input type="checkbox"/></td><td>ON</td></tr> <tr><td>1.0A</td><td><input type="checkbox"/></td><td><input type="checkbox"/></td><td><input type="checkbox"/></td><td><input type="checkbox"/></td></tr> <tr><td>2.0A</td><td><input type="checkbox"/></td><td><input type="checkbox"/></td><td><input type="checkbox"/></td><td><input type="checkbox"/></td></tr> <tr><td>4.0A</td><td><input type="checkbox"/></td><td><input type="checkbox"/></td><td><input type="checkbox"/></td><td><input type="checkbox"/></td></tr> </table>	0.5A	<input type="checkbox"/>	OFF	<input type="checkbox"/>	ON	1.0A	<input type="checkbox"/>	<input type="checkbox"/>	<input type="checkbox"/>	<input type="checkbox"/>	2.0A	<input type="checkbox"/>	<input type="checkbox"/>	<input type="checkbox"/>	<input type="checkbox"/>	4.0A	<input type="checkbox"/>	<input type="checkbox"/>	<input type="checkbox"/>	<input type="checkbox"/>
0.5A	<input type="checkbox"/>	OFF	<input type="checkbox"/>	ON																																							
1.0A	<input type="checkbox"/>	<input type="checkbox"/>	<input type="checkbox"/>	<input type="checkbox"/>																																							
2.0A	<input type="checkbox"/>	<input type="checkbox"/>	<input type="checkbox"/>	<input type="checkbox"/>																																							
4.0A	<input type="checkbox"/>	<input type="checkbox"/>	<input type="checkbox"/>	<input type="checkbox"/>																																							
0.5A	<input type="checkbox"/>	OFF	<input type="checkbox"/>	ON																																							
1.0A	<input type="checkbox"/>	<input type="checkbox"/>	<input type="checkbox"/>	<input type="checkbox"/>																																							
2.0A	<input type="checkbox"/>	<input type="checkbox"/>	<input type="checkbox"/>	<input type="checkbox"/>																																							
4.0A	<input type="checkbox"/>	<input type="checkbox"/>	<input type="checkbox"/>	<input type="checkbox"/>																																							
1.0 A	<table style="border-collapse: collapse;"> <tr><td>0.5A</td><td><input type="checkbox"/></td><td>OFF</td><td><input type="checkbox"/></td><td>ON</td></tr> <tr><td>1.0A</td><td><input type="checkbox"/></td><td><input type="checkbox"/></td><td><input type="checkbox"/></td><td><input type="checkbox"/></td></tr> <tr><td>2.0A</td><td><input type="checkbox"/></td><td><input type="checkbox"/></td><td><input type="checkbox"/></td><td><input type="checkbox"/></td></tr> <tr><td>4.0A</td><td><input type="checkbox"/></td><td><input type="checkbox"/></td><td><input type="checkbox"/></td><td><input type="checkbox"/></td></tr> </table>	0.5A	<input type="checkbox"/>	OFF	<input type="checkbox"/>	ON	1.0A	<input type="checkbox"/>	<input type="checkbox"/>	<input type="checkbox"/>	<input type="checkbox"/>	2.0A	<input type="checkbox"/>	<input type="checkbox"/>	<input type="checkbox"/>	<input type="checkbox"/>	4.0A	<input type="checkbox"/>	<input type="checkbox"/>	<input type="checkbox"/>	<input type="checkbox"/>	5.0 A	<table style="border-collapse: collapse;"> <tr><td>0.5A</td><td><input type="checkbox"/></td><td>OFF</td><td><input type="checkbox"/></td><td>ON</td></tr> <tr><td>1.0A</td><td><input type="checkbox"/></td><td><input type="checkbox"/></td><td><input type="checkbox"/></td><td><input type="checkbox"/></td></tr> <tr><td>2.0A</td><td><input type="checkbox"/></td><td><input type="checkbox"/></td><td><input type="checkbox"/></td><td><input type="checkbox"/></td></tr> <tr><td>4.0A</td><td><input type="checkbox"/></td><td><input type="checkbox"/></td><td><input type="checkbox"/></td><td><input type="checkbox"/></td></tr> </table>	0.5A	<input type="checkbox"/>	OFF	<input type="checkbox"/>	ON	1.0A	<input type="checkbox"/>	<input type="checkbox"/>	<input type="checkbox"/>	<input type="checkbox"/>	2.0A	<input type="checkbox"/>	<input type="checkbox"/>	<input type="checkbox"/>	<input type="checkbox"/>	4.0A	<input type="checkbox"/>	<input type="checkbox"/>	<input type="checkbox"/>	<input type="checkbox"/>
0.5A	<input type="checkbox"/>	OFF	<input type="checkbox"/>	ON																																							
1.0A	<input type="checkbox"/>	<input type="checkbox"/>	<input type="checkbox"/>	<input type="checkbox"/>																																							
2.0A	<input type="checkbox"/>	<input type="checkbox"/>	<input type="checkbox"/>	<input type="checkbox"/>																																							
4.0A	<input type="checkbox"/>	<input type="checkbox"/>	<input type="checkbox"/>	<input type="checkbox"/>																																							
0.5A	<input type="checkbox"/>	OFF	<input type="checkbox"/>	ON																																							
1.0A	<input type="checkbox"/>	<input type="checkbox"/>	<input type="checkbox"/>	<input type="checkbox"/>																																							
2.0A	<input type="checkbox"/>	<input type="checkbox"/>	<input type="checkbox"/>	<input type="checkbox"/>																																							
4.0A	<input type="checkbox"/>	<input type="checkbox"/>	<input type="checkbox"/>	<input type="checkbox"/>																																							
1.5 A	<table style="border-collapse: collapse;"> <tr><td>0.5A</td><td><input type="checkbox"/></td><td>OFF</td><td><input type="checkbox"/></td><td>ON</td></tr> <tr><td>1.0A</td><td><input type="checkbox"/></td><td><input type="checkbox"/></td><td><input type="checkbox"/></td><td><input type="checkbox"/></td></tr> <tr><td>2.0A</td><td><input type="checkbox"/></td><td><input type="checkbox"/></td><td><input type="checkbox"/></td><td><input type="checkbox"/></td></tr> <tr><td>4.0A</td><td><input type="checkbox"/></td><td><input type="checkbox"/></td><td><input type="checkbox"/></td><td><input type="checkbox"/></td></tr> </table>	0.5A	<input type="checkbox"/>	OFF	<input type="checkbox"/>	ON	1.0A	<input type="checkbox"/>	<input type="checkbox"/>	<input type="checkbox"/>	<input type="checkbox"/>	2.0A	<input type="checkbox"/>	<input type="checkbox"/>	<input type="checkbox"/>	<input type="checkbox"/>	4.0A	<input type="checkbox"/>	<input type="checkbox"/>	<input type="checkbox"/>	<input type="checkbox"/>	5.5 A	<table style="border-collapse: collapse;"> <tr><td>0.5A</td><td><input type="checkbox"/></td><td>OFF</td><td><input type="checkbox"/></td><td>ON</td></tr> <tr><td>1.0A</td><td><input type="checkbox"/></td><td><input type="checkbox"/></td><td><input type="checkbox"/></td><td><input type="checkbox"/></td></tr> <tr><td>2.0A</td><td><input type="checkbox"/></td><td><input type="checkbox"/></td><td><input type="checkbox"/></td><td><input type="checkbox"/></td></tr> <tr><td>4.0A</td><td><input type="checkbox"/></td><td><input type="checkbox"/></td><td><input type="checkbox"/></td><td><input type="checkbox"/></td></tr> </table>	0.5A	<input type="checkbox"/>	OFF	<input type="checkbox"/>	ON	1.0A	<input type="checkbox"/>	<input type="checkbox"/>	<input type="checkbox"/>	<input type="checkbox"/>	2.0A	<input type="checkbox"/>	<input type="checkbox"/>	<input type="checkbox"/>	<input type="checkbox"/>	4.0A	<input type="checkbox"/>	<input type="checkbox"/>	<input type="checkbox"/>	<input type="checkbox"/>
0.5A	<input type="checkbox"/>	OFF	<input type="checkbox"/>	ON																																							
1.0A	<input type="checkbox"/>	<input type="checkbox"/>	<input type="checkbox"/>	<input type="checkbox"/>																																							
2.0A	<input type="checkbox"/>	<input type="checkbox"/>	<input type="checkbox"/>	<input type="checkbox"/>																																							
4.0A	<input type="checkbox"/>	<input type="checkbox"/>	<input type="checkbox"/>	<input type="checkbox"/>																																							
0.5A	<input type="checkbox"/>	OFF	<input type="checkbox"/>	ON																																							
1.0A	<input type="checkbox"/>	<input type="checkbox"/>	<input type="checkbox"/>	<input type="checkbox"/>																																							
2.0A	<input type="checkbox"/>	<input type="checkbox"/>	<input type="checkbox"/>	<input type="checkbox"/>																																							
4.0A	<input type="checkbox"/>	<input type="checkbox"/>	<input type="checkbox"/>	<input type="checkbox"/>																																							
2.0 A	<table style="border-collapse: collapse;"> <tr><td>0.5A</td><td><input type="checkbox"/></td><td>OFF</td><td><input type="checkbox"/></td><td>ON</td></tr> <tr><td>1.0A</td><td><input type="checkbox"/></td><td><input type="checkbox"/></td><td><input type="checkbox"/></td><td><input type="checkbox"/></td></tr> <tr><td>2.0A</td><td><input type="checkbox"/></td><td><input type="checkbox"/></td><td><input type="checkbox"/></td><td><input type="checkbox"/></td></tr> <tr><td>4.0A</td><td><input type="checkbox"/></td><td><input type="checkbox"/></td><td><input type="checkbox"/></td><td><input type="checkbox"/></td></tr> </table>	0.5A	<input type="checkbox"/>	OFF	<input type="checkbox"/>	ON	1.0A	<input type="checkbox"/>	<input type="checkbox"/>	<input type="checkbox"/>	<input type="checkbox"/>	2.0A	<input type="checkbox"/>	<input type="checkbox"/>	<input type="checkbox"/>	<input type="checkbox"/>	4.0A	<input type="checkbox"/>	<input type="checkbox"/>	<input type="checkbox"/>	<input type="checkbox"/>	6.0 A	<table style="border-collapse: collapse;"> <tr><td>0.5A</td><td><input type="checkbox"/></td><td>OFF</td><td><input type="checkbox"/></td><td>ON</td></tr> <tr><td>1.0A</td><td><input type="checkbox"/></td><td><input type="checkbox"/></td><td><input type="checkbox"/></td><td><input type="checkbox"/></td></tr> <tr><td>2.0A</td><td><input type="checkbox"/></td><td><input type="checkbox"/></td><td><input type="checkbox"/></td><td><input type="checkbox"/></td></tr> <tr><td>4.0A</td><td><input type="checkbox"/></td><td><input type="checkbox"/></td><td><input type="checkbox"/></td><td><input type="checkbox"/></td></tr> </table>	0.5A	<input type="checkbox"/>	OFF	<input type="checkbox"/>	ON	1.0A	<input type="checkbox"/>	<input type="checkbox"/>	<input type="checkbox"/>	<input type="checkbox"/>	2.0A	<input type="checkbox"/>	<input type="checkbox"/>	<input type="checkbox"/>	<input type="checkbox"/>	4.0A	<input type="checkbox"/>	<input type="checkbox"/>	<input type="checkbox"/>	<input type="checkbox"/>
0.5A	<input type="checkbox"/>	OFF	<input type="checkbox"/>	ON																																							
1.0A	<input type="checkbox"/>	<input type="checkbox"/>	<input type="checkbox"/>	<input type="checkbox"/>																																							
2.0A	<input type="checkbox"/>	<input type="checkbox"/>	<input type="checkbox"/>	<input type="checkbox"/>																																							
4.0A	<input type="checkbox"/>	<input type="checkbox"/>	<input type="checkbox"/>	<input type="checkbox"/>																																							
0.5A	<input type="checkbox"/>	OFF	<input type="checkbox"/>	ON																																							
1.0A	<input type="checkbox"/>	<input type="checkbox"/>	<input type="checkbox"/>	<input type="checkbox"/>																																							
2.0A	<input type="checkbox"/>	<input type="checkbox"/>	<input type="checkbox"/>	<input type="checkbox"/>																																							
4.0A	<input type="checkbox"/>	<input type="checkbox"/>	<input type="checkbox"/>	<input type="checkbox"/>																																							
2.5 A	<table style="border-collapse: collapse;"> <tr><td>0.5A</td><td><input type="checkbox"/></td><td>OFF</td><td><input type="checkbox"/></td><td>ON</td></tr> <tr><td>1.0A</td><td><input type="checkbox"/></td><td><input type="checkbox"/></td><td><input type="checkbox"/></td><td><input type="checkbox"/></td></tr> <tr><td>2.0A</td><td><input type="checkbox"/></td><td><input type="checkbox"/></td><td><input type="checkbox"/></td><td><input type="checkbox"/></td></tr> <tr><td>4.0A</td><td><input type="checkbox"/></td><td><input type="checkbox"/></td><td><input type="checkbox"/></td><td><input type="checkbox"/></td></tr> </table>	0.5A	<input type="checkbox"/>	OFF	<input type="checkbox"/>	ON	1.0A	<input type="checkbox"/>	<input type="checkbox"/>	<input type="checkbox"/>	<input type="checkbox"/>	2.0A	<input type="checkbox"/>	<input type="checkbox"/>	<input type="checkbox"/>	<input type="checkbox"/>	4.0A	<input type="checkbox"/>	<input type="checkbox"/>	<input type="checkbox"/>	<input type="checkbox"/>	6.5 A	<table style="border-collapse: collapse;"> <tr><td>0.5A</td><td><input type="checkbox"/></td><td>OFF</td><td><input type="checkbox"/></td><td>ON</td></tr> <tr><td>1.0A</td><td><input type="checkbox"/></td><td><input type="checkbox"/></td><td><input type="checkbox"/></td><td><input type="checkbox"/></td></tr> <tr><td>2.0A</td><td><input type="checkbox"/></td><td><input type="checkbox"/></td><td><input type="checkbox"/></td><td><input type="checkbox"/></td></tr> <tr><td>4.0A</td><td><input type="checkbox"/></td><td><input type="checkbox"/></td><td><input type="checkbox"/></td><td><input type="checkbox"/></td></tr> </table>	0.5A	<input type="checkbox"/>	OFF	<input type="checkbox"/>	ON	1.0A	<input type="checkbox"/>	<input type="checkbox"/>	<input type="checkbox"/>	<input type="checkbox"/>	2.0A	<input type="checkbox"/>	<input type="checkbox"/>	<input type="checkbox"/>	<input type="checkbox"/>	4.0A	<input type="checkbox"/>	<input type="checkbox"/>	<input type="checkbox"/>	<input type="checkbox"/>
0.5A	<input type="checkbox"/>	OFF	<input type="checkbox"/>	ON																																							
1.0A	<input type="checkbox"/>	<input type="checkbox"/>	<input type="checkbox"/>	<input type="checkbox"/>																																							
2.0A	<input type="checkbox"/>	<input type="checkbox"/>	<input type="checkbox"/>	<input type="checkbox"/>																																							
4.0A	<input type="checkbox"/>	<input type="checkbox"/>	<input type="checkbox"/>	<input type="checkbox"/>																																							
0.5A	<input type="checkbox"/>	OFF	<input type="checkbox"/>	ON																																							
1.0A	<input type="checkbox"/>	<input type="checkbox"/>	<input type="checkbox"/>	<input type="checkbox"/>																																							
2.0A	<input type="checkbox"/>	<input type="checkbox"/>	<input type="checkbox"/>	<input type="checkbox"/>																																							
4.0A	<input type="checkbox"/>	<input type="checkbox"/>	<input type="checkbox"/>	<input type="checkbox"/>																																							
3.0 A	<table style="border-collapse: collapse;"> <tr><td>0.5A</td><td><input type="checkbox"/></td><td>OFF</td><td><input type="checkbox"/></td><td>ON</td></tr> <tr><td>1.0A</td><td><input type="checkbox"/></td><td><input type="checkbox"/></td><td><input type="checkbox"/></td><td><input type="checkbox"/></td></tr> <tr><td>2.0A</td><td><input type="checkbox"/></td><td><input type="checkbox"/></td><td><input type="checkbox"/></td><td><input type="checkbox"/></td></tr> <tr><td>4.0A</td><td><input type="checkbox"/></td><td><input type="checkbox"/></td><td><input type="checkbox"/></td><td><input type="checkbox"/></td></tr> </table>	0.5A	<input type="checkbox"/>	OFF	<input type="checkbox"/>	ON	1.0A	<input type="checkbox"/>	<input type="checkbox"/>	<input type="checkbox"/>	<input type="checkbox"/>	2.0A	<input type="checkbox"/>	<input type="checkbox"/>	<input type="checkbox"/>	<input type="checkbox"/>	4.0A	<input type="checkbox"/>	<input type="checkbox"/>	<input type="checkbox"/>	<input type="checkbox"/>	7.0 A	<table style="border-collapse: collapse;"> <tr><td>0.5A</td><td><input type="checkbox"/></td><td>OFF</td><td><input type="checkbox"/></td><td>ON</td></tr> <tr><td>1.0A</td><td><input type="checkbox"/></td><td><input type="checkbox"/></td><td><input type="checkbox"/></td><td><input type="checkbox"/></td></tr> <tr><td>2.0A</td><td><input type="checkbox"/></td><td><input type="checkbox"/></td><td><input type="checkbox"/></td><td><input type="checkbox"/></td></tr> <tr><td>4.0A</td><td><input type="checkbox"/></td><td><input type="checkbox"/></td><td><input type="checkbox"/></td><td><input type="checkbox"/></td></tr> </table>	0.5A	<input type="checkbox"/>	OFF	<input type="checkbox"/>	ON	1.0A	<input type="checkbox"/>	<input type="checkbox"/>	<input type="checkbox"/>	<input type="checkbox"/>	2.0A	<input type="checkbox"/>	<input type="checkbox"/>	<input type="checkbox"/>	<input type="checkbox"/>	4.0A	<input type="checkbox"/>	<input type="checkbox"/>	<input type="checkbox"/>	<input type="checkbox"/>
0.5A	<input type="checkbox"/>	OFF	<input type="checkbox"/>	ON																																							
1.0A	<input type="checkbox"/>	<input type="checkbox"/>	<input type="checkbox"/>	<input type="checkbox"/>																																							
2.0A	<input type="checkbox"/>	<input type="checkbox"/>	<input type="checkbox"/>	<input type="checkbox"/>																																							
4.0A	<input type="checkbox"/>	<input type="checkbox"/>	<input type="checkbox"/>	<input type="checkbox"/>																																							
0.5A	<input type="checkbox"/>	OFF	<input type="checkbox"/>	ON																																							
1.0A	<input type="checkbox"/>	<input type="checkbox"/>	<input type="checkbox"/>	<input type="checkbox"/>																																							
2.0A	<input type="checkbox"/>	<input type="checkbox"/>	<input type="checkbox"/>	<input type="checkbox"/>																																							
4.0A	<input type="checkbox"/>	<input type="checkbox"/>	<input type="checkbox"/>	<input type="checkbox"/>																																							
3.5 A	<table style="border-collapse: collapse;"> <tr><td>0.5A</td><td><input type="checkbox"/></td><td>OFF</td><td><input type="checkbox"/></td><td>ON</td></tr> <tr><td>1.0A</td><td><input type="checkbox"/></td><td><input type="checkbox"/></td><td><input type="checkbox"/></td><td><input type="checkbox"/></td></tr> <tr><td>2.0A</td><td><input type="checkbox"/></td><td><input type="checkbox"/></td><td><input type="checkbox"/></td><td><input type="checkbox"/></td></tr> <tr><td>4.0A</td><td><input type="checkbox"/></td><td><input type="checkbox"/></td><td><input type="checkbox"/></td><td><input type="checkbox"/></td></tr> </table>	0.5A	<input type="checkbox"/>	OFF	<input type="checkbox"/>	ON	1.0A	<input type="checkbox"/>	<input type="checkbox"/>	<input type="checkbox"/>	<input type="checkbox"/>	2.0A	<input type="checkbox"/>	<input type="checkbox"/>	<input type="checkbox"/>	<input type="checkbox"/>	4.0A	<input type="checkbox"/>	<input type="checkbox"/>	<input type="checkbox"/>	<input type="checkbox"/>	7.5 A	<table style="border-collapse: collapse;"> <tr><td>0.5A</td><td><input type="checkbox"/></td><td>OFF</td><td><input type="checkbox"/></td><td>ON</td></tr> <tr><td>1.0A</td><td><input type="checkbox"/></td><td><input type="checkbox"/></td><td><input type="checkbox"/></td><td><input type="checkbox"/></td></tr> <tr><td>2.0A</td><td><input type="checkbox"/></td><td><input type="checkbox"/></td><td><input type="checkbox"/></td><td><input type="checkbox"/></td></tr> <tr><td>4.0A</td><td><input type="checkbox"/></td><td><input type="checkbox"/></td><td><input type="checkbox"/></td><td><input type="checkbox"/></td></tr> </table>	0.5A	<input type="checkbox"/>	OFF	<input type="checkbox"/>	ON	1.0A	<input type="checkbox"/>	<input type="checkbox"/>	<input type="checkbox"/>	<input type="checkbox"/>	2.0A	<input type="checkbox"/>	<input type="checkbox"/>	<input type="checkbox"/>	<input type="checkbox"/>	4.0A	<input type="checkbox"/>	<input type="checkbox"/>	<input type="checkbox"/>	<input type="checkbox"/>
0.5A	<input type="checkbox"/>	OFF	<input type="checkbox"/>	ON																																							
1.0A	<input type="checkbox"/>	<input type="checkbox"/>	<input type="checkbox"/>	<input type="checkbox"/>																																							
2.0A	<input type="checkbox"/>	<input type="checkbox"/>	<input type="checkbox"/>	<input type="checkbox"/>																																							
4.0A	<input type="checkbox"/>	<input type="checkbox"/>	<input type="checkbox"/>	<input type="checkbox"/>																																							
0.5A	<input type="checkbox"/>	OFF	<input type="checkbox"/>	ON																																							
1.0A	<input type="checkbox"/>	<input type="checkbox"/>	<input type="checkbox"/>	<input type="checkbox"/>																																							
2.0A	<input type="checkbox"/>	<input type="checkbox"/>	<input type="checkbox"/>	<input type="checkbox"/>																																							
4.0A	<input type="checkbox"/>	<input type="checkbox"/>	<input type="checkbox"/>	<input type="checkbox"/>																																							
4.0 A	<table style="border-collapse: collapse;"> <tr><td>0.5A</td><td><input type="checkbox"/></td><td>OFF</td><td><input type="checkbox"/></td><td>ON</td></tr> <tr><td>1.0A</td><td><input type="checkbox"/></td><td><input type="checkbox"/></td><td><input type="checkbox"/></td><td><input type="checkbox"/></td></tr> <tr><td>2.0A</td><td><input type="checkbox"/></td><td><input type="checkbox"/></td><td><input type="checkbox"/></td><td><input type="checkbox"/></td></tr> <tr><td>4.0A</td><td><input type="checkbox"/></td><td><input type="checkbox"/></td><td><input type="checkbox"/></td><td><input type="checkbox"/></td></tr> </table>	0.5A	<input type="checkbox"/>	OFF	<input type="checkbox"/>	ON	1.0A	<input type="checkbox"/>	<input type="checkbox"/>	<input type="checkbox"/>	<input type="checkbox"/>	2.0A	<input type="checkbox"/>	<input type="checkbox"/>	<input type="checkbox"/>	<input type="checkbox"/>	4.0A	<input type="checkbox"/>	<input type="checkbox"/>	<input type="checkbox"/>	<input type="checkbox"/>																						
0.5A	<input type="checkbox"/>	OFF	<input type="checkbox"/>	ON																																							
1.0A	<input type="checkbox"/>	<input type="checkbox"/>	<input type="checkbox"/>	<input type="checkbox"/>																																							
2.0A	<input type="checkbox"/>	<input type="checkbox"/>	<input type="checkbox"/>	<input type="checkbox"/>																																							
4.0A	<input type="checkbox"/>	<input type="checkbox"/>	<input type="checkbox"/>	<input type="checkbox"/>																																							

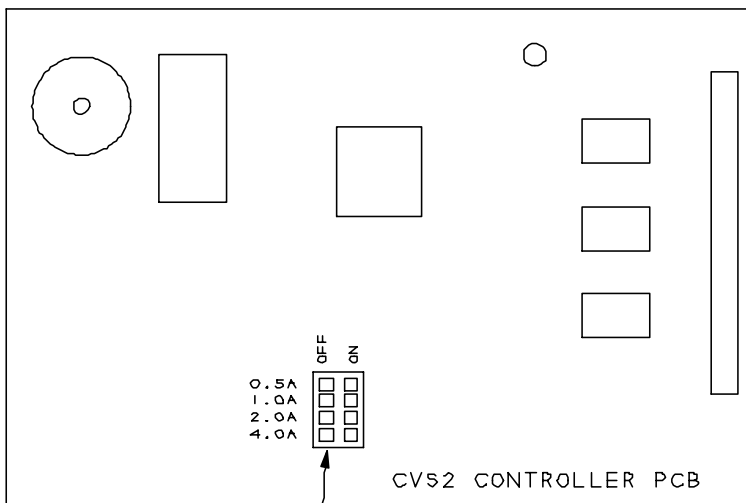

LIQUID PUMP
INPUT CURRENT
TRIGGER THRESHOLD
SETTING

IE-VR024

7.0 Other Requirements

7.1 Other Electrical Requirements

1. Seal-offs are required as per NPFA 70 (National Electrical Code) for a conduit run leaving a Division 1 or 2 location to an unclassified location. Install as required by NEC and local authority having jurisdiction. Other seal-offs may be necessary based on the installation and site specifics.
2. Seal-offs should be installed in the conduit for the Vapor Pump and the Tank Pressure Switch. Always follow the Hazardous Location requirements of the local and national authorities.
3. Ensure the use of an earth ground for circuits.
4. Use a dedicated two pole circuit breaker for power to the CVS2 System.
5. Use metallic conduit.
6. Install a dedicated ground wire from the CVS2 Vapor Pump to the CVS2 Controller, to the Load Center, and to earth ground; do not rely on metallic conduit to supply a reliable and safe ground path.
7. If a liquid pump fails and must be replaced, bypass the CVS2 input channel while testing the new liquid pump. If in the event the failed liquid pump damages a CVS2 input channel, once the new pump is installed and tested, connect it to a new input channel.

7.2 Storage Tank Overfill Devices

Storage tank over fill prevention devices should be used to ensure that in the event of an overfill liquid gasoline does not enter the Vapor Pump. Damage may occur, and may result in a hazardous condition.

7.3 P/V Valve

1. Required minimum one per site (always verify requirements of the local authorities). Use an Approved valve that meets all local regulations and requirements.
2. Recommended pressure setting: +3" wc / -8" wc.

7.4 Controller Communications

1. Communication Settings
 - a. Use HyperTerminal (or similar) with the following settings:
 1. Bits per seconds: 19200
 2. Data bits: 8
 3. Parity: None
 4. Stop bit: 1
 5. Flow Control: None
 - b. Once communication is established key in the command followed by 'Enter'.
2. Data Collection
 - a. All data is stored for 60 days with rotary memory.
 - b. Vapor pump total running minutes per day.
 - c. Vapor pump total run counts per day.
 - d. Alarm/Event Record; last 20 events.
 - e. Alarm with date and time.
 - f. Reset with data and time.

- g. Venting total minutes per day (as logged from Vent Monitor switch closed duration, if installed).
- h. Venting counts per day (as logged from Vent Monitor switch closed counts, if installed).
- i. Logged memory is held in the event of a power failure.

7.5 Data Commands

1. Retrieve vapor pump information. Command: 123

OPW Central Vacuum Stage II Vapor Recovery System		
VAPOR PUMP INFORMATION		
DATE (DD/MM/YY)	MINUTES	COUNT
02/03/05	458	24
01/03/05	257	15
28/02/05	845	50
27/02/05	685	35

2. Retrieve vent information. Command: 124

OPW Central Vacuum Stage II Vapor Recovery System		
VENT INFORMATION		
DATE (DD/MM/YY)	MINUTES	COUNT
02/03/05	2	1
01/03/05	27	5
28/02/05	0	0
27/02/05	12	3

3. Retrieve alarm/event information. Command: 125

OPW Central Vacuum Stage II Vapor Recovery System		
ALARM/EVENT INFORMATION		
DATE (DD/MM/YY)	TIME	EVENT
02/03/05	15:35	RESET
01/03/05	02:47	PUMP
28/02/05	12:56	RESET
27/02/05	22:03	RESET

4. Set Date. Command: 126

Note: A date must be entered even if the current date is correct. Do not enter “ / ” between fields. If no date is entered, a random date will appear.

OPW Central Vacuum Stage II Vapor Recovery System	
The Date is 14/11/05	
SET DATE (DDMMYY)?	

The Controller will respond with the date entered:

The Date is 14/11/05

5. Set Time. Command: 127

Note: A time must be entered even if the current time is correct. Do not enter “ : ” between fields. If no time is entered, a random time will appear. Use 24 hour clock.

OPW Central Vacuum Stage II Vapor Recovery System	
The Time is 13:26	
SET DATE (HHMM)?	

The Controller will respond with the time entered:

The Time is 13:26

8.0 A/L Adjustments

1. To measure A/L use a VacuSmart, VacuChek, or other approved device or method.
2. The A/L setting is accomplished by adjusting the regulator screw with a 3/16" hex wrench.
3. The A/L regulator screw is locked by a 9/16" hex nut.
4. Initial setting of the A/L on each fueling point should be made with no other dispensing occurring at the facility. Always set A/L at the maximum liquid flow rate possible at each fueling point. It is recommended that the filters be changed before setting the A/L.
5. To set A/L:
 - a. Measure A/L (with no others dispensing).
 - b. If A/L is outside the allowable range, loosen the lock nut while holding the Regulating Screw.
 - c. To lower the A/L tighten the Regulating Screw (clockwise); to raise the A/L loosen the Regulating Screw (counter-clockwise).
 - d. Hold the Regulating Screw and snug the lock nut.
 - e. Re-measure A/L.
 - f. DO NOT loosen the Regulating Screw past the limit groove machined into the Regulating Screw.
6. A/L initial setting should be nominal 0.95 (0.90-1.00).

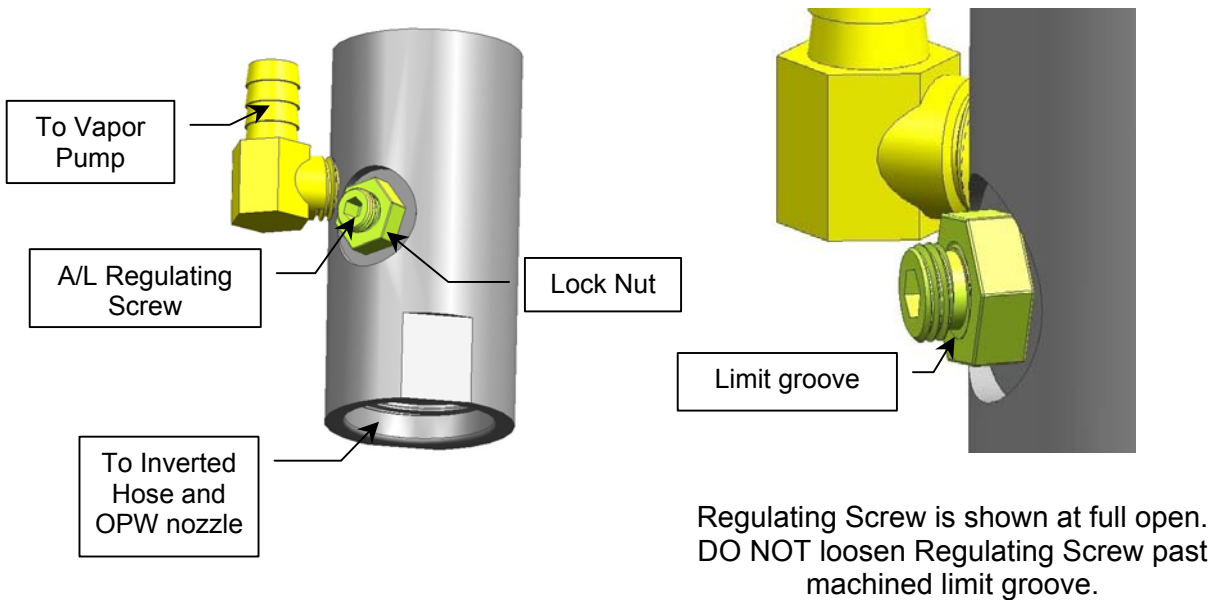

Note: A/L is defined as - Air to liquid volume ratio. With any vapor recovery system A/L relates to the volume of air (or vapor) returned by the vapor recovery system (usually measured in Cubic Ft.) divided by the volume of liquid dispensed (7.481 Gallons U.S. = 1 Cubic Ft.; 28.317 Liters = 1 Cubic Ft.).

Easy Set A/L with VacuChek

1. Measure liquid flow rate on hose point (at maximum flow).
2. From the VacuChek A/L tables, find the measured liquid flow rate (bottom of each column), or seconds for 2 gallons (top of each column).
3. In that column find the Table A/L.
Use the VacuChek correction factor:
$$\text{Table A/L} = \text{Final A/L} \text{ divided by VacuChek Correction Factor.}$$
4. Go to the left column to find the required "Flow Units" needed on the VacuChek gage for the final A/L.
5. Install the VacuChek "airflow sensor" on the nozzle spout covering the vapor holes (do not cover the shut-off port, be sure to read and follow all instructions in the VacuChek Manual).
6. Begin dispensing gasoline (at maximum flow) into a grounded container approved for gasoline.
7. While dispensing, adjust the CVS2 A/L regulator to obtain the required "Flow Units" on the VacuChek gage.
8. Once the correct "Flow Units" is achieved, lock the A/L regulator adjustment screw with the lock nut.

See next page for example.

Easy Set A/L Example:

1. Liquid flow rate is measured at 10.0 GPM (12.0 seconds for 2 gallons).
2. The final A/L is to be set at 0.95.
3. The VacuChek being used has a Correction Factor of 1.03
4. Calculate the Table A/L: Table A/L = 0.95/1.03 = 0.92.
5. Find 0.92 in the column for 10.0 GPM.
6. Find the "Flow Unit" required to obtain this A/L: Flow Unit = 0.34.
7. Install the VacuChek "air flow sensor" and begin dispensing at full flow.
8. Adjust the A/L regulator until the VacuChek gage shows 0.34.
9. Tighten A/L Regulator lock nut.
10. A/L is now set at 0.95.

Example table for VacuChek

SECONDS PER 2 GAL	11.7	11.8	11.9	12.0	12.1	12.2	12.3	12.4	12.5	12.6	12.7	12.8
SECONDS PER 8 L	12.4	12.5	12.6	12.7	12.8	12.9	13.0	13.1	13.2	13.3	13.4	13.5
FLOW UNIT												
0.02	0.12	0.12	0.12	0.12	0.12	0.12	0.12	0.12	0.12	0.12	0.13	0.13
0.04	0.23	0.23	0.24	0.24	0.24	0.24	0.24	0.24	0.25	0.25	0.25	0.25
0.06	0.32	0.32	0.32	0.33	0.33	0.33	0.33	0.34	0.34	0.34	0.34	0.35
0.08	0.40	0.40	0.41	0.41	0.41	0.42	0.42	0.42	0.43	0.43	0.43	0.44
0.10	0.47	0.48	0.48	0.49	0.49	0.49	0.50	0.50	0.51	0.51	0.51	0.52
0.12	0.52	0.52	0.52	0.53	0.53	0.54	0.54	0.55	0.55	0.56	0.56	0.56
0.14	0.56	0.56	0.57	0.57	0.58	0.58	0.59	0.59	0.60	0.60	0.61	0.61
0.16	0.60	0.60	0.61	0.62	0.62	0.63	0.63	0.64	0.64	0.65	0.65	0.66
0.18	0.64	0.65	0.65	0.66	0.66	0.67	0.67	0.68	0.69	0.69	0.70	0.70
0.20	0.68	0.69	0.70	0.70	0.71	0.71	0.72	0.72	0.73	0.74	0.74	0.75
0.22	0.72	0.72	0.73	0.74	0.74	0.75	0.75	0.76	0.77	0.77	0.78	0.79
0.24	0.75	0.76	0.76	0.77	0.78	0.78	0.79	0.80	0.80	0.81	0.82	0.82
0.26	0.78	0.79	0.80	0.80	0.81	0.82	0.82	0.83	0.84	0.85	0.85	0.86
0.28	0.82	0.83	0.83	0.84	0.85	0.85	0.86	0.87	0.87	0.88	0.89	0.90
0.30	0.85	0.86	0.87	0.87	0.88	0.89	0.90	0.90	0.91	0.92	0.92	0.93
0.32	0.88	0.88	0.89	0.90	0.91	0.91	0.92	0.93	0.94	0.94	0.95	0.96
0.34	0.90	0.91	0.92	0.92	0.93	0.94	0.95	0.96	0.96	0.97	0.98	0.99
0.36	0.93	0.93	0.94	0.95	0.96	0.97	0.97	0.98	0.99	1.00	1.01	1.01
0.38	0.95	0.96	0.97	0.98	0.98	0.99	1.00	1.01	1.02	1.02	1.03	1.04
0.40	0.98	0.98	0.99	1.00	1.01	1.02	1.03	1.03	1.04	1.05	1.06	1.07
0.42	1.00	1.01	1.02	1.02	1.03	1.04	1.05	1.06	1.07	1.08	1.08	1.09
0.44	1.02	1.03	1.04	1.05	1.06	1.07	1.07	1.08	1.09	1.10	1.11	1.12
0.46	1.04	1.05	1.06	1.07	1.08	1.09	1.10	1.11	1.12	1.13	1.13	1.14
0.48	1.07	1.08	1.09	1.10	1.10	1.11	1.12	1.13	1.14	1.15	1.16	1.17
0.50	1.09	1.10	1.11	1.12	1.13	1.14	1.15	1.16	1.17	1.17	1.18	1.19
0.52	1.11	1.12	1.13	1.14	1.15	1.16	1.17	1.18	1.19	1.20	1.21	1.22
0.54	1.13	1.14	1.15	1.16	1.17	1.18	1.19	1.20	1.21	1.22	1.23	1.24
0.56	1.15	1.16	1.17	1.18	1.19	1.20	1.21	1.22	1.23	1.24	1.25	1.26
0.58	1.17	1.18	1.19	1.20	1.21	1.22	1.23	1.24	1.25	1.26	1.27	1.28
0.60	1.19	1.20	1.21	1.22	1.23	1.24	1.26	1.27	1.28	1.29	1.30	1.31
0.62	1.21	1.22	1.23	1.24	1.25	1.27	1.28	1.29	1.30	1.31	1.32	1.33
0.64	1.23	1.24	1.25	1.26	1.28	1.29	1.30	1.31	1.32	1.33	1.34	1.35
0.66	1.25	1.26	1.27	1.28	1.30	1.31	1.32	1.33	1.34	1.35	1.36	1.37
0.68	1.27	1.28	1.29	1.30	1.32	1.33	1.34	1.35	1.36	1.37	1.38	1.39
0.70	1.29	1.30	1.31	1.32	1.34	1.35	1.36	1.37	1.38	1.39	1.40	1.41
0.72	1.31	1.32	1.33	1.34	1.35	1.37	1.38	1.39	1.40	1.41	1.42	1.43
0.74	1.33	1.34	1.35	1.36	1.37	1.39	1.40	1.41	1.42	1.43	1.44	1.45
0.76	1.35	1.36	1.37	1.38	1.39	1.40	1.42	1.43	1.44	1.45	1.46	1.47
0.78	1.37	1.38	1.39	1.40	1.41	1.42	1.44	1.45	1.46	1.47	1.48	1.49
0.80	1.38	1.40	1.41	1.42	1.43	1.44	1.46	1.47	1.48	1.49	1.50	1.51
0.82	1.40	1.41	1.43	1.44	1.45	1.46	1.47	1.49	1.50	1.51	1.52	1.53
0.84	1.42	1.43	1.44	1.46	1.47	1.48	1.49	1.50	1.52	1.53	1.54	1.55
0.86	1.44	1.45	1.46	1.47	1.49	1.50	1.51	1.52	1.54	1.55	1.56	1.57
0.88	1.45	1.47	1.48	1.49	1.50	1.52	1.53	1.54	1.55	1.57	1.58	1.59
0.90	1.47	1.48	1.50	1.51	1.52	1.53	1.55	1.56	1.57	1.59	1.60	1.61
0.92	1.48	1.50	1.51	1.52	1.53	1.55	1.56	1.57	1.59	1.60	1.61	1.62
0.94	1.50	1.51	1.52	1.53	1.55	1.56	1.57	1.59	1.60	1.61	1.62	1.64
0.96	1.51	1.52	1.53	1.55	1.56	1.57	1.59	1.60	1.61	1.63	1.64	1.65
0.98	1.52	1.53	1.55	1.56	1.57	1.59	1.60	1.61	1.63	1.64	1.65	1.66
1.00	1.53	1.55	1.56	1.57	1.59	1.60	1.61	1.63	1.64	1.65	1.66	1.68
GPM	10.26	10.17	10.08	10.00	9.92	9.84	9.76	9.68	9.60	9.52	9.45	9.38
LPM	38.77	38.44	38.12	37.80	37.49	37.18	36.88	36.58	36.29	36.00	35.72	35.44

WARNING:
DISCONNECT ALL POWER BEFORE MAKING ANY CONNECTIONS. TO PREVENT SHOCK, SERIOUS INJURY OR DEATH.

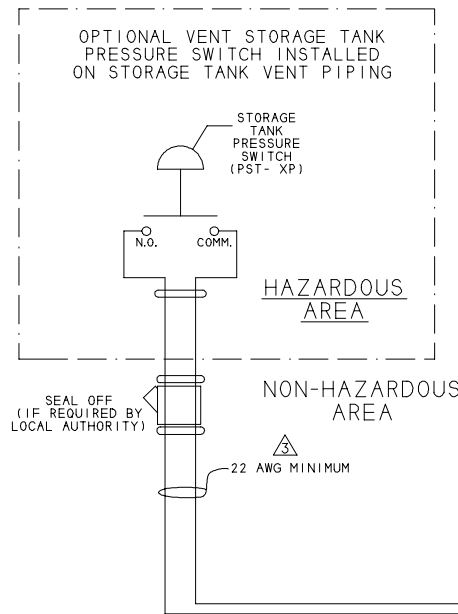

WARNING:
DISCONNECT ALL POWER BEFORE MAKING ANY CONNECTIONS. TO PREVENT SHOCK, SERIOUS INJURY OR DEATH.

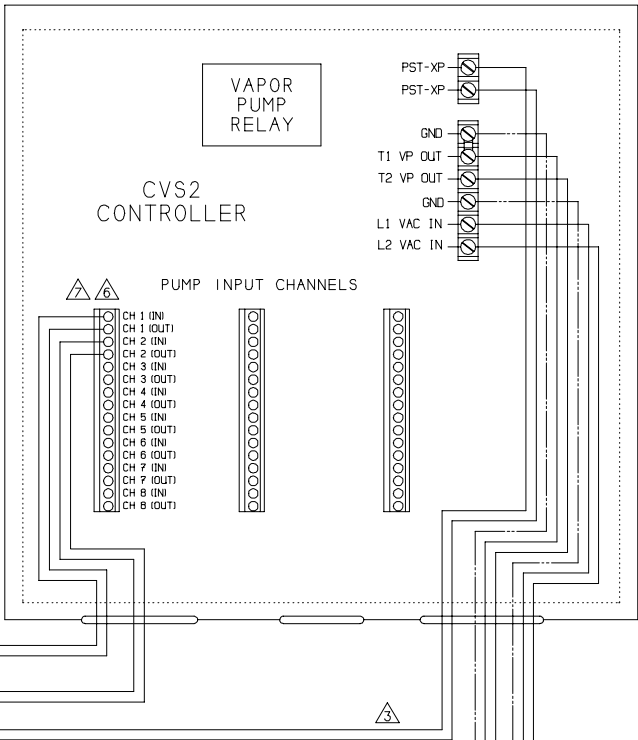
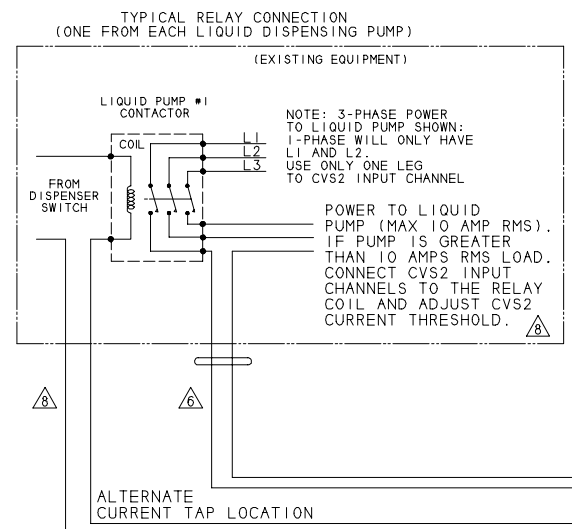

WARNING:
DISCONNECT ALL POWER BEFORE MAKING ANY CONNECTIONS. TO PREVENT SHOCK, SERIOUS INJURY OR DEATH.

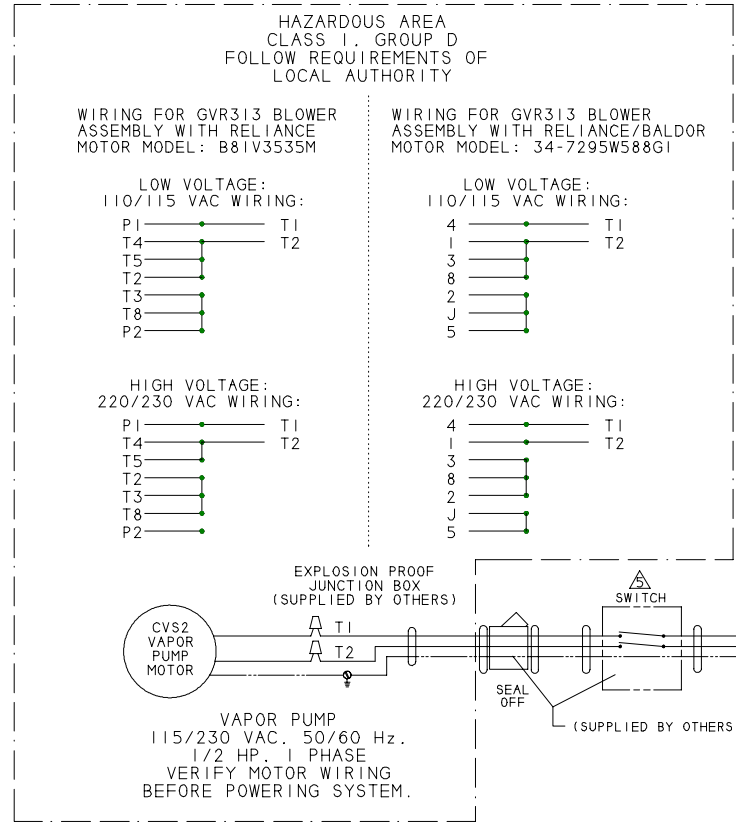

VAPOR PUMP POWER MINIMUM 12 AWG

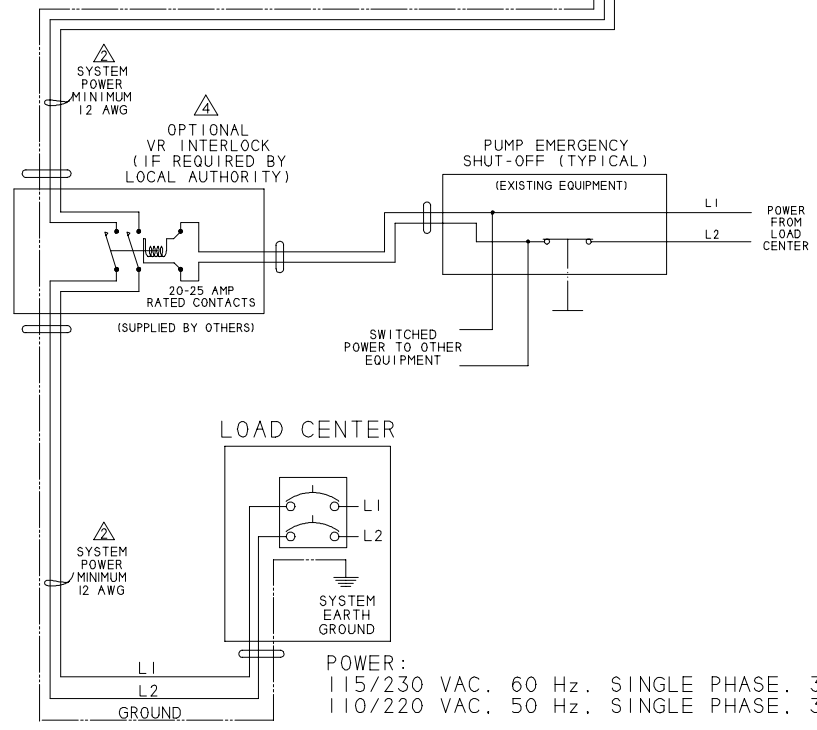

POWER:
115/230 VAC, 60 Hz, SINGLE PHASE, 3/4 AMP PLUS 1/2 HP
110/220 VAC, 50 Hz, SINGLE PHASE, 3/4 AMP PLUS 1/2 HP

WARNING:
DISCONNECT ALL POWER BEFORE MAKING ANY CONNECTIONS. TO PREVENT SHOCK, SERIOUS INJURY OR DEATH.

NOTES:

- ALWAYS FOLLOW THE REQUIREMENTS OF THE NEC, NFPA AND THE LOCAL AUTHORITIES HAVING JURISDICTION.
- ALL WIRES BETWEEN CONTROLLER AND VAPOR PUMP MUST BE TFFN OR THHN GASOLINE AND OIL RESISTANT WITH 600 V INSULATION.
- POWER WIRES TO THE MOTOR MUST BE MINIMUM 12 AWG. FOLLOW NEC REQUIREMENTS FOR WIRE AMPERAGE CAPACITY FOR THE SPECIFIC LOADING AND WIRE RUN DISTANCE TO DETERMINE IF A LARGER GAGE WIRE IS NECESSARY. MAXIMUM 5% VOLTAGE DROP.
- LOW VOLTAGE (PST-XP) WIRING MUST BE MINIMUM 22 AWG. TFFN OR THHN GASOLINE AND OIL RESISTANT WITH 600 V INSULATION.
- IF REQUIRED BY THE LOCAL AUTHORITY HAVING JURISDICTION, THE POWER TO THE SYSTEM MUST BE INTERRUPTED BY ACTIVATION OF THE PUMP EMERGENCY SHUT-OFF SWITCH.
- A LOCKABLE TWO POLE DISCONNECT SWITCH SHALL BE INSTALLED WITHIN SIGHT AND REACH OF THE MOTOR LOCATION. IF INSTALLED WITHIN THE HAZARDOUS LOCATION, IT MUST MEET ALL NEC AND LOCAL REQUIREMENTS FOR HAZARDOUS LOCATION.
- LIQUID PUMP MOTOR CURRENT MUST NOT EXCEED 15 AMPS RMS INTO CVS2 CONTROLLER PUMP INPUT CHANNELS.
- INPUT CURRENT TRIGGER THRESHOLD TO ACTIVATE THE VAPOR PUMP IS ADJUSTABLE BETWEEN 0.5 AMP AND 7.5 AMP. SEE INSTALLATION MANUAL FOR VAPOR PUMP TRIGGER ADJUSTMENT PROCEDURE.
- IF LIQUID PUMP LOAD IS GREATER THAN 10 AMPS (RMS), AN ALTERNATE SENSING LOCATION IS POSSIBLE BY MONITORING THE LIQUID PUMP RELAY COIL ACTIVATION. THE COIL'S CURRENT LOAD MUST BE GREATER THAN 0.5 AMPS AND THE CVS2 CURRENT TRIGGER MUST BE ADJUSTED. SEE INSTALLATION MANUAL FOR VAPOR PUMP TRIGGER ADJUSTMENT PROCEDURE.

WARNING:

DISCONNECT ALL POWER BEFORE MAKING ANY CONNECTIONS. TO PREVENT SHOCK, SERIOUS INJURY OR DEATH.

OPW PRODUCTS SHOULD BE USED IN COMPLIANCE WITH APPLICABLE FEDERAL, STATE, PROVINCIAL, AND LOCAL LAWS AND REGULATIONS.

FAILURE TO COMPLY WITH ALL APPLICABLE REGULATIONS AND ALL REQUIREMENTS IN THE INSTALLATION MANUAL COULD RESULT IN DEATH, SERIOUS INJURY, ELECTROCUTION, EXPLOSION, FIRE OR PROPERTY DAMAGE.

Letter	Done	Draft
D	7/20/07	JMG
C	04/09/07	JMG
B	06/05/07	JMG
A	10/27/06	JMG
CHANGES		

CVS2 SYSTEM ELECTRICAL INTERCONNECT

THIRD ANGLE PROJECTION

DRAIN: JMG
APPROVED: JMG

SCALE: NONE
DATE: 10/19/05

DRAWING NO. IE-VR023