



POMECO Installation and Maintenance Instructions

211-RMOT Remote Fill Spill Container

IMPORTANT: Please read these warnings and use the assembly instructions completely and carefully before starting. Failure to do so may cause product failure, or result in environmental contamination due to liquid leakage into the soil, creating hazardous spill conditions.

IMPORTANT: Check to make sure the unit is intact and undamaged and all parts have been supplied. Never substitute parts for those supplied. Doing so may cause product failure.

WARNING-DANGER: Using electrically operated equipment near gasoline or gasoline vapors may result in a fire or explosion, causing personal injury and property damage. Be sure that the working area is free from such hazards, and always use proper precautions.

NOTE: At all times when product is in the storage tank keep the riser pipe capped, so the vapors cannot escape into the environment.

Notice: OPW products must be used in compliance with applicable federal, state, and local laws and regulations. Product selection should be based on physical specifications and limitations and compatibility with the environment and material to be handled. All illustrations and specifications in this literature are based on the latest production information available at the time of publication. Prices, materials, and specification are subject to change at any time, and models may be discontinued at any time, in either case, without notice or obligation.

Standard Product Warranty

OPW warrants that products sold by it are free from defects in materials and workmanship for a period of one year from the date of manufacture by OPW (ECO products two years from date of manufacture.) Proof of purchase may be required. As the exclusive remedy under this limited warranty, OPW, will at its sole discretion, repair, replace, or issue credit for future orders for any product that may prove defective within the one year date of manufacture period (repairs, replacements, or credits may be subject to prorated warranty for remainder of the original warranty period, complete proper warranty claim documentation required.) This warranty shall not apply to any product that has been altered in any way, which has been repaired by any party other than a service representative authorized by OPW, or when failure is due to misuse, or improper installation or maintenance. OPW shall have no liability whatsoever for special, incidental or consequential damages to any party, and shall have no liability for the cost of labor, freight, excavation, clean up, downtime, removal, reinstallation, loss of profit, or any

other cost or charges.

For any product certified to California 2001 standards, OPW warrants that product sold by it are free from defects in material and workmanship for a period of one year from date of manufacture or one year from date of registration of installation not to exceed 15 months from date of manufacture by OPW.

THIS WARRANTY IS IN LIEU OF ALL OTHER WARRANTIES, EXPRESS OR IMPLIED, AND SPECIFICALLY THE WARRANTIES OF MERCHANTABILITY AND FITNESS FOR A PARTICULAR PURPOSE. THERE ARE NO WARRANTIES, WHICH EXTEND BEYOND THE DESCRIPTION ON THE FACE HEREOF.

211-RMOT Remote Fill Spill Container

Kit consists of:

- 1 Spill container Box
- 4 2" X 2" outer legs
- 4 Sliding legs
- 4 Feet
- 1 Lockable Drain Valve
- 1 Hardware Kit

All parts are in one box

211-RMOT Remote Fill Spill Container Installation Instructions

1. Install the drain valve by threading it into the bottom of the containment box. (See Figure 1.)

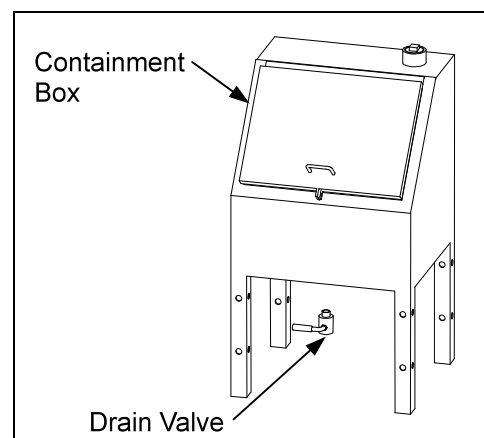

Figure 1

2. The legs are shipped with the small legs inside the outer legs. Using the included 3/8 – 16 bolts (quantity eight), bolt the large legs to the flanges

on the bottom of the containment box. (See Figure 2.)

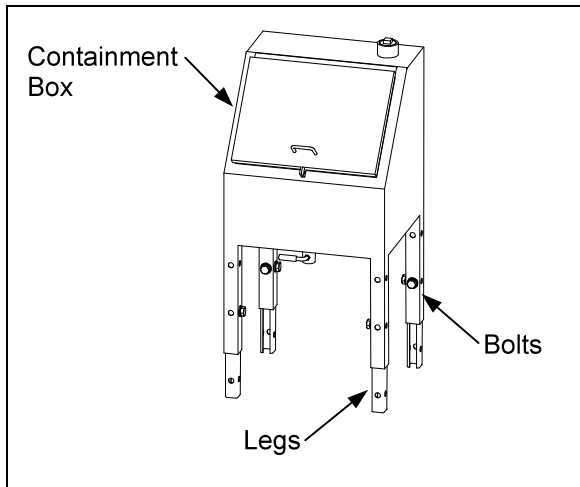

Figure 2

3. Using the included hardware, bolt the feet to the bottom of the legs. (See Figure 3.)

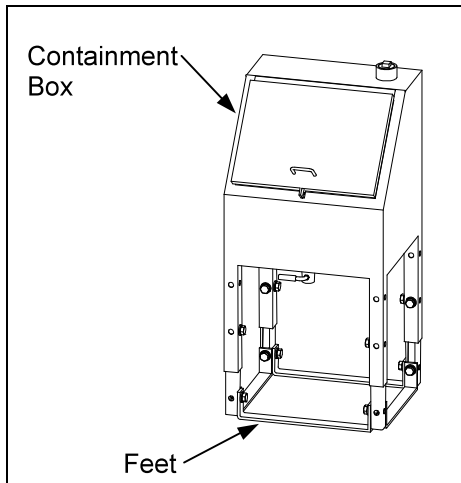

Figure 3

4. Adjust the legs to the required height.

5. Place the spill container in the desired location and, to assure a tight fit to the pipe, tighten the stainless steel clamp on the Buna-N boot. (See Figure 4.)

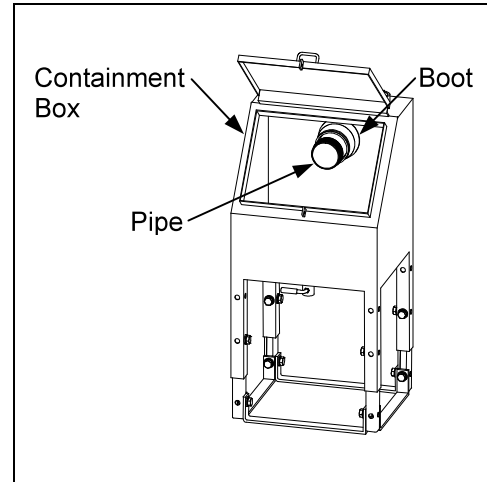

Figure 4

6. Make final adjustments to the legs.

7. Check the valve for tightness by pouring water into the box.



ONE COMPANY. ONE WORLD. ONE SOURCE.

P.O. Box 405003 * Cincinnati, Ohio 45240-5003
1-800-422-2525 Domestically
513-870-3315 Internationally

Marketing Agent for POMEKO by OPW, Inc.
Copyright, 2005 – OPW Fueling Components Inc., Cincinnati, OH
Printed in U.S.A. p/n H15857PA – 2/05