

Equipment: Torsion Balance Type: 790A,B,C

Balance Unit for balancing Loading Arms

Suitable for: Loading Arm Balancing

- Easy, Precise Adjustment
- No special tools required

Specifications

Type Right-Hand: 790A-0020 (White),
790B-0030 (Yellow), 790C-0050 (Red)
Left-Hand: 790ALH-0025 (Black),
790BLH-0035 (Gray), 790CLH (Orange)

Working Temperature Range -4°F to 176°F (-20°C to +80°C)



NEW: Easy-to-use Spring Cover Latch

Installation

Spring Unit Assembly

1. Position balance unit on the bosses at back of swivel joint.
2. Fix balance unit with Bolts and Lock Washers.
3. Attach backside of Link Arm [17] to Spring Arm [15] with Pin [16] and 2 Retaining Rings [14].
4. Remove the 4 Socket Head Screws [18] and take Snubber Block [26] off.
5. Raise loading arm to highest position (as vertical as possible).
6. Attach front side of Link Arm [17] to mounting ears on loading arm with Pin [16] and 2 Retaining Rings [14].
7. Check balancing action by pulling down the arm. If adjustment is necessary, follow adjustment instructions below.
8. Install lock-down unit 788-L, if used, by following 788-L installation instructions.
9. Replace Cover [21] using alignment pins [1] and latches [22].

Adjustment

When to adjust torque

- A. To raise loading arm higher or for more lifting action INCREASE torque.
- B. To decrease loading arm vertical travel or to slow the rate at which the arm rises, DECREASE torque.
- C. Note: Prior to any disassembly, Spring balance tension should be completely relieved to allow safe disassembly of level arm.

Torque

For more lifting action increase torque. For less lifting action decrease torque.

Place 3/4" socket wrench on worm gear hex drive.

To **INCREASE** torque rotate the worm gear hex drive counterclockwise (to the left).



To **DECREASE** torque rotate the worm gear hex drive clockwise (to the right).

Release wrench and test loading arm lifting action.

Note: Prior to any loading arm disassembly, spring tension should be completely relieved.

Tip: Spring coil will be loose in housing when completely relieved of tension.

Parts List: 790 Series Counterbalance

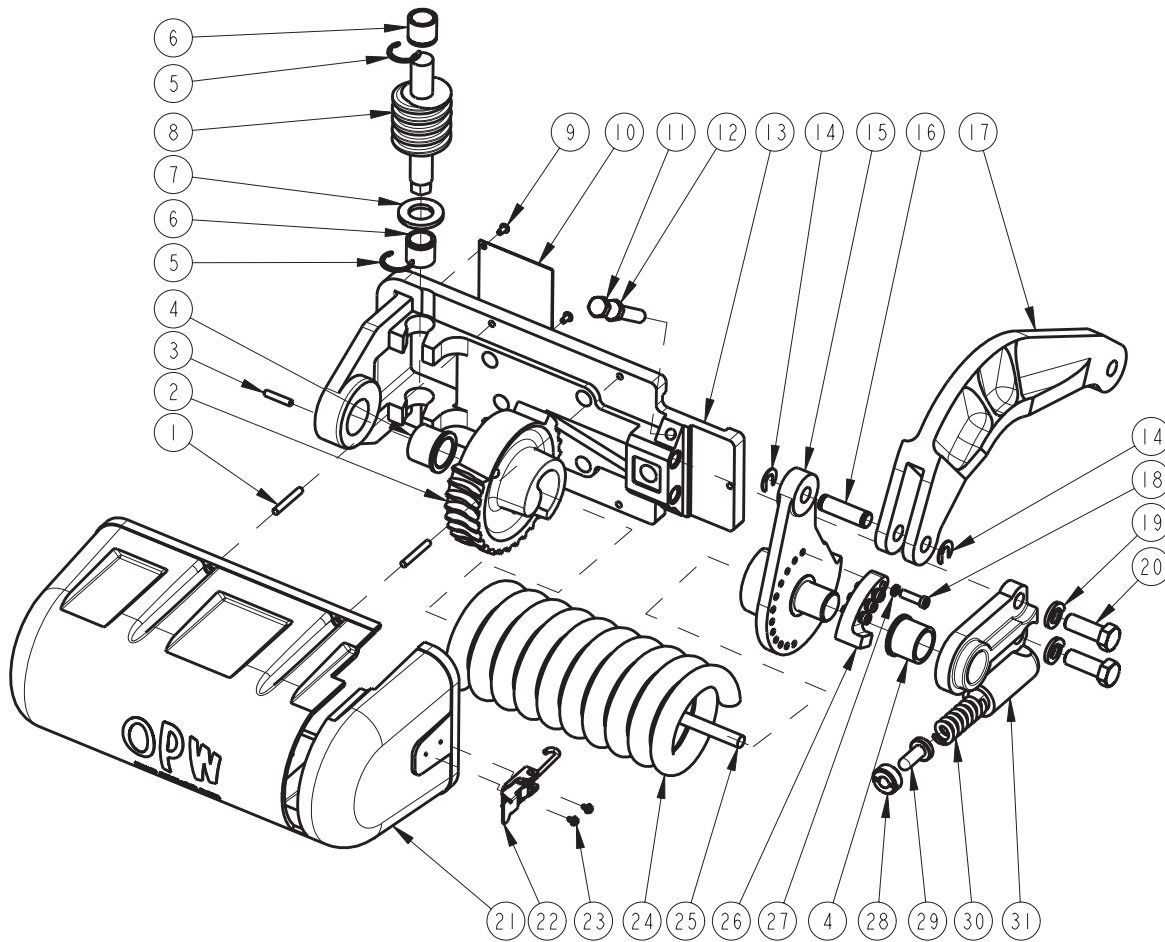

Index	Qty	Part #	Description	Index	Qty	Part #	Description
1	4	H-31396-M	Spirol Pin, 1/4 x 1 3/4	17	1	E-20041-D1	Link Arm, D1
2	1	C-20185-BW	Spring Regulator, R.H. Worm Gear	18	4	H-31278-M	Socket Head Screw, ZP, .31-18 X 1"
3	1	H-30744-M	Dowel Pin .25 x 1.25	19	2	H-02507-M	Lockwasher, CP, 5/8"
4	2	H-01490-M	Flange, Bearing, BRZ. 1 1/2" DIA x 1 1/4" LG	20	2	H-05910-M	Screw, Hex Cap, CST, ZP, 5/8"-11 x 1 3/4"
5	2	H-32283-M	Retaining Ring, CST ZP	21	1	E20116P	790 Spring Balance Cover, RH
6	2	H-32282-M	Bearing, Cylindrical, Bronze	22	2	H32321M	Spring Cover Latch (SouthCo)
7	1	H-30743-M	Washer, Thrust, ZP, 7/8"	23	4	H32322M	Screw, Thread Forming, 8-32
8	1	C-20184-EW	Drive Worm, Torsion Spring	24	1	C-00626-M	Spring, Torsion, C
9	2	H-30741-M	Screw, Drive #10 x 3/8"	25	1	H-30742-RS	Bar, Safety
10	1	H-30740-M	Worm Cover Plate, Spring Balance	26	1	H-01489-D1	Snubber Block, RH, D1
11	1	H-30018-M	Bolt, 1/2"-13 x 3 1/2	27	4	H-03563-M	Washer, Lock, ZP, 5/16"
12	1	H-30049-M	Jam Nut, Hex, CST, ZP, 1/2"-13	28	1	H-01486-RB	Snubber Retainer, Brass, 1 1/8"-12 x 1/2"
13	1	E20074D1	790 Support Bracket, D1	29	1	H-01487-RE	Snubber Plunger, SST, 1 5/16" DIA x 1 1/16" LG
14	2	H-30321-M	Retaining Ring, CST, 5/8"	30	1	H-01502-M	Spring, Compression, ZP
15	1	D-00350-D1	Spring Arm, PTD, D1	31	1	C00635D1	Support, RH Side, D1
16	1	H-30320-RE	Pin, Torsion Spring, SST				

Travel Stop 788, 789, 790 Series

Upward

Remove the (4) socket head screws in snubber block, then rotate snubber block toward pivot pin to allow for more upward travel or away from pivot pin for less upward travel. Replace the (4) screws and tighten.

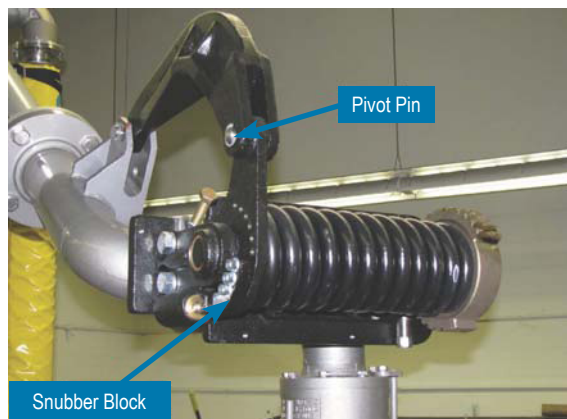

Downward

Loosen Jam Nut (located below lever arm) and turn stop bolt in for more downward travel or out for less downward travel. Then hold bolt and tighten jam nut securely.

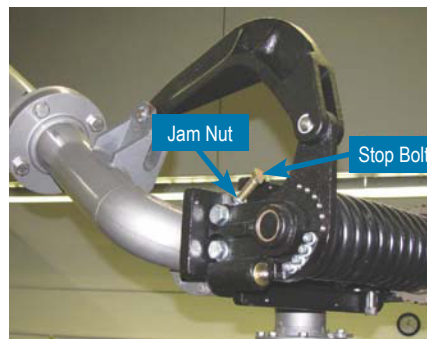

Adjustment 788, 789 Series

NOTE: Left hand spring balance shown.

NOTE: The worm gear adjustment mechanism provides significant mechanical advantage during adjustment. Under high load conditions (790) it is recommended that the loading arm be raised to approximately 45° above horizontal. Under low load conditions it is possible to adjust the spring torque without raising/supporting the loading arm.

**For more lifting action increase torque.
For less lifting action decrease torque.**

1. Raise loading arm to highest position and secure.
2. Hold Adjusting Nut of Spring Regulator [2] with a large wrench.
3. Loosen lower Bolt of Spring Keeper and remove upper one. Using a large screwdriver push Spring Keeper forward. With Spring Keeper disengaged turn Spring Regulator Adjusting Nut clockwise for more or counter clockwise for less torque.
4. With spring tension in desired position press Spring Keeper back into position on Spring Regulator. While holding Spring Regulator Adjusting Nut, tighten Spring Keeper Bolts [3]. Be sure Lock Washers [4] are in place.
5. Minor adjustment can be achieved by turning the Spring Keeper ½ position. This is done by removing the 2 Keeper Bolts [3] and turning the Spring Keeper end for end, so that the "teeth" of the Spring Keeper will be reversed.

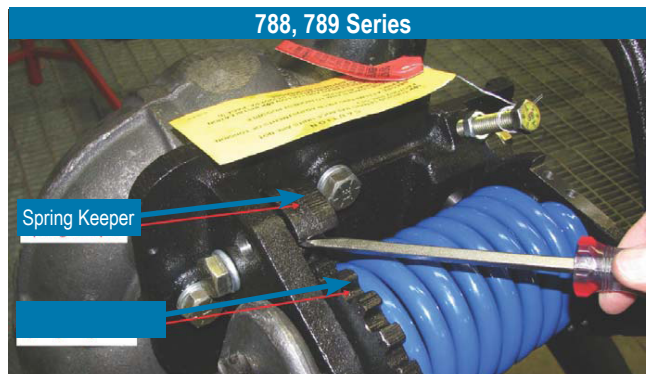

Parts List: 788, 789 Series Counterbalance

No.	Part	No.	Part
1	Torsion Spring	13	Snubber Block
2	Spring Regulator	14	Lock Washer
3	Bolt	15	Bolt
4	Lock Washer	16	Bolt
5	Spring Keeper	17	Nut
6	Spring Arm	18	Screw
7	Lever	19	Cover (NOT SHOWN)
8	E-ring	20	Spring Compression
9	Pin	21	Snubber Retainer
10	Support Bracket	22	Snubber Plunger
11	Bearing Flange	23	E-ring
12	Side Support	24	Pin

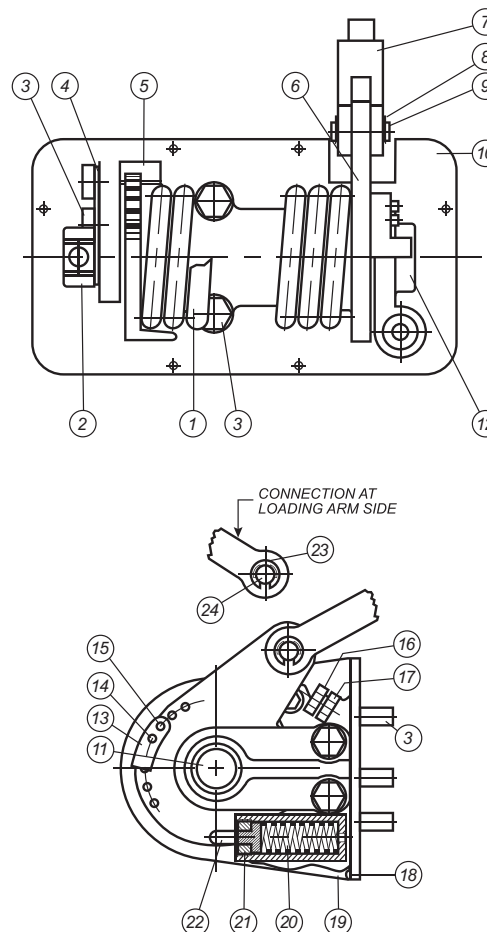

Maintenance 788, 789, 790 Series	
Lubrication	The torsion balance is provided with a self-lubricating Cylindrical Bearing. Only when operating under severe conditions, a little oil may be applied to Bearing [7]. Pins [13] on Spring Arm [23] and Link Arm [9] should have some oil quarterly.

Safety



Danger! Before performing any maintenance, always secure the Loading Arm and remove all tension from the counterbalance -- a torsion spring. The Loading Arm counterbalance spring contains a substantial amount of stored energy. You must relieve this energy before any disassembly. Failure to remove all tension from the counterbalance spring of the

Loading Arm before maintenance may cause serious personal injury or death.



WARNING! While installing and using the Loading Arm, always wear adequate personal protection, including hard hats, gloves, and steel-toed work boots. Failure to wear adequate personal protection may cause serious personal injury or death.



WARNING! Always follow the procedures prescribed in this Document. Failing to follow the procedures prescribed may damage the Loading Arm and cause serious personal injury or death. Consult Loading Arm Installation, Maintenance & Safety Manual for more details.