

## OPW Emergency Safety Disconnect

Safety Breakaway Coupling  
Type **NTS-PU Series (Pull-Away)**  
Sizes 1" - 4" (DN25 – DN100)

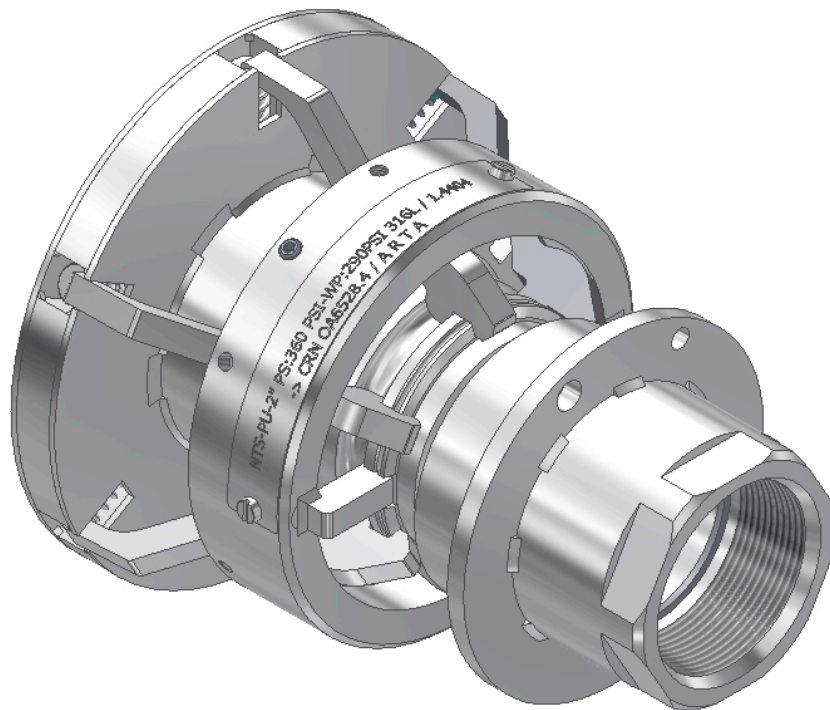

Content



Please read carefully the following OPW user manual to avoid incidents and in correct use.

	Page
<u><a href="#">Content .....</a></u>	<u><a href="#">2</a></u>
<u><a href="#">1.0 Description of the NTS-PU Safety Breakaway Coupling .....</a></u>	<u><a href="#">3</a></u>
<u><a href="#">2.0 Operator's manual NTS-PU .....</a></u>	<u><a href="#">5</a></u>
<u><a href="#">3.0 How to install the coupler .....</a></u>	<u><a href="#">6</a></u>
<u><a href="#">4.0 Testing of the coupler after a separation .....</a></u>	<u><a href="#">7</a></u>
<u><a href="#">5.0 Reassembly of the NTS-PU after a separation .....</a></u>	<u><a href="#">8</a></u>
<u><a href="#">6.0 Testing and Maintenance Recommendations .....</a></u>	<u><a href="#">13</a></u>
<u><a href="#">7.0 Remarks .....</a></u>	<u><a href="#">14</a></u>

## 1.0 Description Safety Breakaway Coupling

### 1.1 Area of use

The Safety Breakaway Coupling (NTS-PU) can be used in loading arms, hose- and pipelines for the transfer of fluids or gas. A typical application is the unintended tank truck/railcar/aircraft pull-off or the drifting away of a barge or ship.

### 1.2 Design

Both halves of this emergency coupling are equipped with non returning, spring loaded valves; they are held together by a fast coupling connection. Separation is triggered by a pulling force via the hose or loading arm. **The separation force is individually preset** for max. protection of the hose line.

### 1.3 Function

In the mounted status the NTS-PU is open and allows for free flow. If a tensile force exceeds the preset value the two halves separate. The valves instantly close on both ends to prevent spillage. The separation does not result in the destruction of parts (shear pins); **no spare parts** or special tools are required to instantly reassemble it after depressurizing and draining the hose line.

### 1.4 Advantages

- Working in any direction (angle)
- Built-in possible in both directions
- Easy reassembly after separation
- Mounting: tighten mounting screws, push 2 halves together and remove the mounting screws
- Cable-free activation
- Fully functional immediately after being built in; no further activation required
- Spare-part-free, non-destructive separation
- No shear pins involved and no destruction.
- Easily reassembled w/o tools or spare parts
- Ideal for LPG transfer lines

### 1.5 Materials

The following combinations are suggestions depending on the media:

	<b>Housing/internals</b>	<b>Seals</b>
<b>General chemical use:</b>	SS 316 (L / Ti)	Elastomer o-rings
<b>Acid- / alkaline solutions:</b>	Alloys	Elastomer o-rings
<b>Fuels / oils :</b>	SS 304 <b>Also available in anodized aluminum!</b>	Elastomer o-rings

Standard elastomer o-rings in FPM (FKM Viton®), EPDM, FFKM (Chemraz® / Kalrez®)  
Flat seals in PTFE (Teflon®)

*Other materials and seal rings upon request*

### 1.6 Specifications

<b>Sizes:</b>	1" - 4" (DN25 - DN100)
<b>Pressure rating:</b>	232psi (PN16) – Aluminium; 360psi (PN25) – SS
<b>Connections:</b>	BSP- and NPT- threads, DIN/ISO-, ASA-, TW- and TTMA-flanges <i>Other treads and flanges on request</i>

#### Separation force suggestions:

Size	1" (DN25)	2" (DN50)	3" (DN80)	4" (DN100)
WP - 90psi/6bar	660lbs (300kg)	2650lbs (1200kg)	3750lbs (1700kg)	4630lbs (2100kg)

### 1.7 Approvals

- CE-marked, Type-examination (Module B) according to Directive 97/23/EC
- ATEX, Manufactures Certificate of conformance according to Directive 94/9/EC (ATEX)
- Conform with clean air regulation (TA-Luft)
- Manufactured under DIN EN ISO 9001:2008

## 2.0 Operator's manual NTS-PU

### 2.1 Arrival condition of the NTS-PU



The NTS-PU is shipped with the reconnecting rods, nuts and bolts in place to prevent an inadvertent separation during the transport



These parts have to be removed before the NTS-PU goes into service as explained in the manual.

### 2.2 Removal of packing material

The NTS-PU is packed in special wrapping material and boxed for a safe transfer. All this material needs to be removed completely and disposed off correctly. Care must be taken to unpack and transport the coupler to its final destination without damaging it.

### 3.0 How to install the coupler

1. To assure a safe function the NTS-PU needs to be installed as follows:
  - a. Tensile force either axial or at an angle
  - b. The coupling halves need to have enough space to fully separate.

This guarantees the complete closure of the valves.

For all sizes 1" - 4" (DN25 – DN100) the minimal required distance between the two halves is 4" (100mm) at the point of separation.

2. The NTS-PU can be installed in any direction.
3. Installation should not lead to stress on the production line.



#### 4. Mounting screws must be removed before the use of the NTS-PU

5. During the separation small amounts of media could escape. We therefore recommend an additional spray protection.
6. The user manual (installation instructions) and the mounting screws should be kept in secure and accessible location.



**Caution!**  
**The Valves of the NTS-PU are spring loaded.**  
**Inappropriate disassembly could lead to injuries!**

#### 7. Warning !

During the loading or offloading process no person should be standing in the danger zone of the NTS. The separated hose end might pose an injury danger during the separation process. Emergency contingencies are to be followed according to local regulations and jurisdictions.

#### **4.0 Testing of the NTS-PU after a separation**

##### **4.1 Test procedure**

###### **a. Process environment**

Make sure the shut off valves on both sides to the NTS-PU are closed  
... that the line is depressurized  
... that the line is drained / purged

###### **b. Optical inspection**

Check for physical damage to the coupler  
Check seal rings for damage  
Check all release parts for damage  
Check face o-rings (where the two NTS-PU halves mate) for damage

##### **4.2 Evaluation of the damage and consequences**

###### **a. Minor damage**

Repair on site possible by local crew  
e.g. defective o-rings between the coupler halves or damaged seal ring  
Use only original spare parts

###### **b. More severe damage**

e.g. damage to the housing or to any of the moving parts  
Please contact the your OPW representative

## 5.0 Reassembly of the NTS-PU after a separation

### 1. Terminology of the most important coupler parts

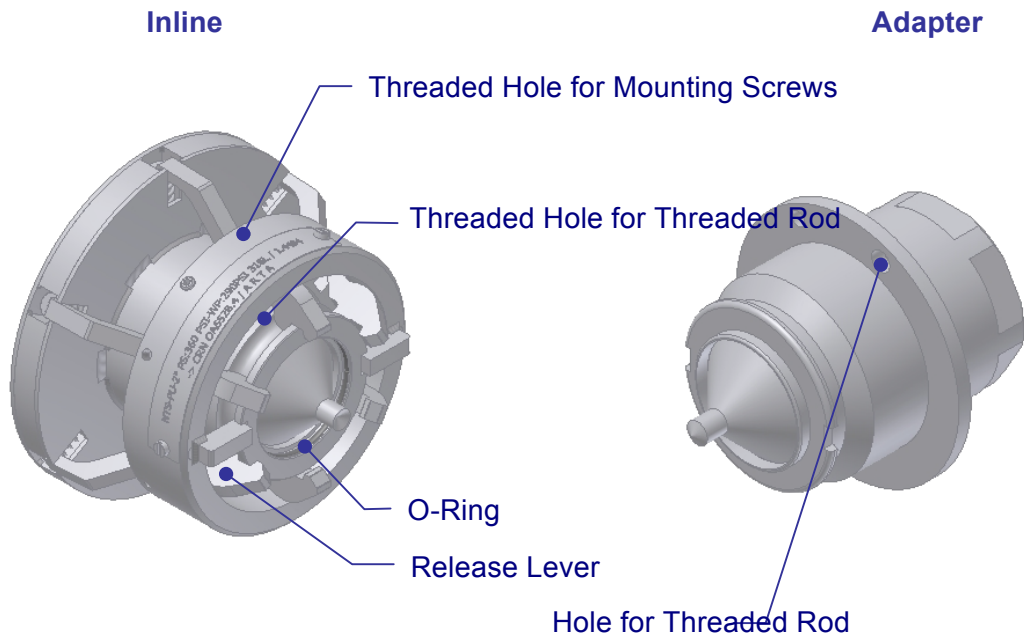





Depending on the size and the placement it might be easier to remove the coupler from the manifold in order to reassemble it.

2. Depressurize and empty line (page 7, point 4.1, line a)
3. Optical inspection (page 7, point 4.1, line b)
4. Place the 6 x Mounting Screws into the threaded hole at the Adapter  
The Release Levers open to allow reconnection

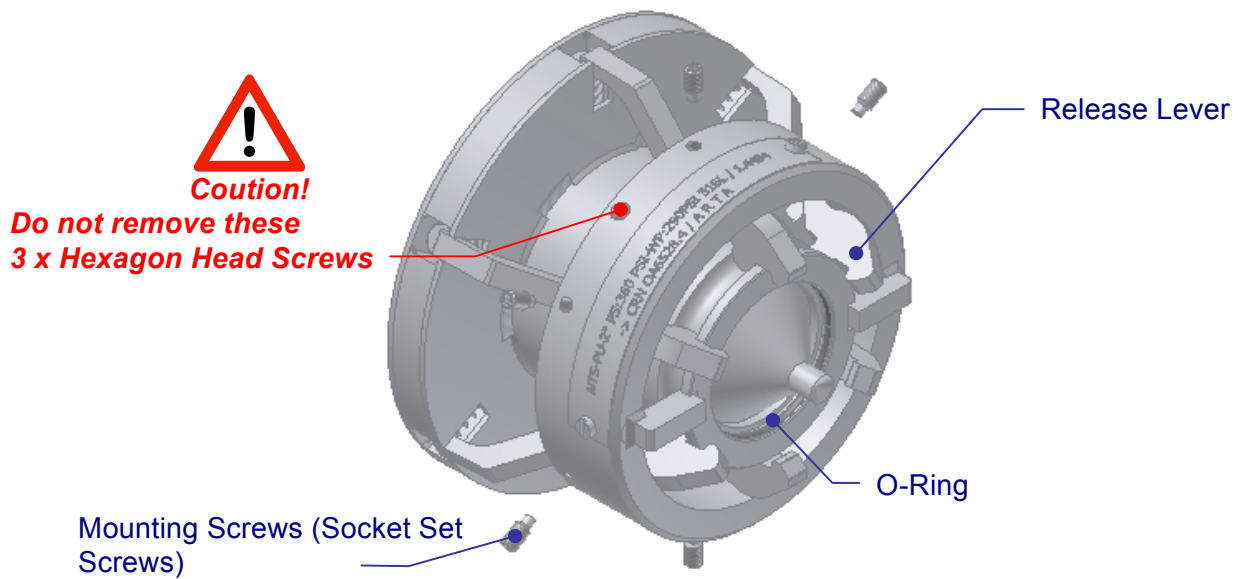

5. Place the 2 x threaded rods by turning them clockwise

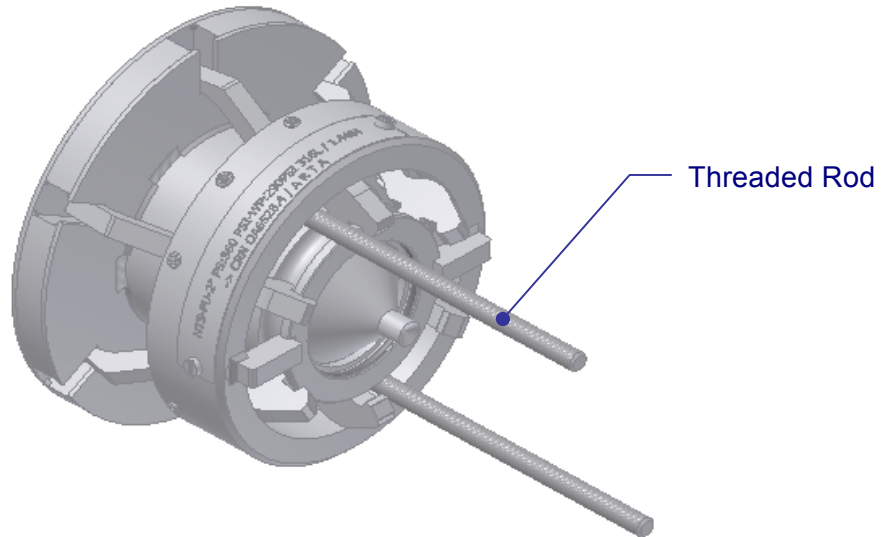

6. Place the Adapter on the top of the Inline and placing the 2 x washers and hex nuts of the threaded rods

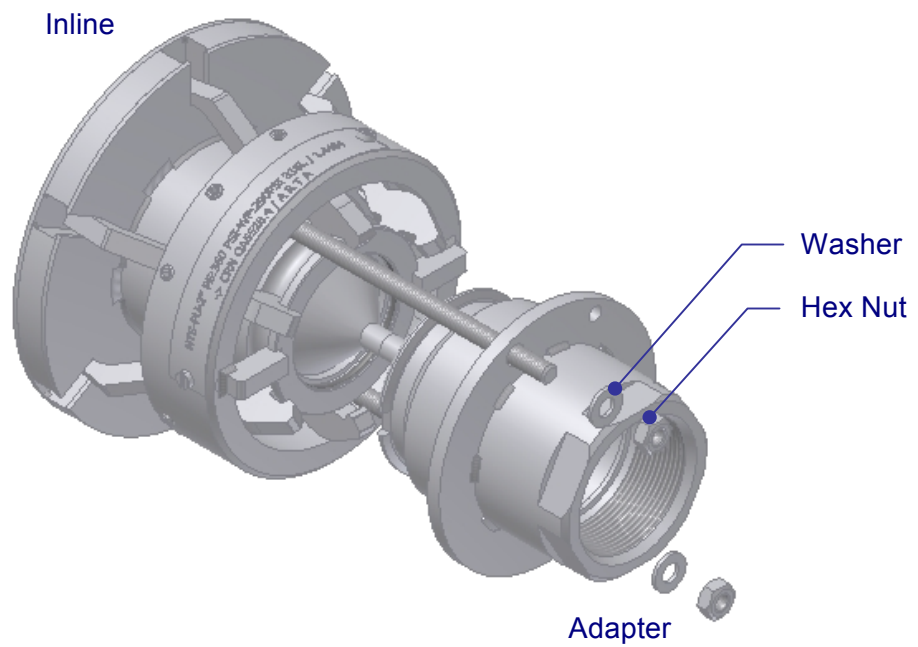

7. Narrow the space between adapter and inline initially by applying manual pressure, then by carefully tightening the hex head nuts crosswise as far as they go until the two halves are fully flush.

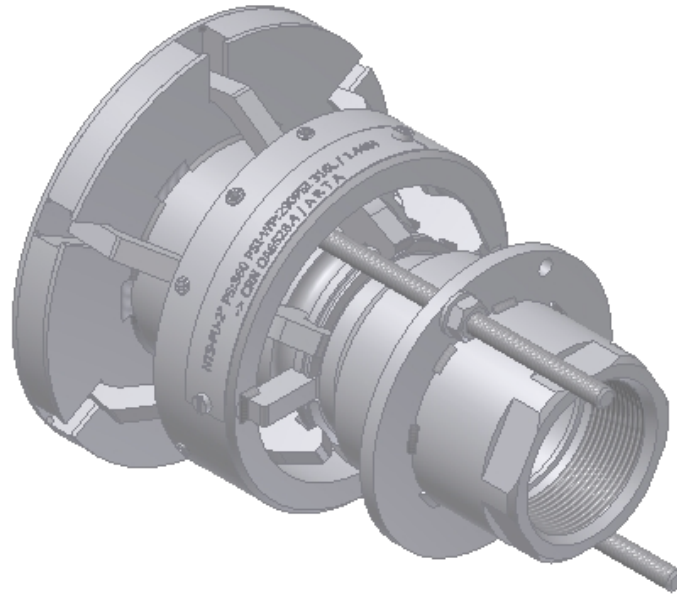

8. Replace the 6 x Mounting Screws out of the threaded hole at the Adapter body  
The Release Levers are closed and ready for use



**Caution!**

**Do not remove these  
3 x Hexagon Head Screws**

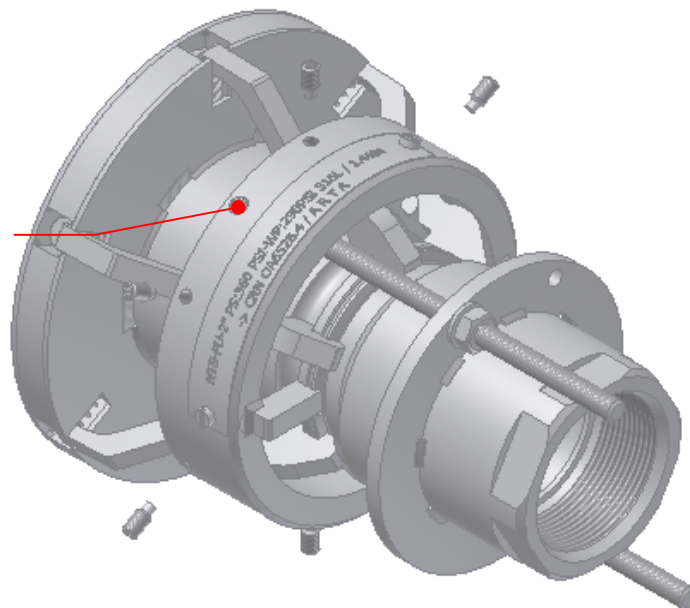

9. Remove the 2 x threaded rods including the washers and hex nuts

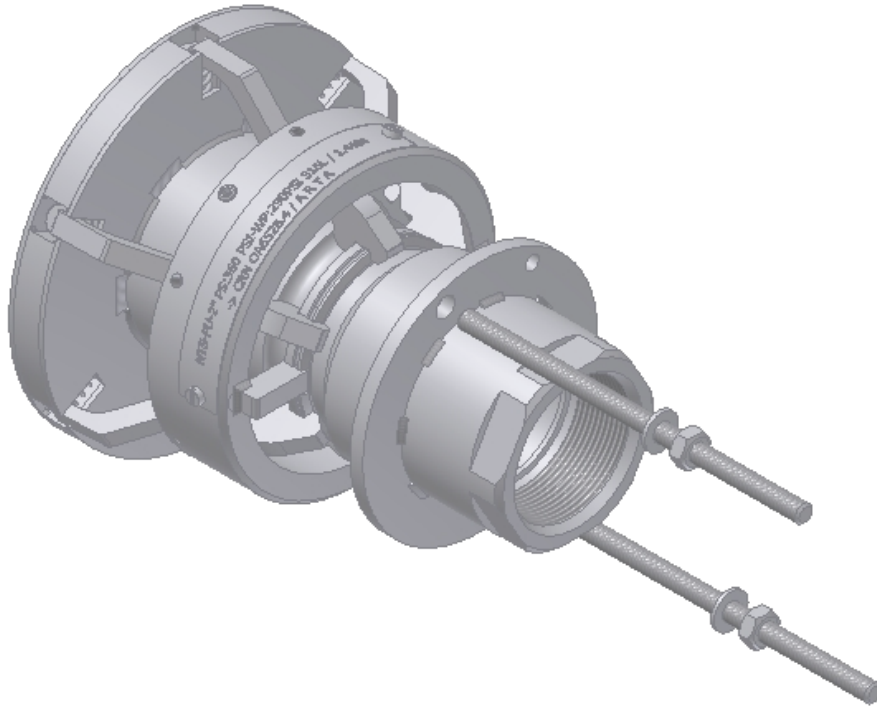

10. The Safety Breakaway Coupling is now complete and after the pressure test (page 13, point 3.4) ready for use

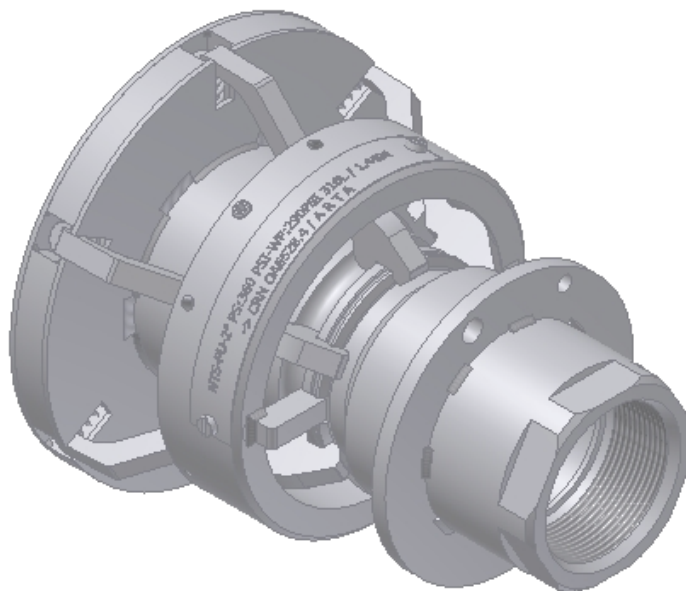

## **6.0 Test – and Maintenance recommendations – NTS-PU**

### **6.1 Test periods of the Safety Breakaway Coupler**

Independently from governmental regulations, we recommend to test Safety Breakaway Couplers at least once a year according to the test recommendations for thermoplastic, elastomer-type hoses.

A more vigorous use requires shorter test intervals. Elevated temperatures, higher concentrations, impurities and abrasive particles can significantly influence the corrosion resistance in Emergency Release Couplers.

### **6.2 Test procedure**

Test procedures are regulated by the local plant safety committee. It could involve for example pressure test of both coupler halves or the mounted coupler, a separation test and/or visual inspection.

The results need to be documented.

### **6.3 Pressure testing the coupling halves**

Test both halves individually (adaptor and inline) for leakage. Mount the threaded end (flange) of the separated half to the test unit and pressurize the system with fluid up to the required working pressure. Increase the pressure stepwise and check for leakage.

### **6.4 Pressure testing of the mounted NTS-PU**

Close the coupler on one side with a blind threaded end / blind flange and fill with fluid in an upright position. Apply the test connection and pressurize the system to the requested working pressure. Increase the pressure stepwise and check for leakage.

### **6.5 Separation testing**

Build in the NTS-PU in an axial fashion and trigger the separation with e.g. a cable winch. The use of a tensile force meter is recommended.

### **6.6 Maintenance**

The Emergency Release Couplers (breakaways) have minimal need for maintenance. All guiding elements, o-rings and seal rings should be periodically checked for porosity as well as for wear and tear.

Upon request, we can train the operating staff.

Spare parts for the Emergency Release Couplers (breakaways) can be ordered with the respective part number and product identification which can be found engraved onto the coupler.

### **6.7 Repairs**

Repairs to the Emergency Release Couplers (breakaways) can only be performed by trained and authorized personnel followed by subsequent testing, labeling and documentation. The spare parts available for many years.

### **6.8 Cleaning**

The NTS-PU needs to be thoroughly cleaned before any repair.

**7.0 Remarks**

Notes:

---

---

---

---

---

---

---

---

---

---

---

---

---

---

---

---

---

---

---

---

---

---

---

---

---