

Monitoring Well Sensors

Fuel

The Fuel Monitoring Well Sensor is used primarily in monitoring wells with fluctuating ground water tables. This sensor can also be placed in the containment areas of tanks, pumps and pipes. It will alert the system if any fuel enters the containment area, which would indicate a leak.

Part Number: 30-3207-06, 30-3207-10 and 30-3207-15
Dimensions: Diameter: 0.7" (1.8 cm)
Height: 6 to 15' (1.8 to 4.5 m)
Cables: 15' (4.5 m) of gas/oil-resistant cable
Operating Temp: -20° to 60°F (-4° to 122°C)

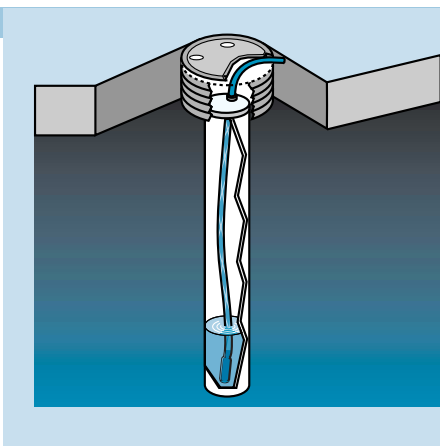

Fuel/Water

The Fuel/Water Monitoring Well Sensor contains all of the features mentioned above, as well as the ability to detect water. It will alert the system to the absence of ground water in a monitoring well or the presence of water in containment areas. This sensor has the ability to discriminate between hydrocarbon liquid and water. In the event there is a break in the cable, the system will activate the alarm.

Part Number: 30-3210-06, 30-3210-15 and 30-3210-20
Dimensions: Diameter: 0.7" (1.8 cm)
Height: 6 to 20' (1.8 to 6.0 m)
Cables: 15' (4.5 m) of gas/oil-resistant cable
Operating Temp: Fuel: -20° to 60°F (-4° to 122°C)
Water: 32° to 60°F (0° to 122°C)

Monitoring Well Sensors

Fuel Vapor

The Fuel Vapor Monitoring Well Sensor is designed to detect hydrocarbon vapors in monitoring wells and the interstitial areas of a double-wall tank. The presence of these vapors could indicate a potentially dangerous leak. After the vapors have dissipated, the sensor returns to normal and is ready to detect hydrocarbon vapors again. In the event that there is a break in the cable, the system will activate the alarm.

Part Number: 30-3222
Dimensions: Diameter: 0.9" (2.3 cm)
Length: 3.5" (8.9 cm)
Cables: 15' (4.5 m) of gas/oil-resistant cable
Operating Temp: -20° to 40°F (-4° to 104°C)

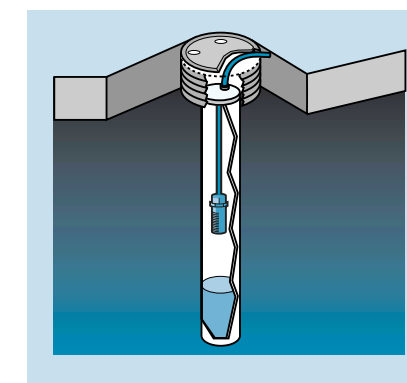

A DOVER COMPANY
ONE COMPANY. ONE WORLD. ONE SOURCE.

6900 SANTA FE DRIVE • HODGKINS, IL USA 60525 • www.opwfms.com • 708-485-4200 • (fax) 708-485-7137

NOTE: All information is subject to engineering and/or other changes. All trade names are copyrighted. Patents Pending. Form No. 60-8180 ©2002 OPW Fuel Management Systems
©2002 Delaware Capital Formation, Inc. All Rights Reserved. DOVER and the DOVER logo are registered trademarks of Delaware Capital Formation, Inc., a wholly-owned subsidiary of Dover Corporation.

SiteSentinel Sensors

Interstitial

Dispenser Pan/Sump

Monitoring Well



SiteSentinel Sensors

SiteSentinel sensors provide protection by monitoring the environment in and around the tank, interfacing directly to the SiteSentinel console through a single sensor interface that accommodates all sensor types and locations including: Tank Interstitial Spaces, Piping Sumps, STP Containment Sumps, Dispenser Sumps/Pans, and Monitoring Wells.

Sensor selection is determined by installation location and detection capability. The SiteSentinel sensors, which detect the presence of water or fuel in contained areas, provide an alarm indicating only the presence of a liquid. Some of the SiteSentinel sensors that detect the presence of liquid in contained areas will provide alarms which indicate if the fluid detected is water or fuel.

Interstitial Sensors

Liquid Only

The Liquid Only Interstitial Sensor is used primarily in the interstitial area of double-wall tanks. The sensor contains a float switch that activates in the presence of liquid. This sensor is available in two configurations: the 30-3221-1A is constructed from a chemically resistive non-metallic material, and the 30-3221-1B is constructed of brass. This sensor can also be used in sumps, dispenser pans and other locations where the presence of a liquid could indicate that a leak has occurred. In the event of a break in the cable, the system will activate an alarm.

Part Number: 30-3221-1A and 30-3221-1B
Dimensions: 30-3221-1A
Diameter: 1.3" (3.4 cm)
Length: 3.9" (10 cm)
30-3221-1B
Diameter: 1.4" (3.5 cm)
Length: 3.5" (9 cm)
Cable: 15' (4.5 m) of gas/oil-resistant cable.
Operating Temp: -20° to 60°F (4° to 122°C)

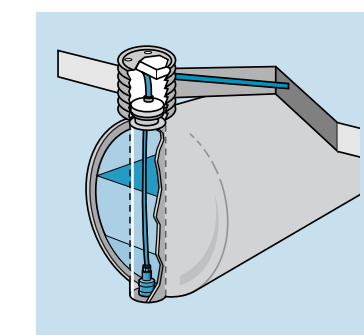

Interstitial Sensors

Fuel/Water

The Fuel/Water Interstitial Sensor is designed for use in the interstitial area of a double-wall tank. This sensor is easily installed to discriminate between fuel and water. The system will also activate an alarm in the event of a break in the cable.

Part Number: 30-3206
Dimensions: Diameter: 1.0" (2.5 cm)
Length: 13.8" (35 cm)
Cables: 20' (6.0 m) of gas/oil-resistant cable
Operating Temp: Fuel: -20° to 60°F (-4° to 122°C)
Water: 32° to 60°F (0° to 122°C)

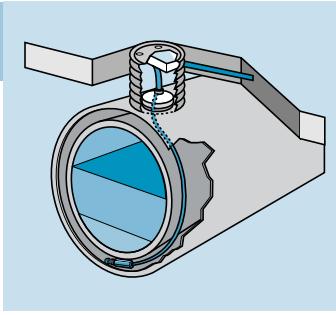

Dual Level Hydrostatic

The Dual Level Hydrostatic Interstitial Sensor is designed for use in the brine-filled reservoir of the interstitial area of a double-wall tank. This sensor contains a dual level float switch that detects level changes of fluid in the reservoir of the tank. The alarm will also activate in the event of a break in the cable.

Part Number: 30-3221-2
Dimensions: Diameter: 2.4" (6 cm)
Length: 14" (35.6 cm)
Cables: 15' (4.5 m) of gas/oil-resistant cable
Operating Temp: -20° to 60°F (-4° to 122°C)

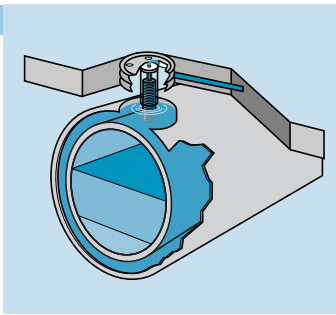

Liquid Only

The Liquid Only Interstitial Sensor is used primarily to monitor the interstitial area of double-wall tanks. This sensor can also be used in sumps, dispenser pans and other locations where the presence of a liquid could indicate that a leak has occurred. If there is a break in the cable, the alarm will be activated by the system.

Part Number: 30-3223
Dimensions: Diameter: 0.7" (1.8 cm)
Length: 2.8" (7 cm)
Cables: 20' (6.0 m) of gas/oil-resistant cable
Operating Temp: -20° to 60°F (-4° to 122°C)

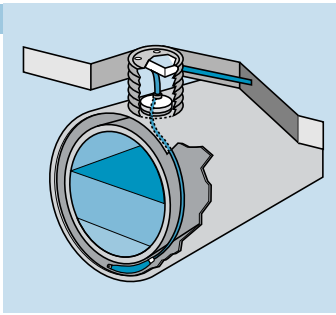

Dispenser Pan/Sump Sensors

Combination Single Level Fuel/Water

The Combination Single Level Fuel/Water Sump Sensor is designed to detect the presence of liquid hydrocarbons and water in sumps, dispenser pans and other locations where the presence of a liquid could indicate that a leak has occurred. Liquid hydrocarbons are detected with the fuel sensor. A simple float switch is clamped onto the fuel sensor which can be positioned at any height to activate in the presence of a liquid. The alarm will also be activated in the event of a break in the cable.

Part Number: 30-3224
Dimensions: Fuel Sensor: Diameter: 1.7" (4.4 cm)
Length: 13.2" (33.5 cm)
Single Level Float Switch Sensor: Diameter: 1.3" (3.4 cm)
Length: 3.9" (10 cm)
Cables: 15' (4.5 m) of gas/oil-resistant cable
Operating Temp: -20° to 60°F (-4° to 122°C)

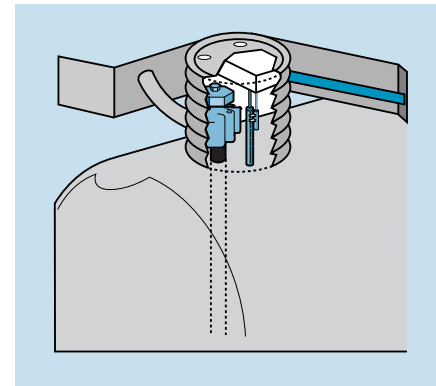

Combination Dual Level Fuel/Water

The Combination Dual Level Fuel/Water Sump Sensor is designed to detect the presence of liquid hydrocarbons and water in sumps, dispenser pans and other locations where the presence of a liquid could indicate that a leak has occurred. The fuel sensor detects the presence of liquid hydrocarbons. A dual float switch simply clamps onto the fuel sensor and activates in the presence of liquid to provide low-level and high-level alarms. The alarm will also be activated in the event of a break in the cable.

Part Number: 30-3225
Dimensions: Fuel Sensor: Diameter: 1.7" (4.4 cm)
Length: 13.2" (33.5 cm)
Dual Level Float Switch Sensor: Diameter: 2.9" (6 cm)
Length: 14" (35.6 cm)
Cables: 15' (4.5 m) of gas/oil-resistant cable
Operating Temp: -20° to 60°F (-4° to 122°C)

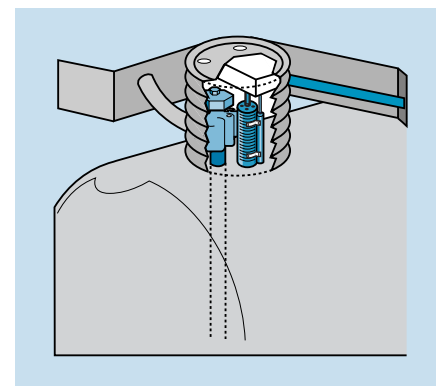

Dispenser Pan/Sump Sensors

Single Level

The Single Level Sump Sensor is designed to detect the presence of liquid in sumps, dispenser pans and other locations where the presence of a liquid could indicate that a leak has occurred. If there is a break in the cable, the alarm will be activated by the system.

Part Number: 30-3221-1
Dimensions: Diameter: 2.9" (7.4 cm)
Length: 3.7" (9.5 cm)
Cables: 15' (4.5 m) of gas/oil-resistant cable
Operating Temp: -20° to 60°F (-4° to 122°C)

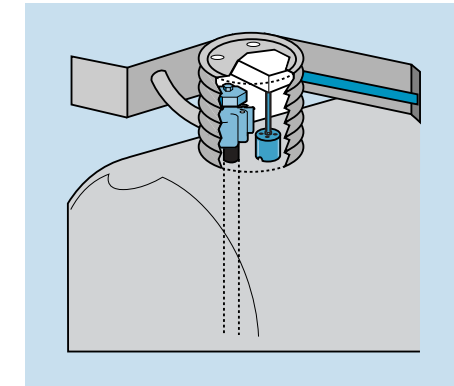

Fuel

The Fuel Sump Sensor is designed to detect the presence of liquid hydrocarbons in sumps, dispenser pans and other locations where the presence of a hydrocarbon liquid could indicate that a leak has occurred. In the event of a cable break, the system will activate the alarm.

Part Number: 30-3219-12
Dimensions: Diameter: 1.7" (4.4 cm)
Length: 13.2" (33.5 cm)
Cables: 15' (4.5 m) of gas/oil-resistant cable
Operating Temp: -20° to 60°F (-4° to 122°C)

