

Model A-212-FR20

Vacuum Relief Valve

August 17, 2015

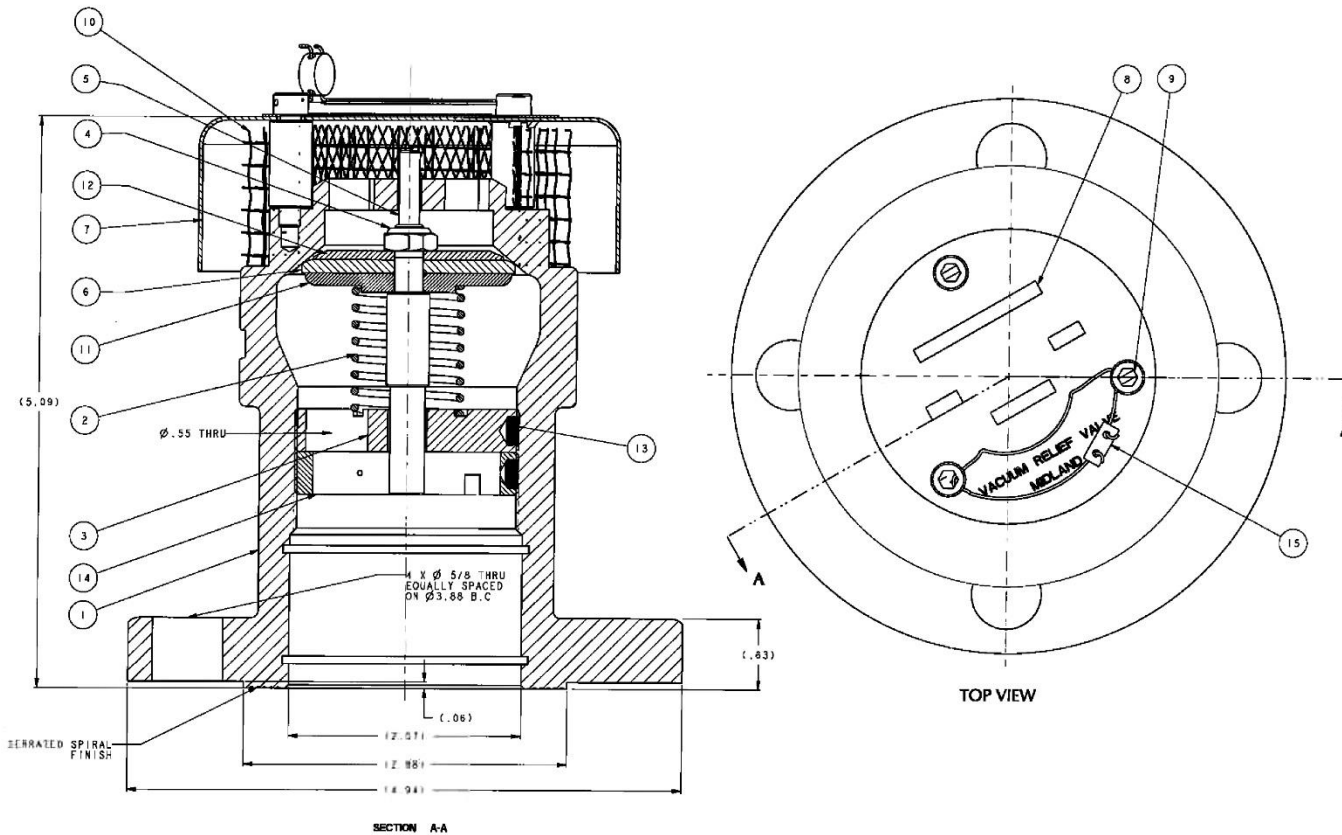

Item	QTY	Part Name	Material	Part No.
1	1	BODY	STAINLESS	212-010-SS
2	1	SPRING	STAINLESS	SEE TABLE
3	1	ADJUSTMENT NUT	STAINLESS	210-03-SS
4	1	LOCKNUT	STAINLESS	210-04-SS
5	1	STEM	STAINLESS	210-05-SS
6	1	SEAL	BUNA N (*)	210-06-BN
7	1	WEATHER CAP ASM	STAINLESS	210-07-SS
8	1	NAMEPLATE	STAINLESS	210-08-SS
9	3	CAP SCREW	STAINLESS	210-09-SS
10	1	FILTER	STAINLESS (*)	210-101-SS
11	1	WASHER	STAINLESS	210-11-SS
12	1	RETAINER	STAINLESS	210-12-SS
13	4	INSERT	PTFE	210-13-TF
14	1	LOCKING RING	STAINLESS	210-140-SS
15	1	SEAL WIRE	STAINLESS/LEAD	22-72-PB

MODEL #	VACUUM SETTING	SPRING PART #
A-212-FR20	0.75	207-2-MO
A-212-FR20-2	2	210-2-MO
A-212-FR20-3	3	207-21-MO
A-212-FR20-4	4	212-2-MO
A-212-FR20-5	5	212-2-MO

NOTES:

- (*) ALTERNATE MATERIAL CONFIGURATIONS AVAILABLE
- STANDARD MINIMUM START TO DISCHARGE PRESSURE SETTING IS 0.75 PSI VACUUM. ALTERNATE START TO DISCHARGE PRESSURE SETTINGS ARE AVAILABLE
- AAR APPROVAL # E112007