

Model A-1402-C Series

Pressure Relief Valve

Valve Model No.	Rupture Disk Setting (PSIG)	Flow Rate @ 10% > R.D. Setting (PSIG)	Valve Pressure Setting (PSIG)	Vapor Tight Pressure (Minimum) (PSIG)	Outer Spring	Inner Spring	Nameplate	Adjusting Screw Part #	Rupture Disc Part #
A-14377C-ML	375	7070	351	336	15-375-SS	14-13-SS	14-377-ML-C	15-112-SS	14-23-TA-375-F
A-14227C-ML	225	4367	210	200	15-150-MO	14-13-SS	14-227-ML-C	15-11-SS	14-23-TA-225-F

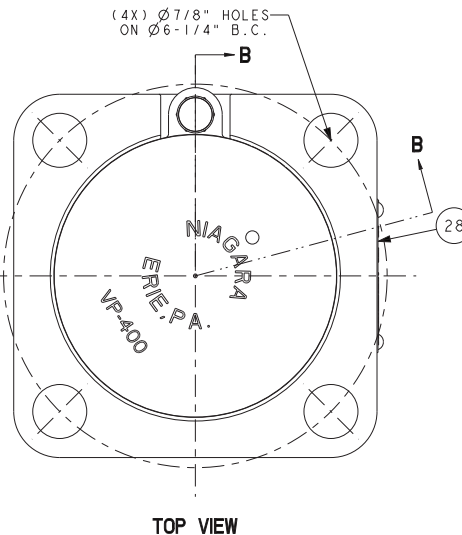
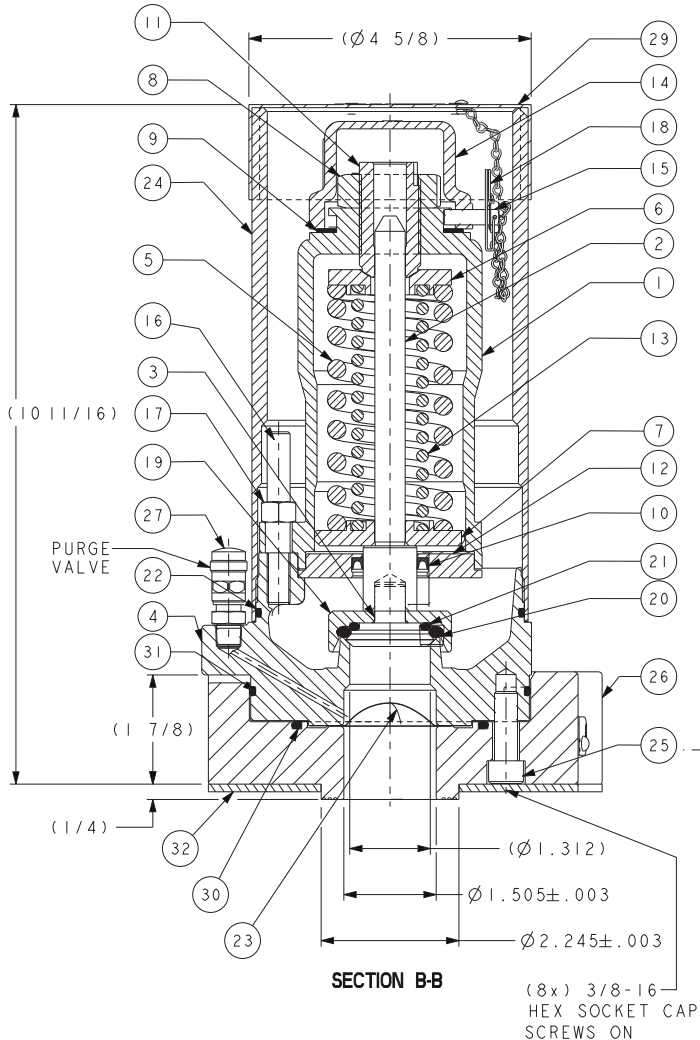

Item	Qty	Part Name	Hastelloy C Trim	
			Material	Part No.
1	1	Top Guide	Stainless Steel	14-101-SS
2	1	Stem	Hastelloy C/Monel	14-2-XC
3	1	Plug	Hastelloy C	14-3-HC
4	1	Body	Hastelloy C	14-4810-HC
5	1	Outer Spring	Stainless Steel	15-375-SS
6	1	Follower	Stainless Steel	14-6-SS
7	1	Guide	Stainless Steel	14-7-SS
8	1	Top Nut	Stainless Steel	15-8-SS
9	1	Top Gasket	Viton	15-9-VA
10	1	Shaft Seal	PTFE	17-10-TF
11	1	Adjusting Screw	Stainless Steel	15-111-SS
12	1	Seal Retainer	Monel	14-12-ML
13	1	Inner Spring	Stainless Steel	14-13-SS
14	1	Cap	Stainless Steel	14-14-SS
15	1	Seal Screw	Steel Plated	15-15-CS
16	4	Stud	Monel	14-16-ML
17	4	Nut	Monel	14-17-ML
18	1	Wire Seal	SS Wire, Lead Seal	22-72-PB
19	1	Retainer	Hastelloy C	14-19-HC
20	1	Seat "O" Ring	Viton	10-10-VL
21	1	Plug "O" Ring	Viton	10-11-VL
22	1	Flue "O" Ring	Viton	14-22-VA
23	1	Rupture Disc	Tantalum	14-23-TA-375-F
24	1	Flue (1)	Plastic(1)	14-24-PC
25	8	Rupture Disc Flange Bolts	Monel	15-163-ML
26	1	Rupture Disc Flange	Monel	14-380-ML
27	1	Purge Valve	Monel	17-240-ML
28	1	Nameplate	Monel	14-377-ML-C
29	1	Protective Cap/Chain	Polyethylene/SS	14-311-PE
30	1	Flange O-Ring Inner	Viton	14-332-VL
31	1	Flange O-Ring Outer	Polyethylene/SS	14-331-VL
32	1	Filler Gasket	Viton	14-30-VA

NOTES:

1. FOR STAINLESS STEEL FLUE, ADD SUFFIX -S TO MODEL NUMBER.

Revision Date: December 10, 2020