

A-215-W-NS to A-217-W-NS (NO STEP)

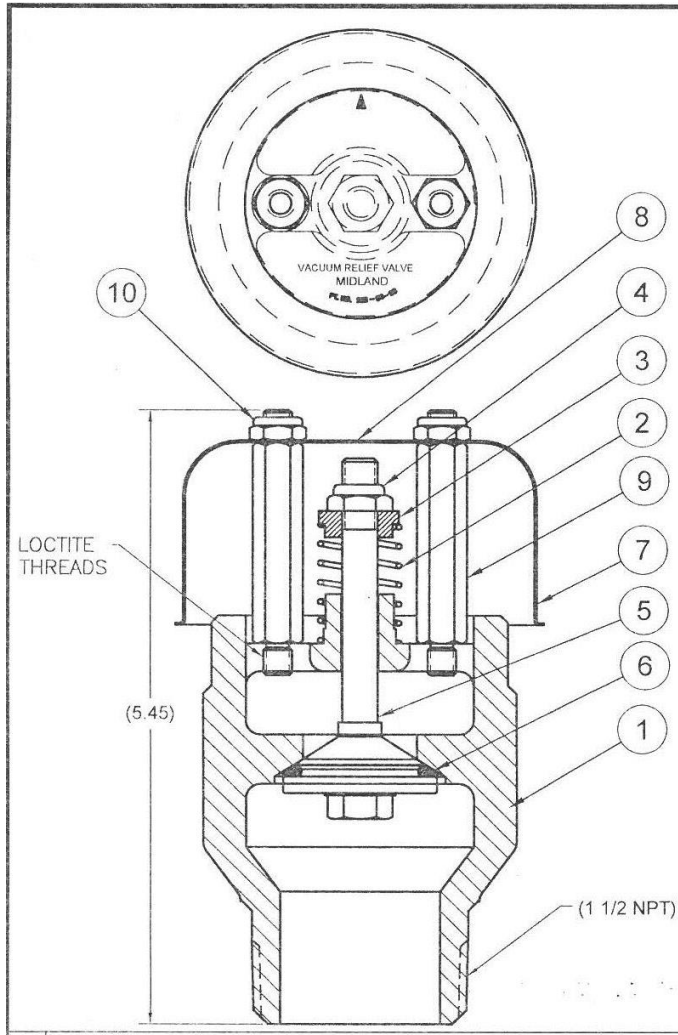

ITEM NO.	QTY.	PART NAME	A-215-W-NS		A-217-W-NS		A-217-W-NS-PRA	
			MATERIAL	PART NO.	MATERIAL	PART NO.	MATERIAL	PART NO.
1	1	BODY	STEEL	215-100-CS	STAINLESS	217-100-MO	STAINLESS (2)	217-100-MO-PRA
2	1	SPRING	STAINLESS	SEE TABLE	STAINLESS	SEE TABLE	STAINLESS	SEE TABLE
3	1	SPRING SEAT	STAINLESS	217-3-SS	STAINLESS	217-3-SS	STAINLESS	217-3-SS
4	1	LOCK NUT	STEEL	217-41-CS	STAINLESS	217-41-SS	STAINLESS	217-41-SS
5	1	STEM	STAINLESS	217-50-MO	STAINLESS	217-50-MO	STAINLESS (2)	217-50-MO-PRA
6	1	PRESSURE SEAL	BUNA N (1)	215-6-BN	BUNA N (1)	215-6-BN	BUNA N (1)	215-6-BN
7	1	WEATHER CAP	STAINLESS	215-70-SS	STAINLESS	215-70-SS	STAINLESS	215-70-SS
8	1	NAMEPLATE	STAINLESS	217-84-SS	STAINLESS	217-84-SS	STAINLESS	217-84-SS
9	2	POST	STAINLESS	217-90-SS	STAINLESS	217-90-SS	STAINLESS	217-90-SS
10	2	LOCKNUT	STAINLESS	720-181-SS	STAINLESS	720-181-SS	STAINLESS	720-181-SS

NOTES:

1. ALTERNATE MATERIAL AVAILABLE.
2. PARTS TO BE CERTIFIED TO ASTM A262 PRACTICE A.

VACUUM SETTINGS ARE SHOWN IN TABLE.

VACUUM SETTING (PSI)	SPRING PART NUMBER
.75	215-2-MO
3	215-27-MO
4	215-23-MO
5-8	215-24-MO
10	215-25-MO

NET FLOW AREA .71 SQ. IN.

AAR APPROVAL #E102003